

NOTE: THIS DRAFT INCORPORATES ALL SUBSTANTIVE CHANGES PROPOSED BY THE COMMUNITY DEVELOPMENT DEPARTMENT, THE DEPARTMENT OF PUBLIC WORKS AND THE DEPARTMENT OF PARKS, RECREATION AND OPEN SPACE. THIS DRAFT ALSO INCLUDES SOME CLERICAL CHANGES, BUT NUMEROUS ADDITIONAL CLERICAL CHANGES ARE IN PROGRESS. EVERY DIVISION AND EVERY SECTION OF THIS TITLE 18 APPENDIX, UNLESS REPEALED, WILL BE FURTHER REFINED WITH CLERICAL REVISIONS FOR GRAMMATICAL CORRECTIONS, SUBSTANTIVE CLARITY AND CONSISTENCY IN STYLE.

SECTION XXXX:

That Title 18 Appendix (CARSON CITY DEVELOPMENT STANDARDS), Division 1 (LAND USE AND SITE DESIGN), Section 1.0 (General) is hereby amended (**bold, underlined** text is added, [~~stricken~~] text is deleted) as follows:

1.0 [General.

~~These design standards have been prepared to foster quality design of office, commercial, multi-family, public, industrial and institutional projects within Carson City. The] **General purpose; declaration of intent.**~~

It is hereby declared that the image of the community affects the economic [~~well-being~~] **well-being** of the [city, especially the tourism economy.] **City.** These standards are [~~aimed at improving the community image.~~

~~These standards] **hereby established in this Title 18 Appendix to improve the image of the community by fostering quality design of projects within the City and** are intended to inspire **the** development of lasting quality and designs that enhance the overall [~~community.~~ They] **community for the benefit of the residents, businesses and visitors of the City. These standards** are **further** intended to assist the public, developers and design professionals in planning and designing [~~projects. These standards shall also] **projects and** serve as criteria for design review by [city] **City** staff, the [~~planning commission (commission), and board of supervisors (board).] **Commission and the Board of Supervisors.**~~~~~~

SECTION XXXX:

That Title 18 Appendix (CARSON CITY DEVELOPMENT STANDARDS), Division 1 (LAND USE AND SITE DESIGN), Section 1.1 (Architectural design) is hereby amended (**bold, underlined** text is added, [~~stricken~~] text is deleted) as follows:

1.1 Architectural design.

[~~Office, retail, commercial, public, institutional, industrial and multi-family buildings and their architecture] **The architectural design standards set forth in this section apply to**~~

development, other than single-family residential development, located within all zoning districts. Architectural design standards play a large role in establishing the overall image of the community. In all cases, these standards [~~stress~~] **emphasize** the importance of visually identifying and unifying the community character. These standards do not require a single architectural [~~style; instead~~] **and** an eclectic mixture of harmonious styles are encouraged. Buildings [~~which are 50 years or older within the downtown area must meet the requirements of the downtown business district found in the Carson City Municipal Code-~~] **that are located in the Downtown Mixed-Use (DT-MU) district must comply with the specific design standards of that zoning district in addition to the applicable standards set forth in this Title 18 Appendix.**

- 1.1.1 The architectural style, massing and proportion of a building should be compatible with and [~~complement~~] **complement** its surroundings and environmental characteristics of the community.
- 1.1.2 Buildings should be designed on a "human scale" by using architectural enhancements such as windows, awnings, arcades, plazas, courtyards and roof overhangs.



Architectural enhancements such as roof overhangs, arcades and trellises [~~shall~~] must be used.

- 1.1.3 Variations of building details, form, line, color and materials [~~shall~~] **must** be employed to create visual interest. Variations in wall planes, roof lines and direction are encouraged to prevent monotonous appearance in buildings. Large expanses of walls devoid of any articulation or embellishment [~~shall~~] **must** be avoided.

[Similarly vertical] **Vertical** variation in the roof line is encouraged. [~~Mansard roofs shall wrap around the entire building.~~]

DRAFT

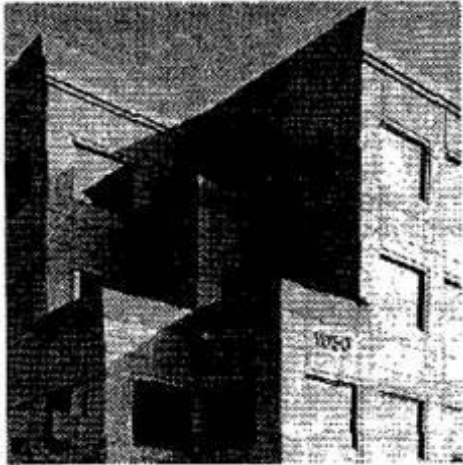

Variation in wall planes adds interest

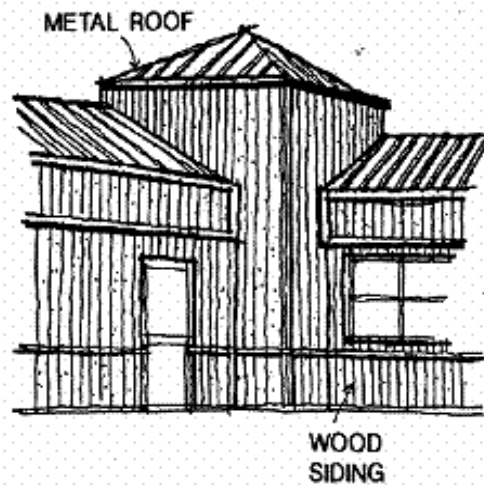
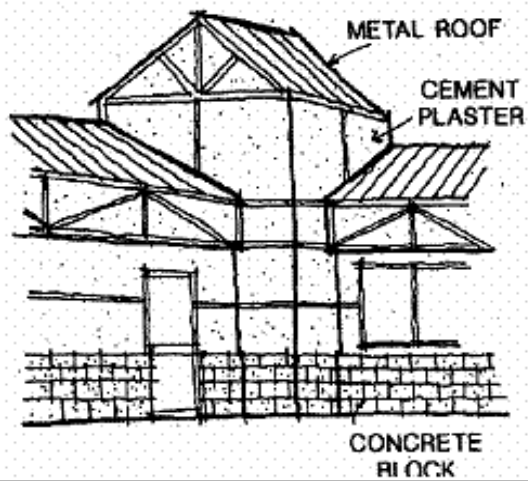
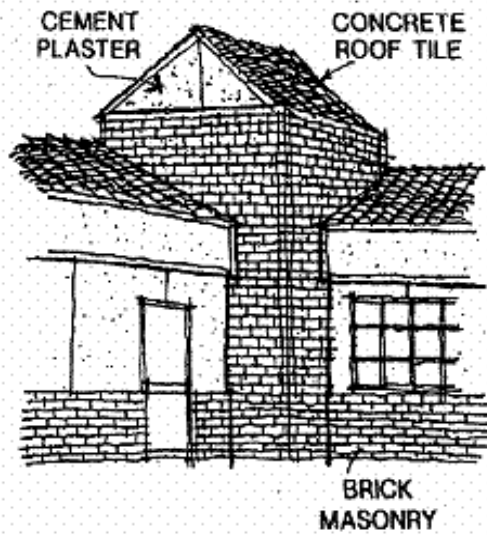
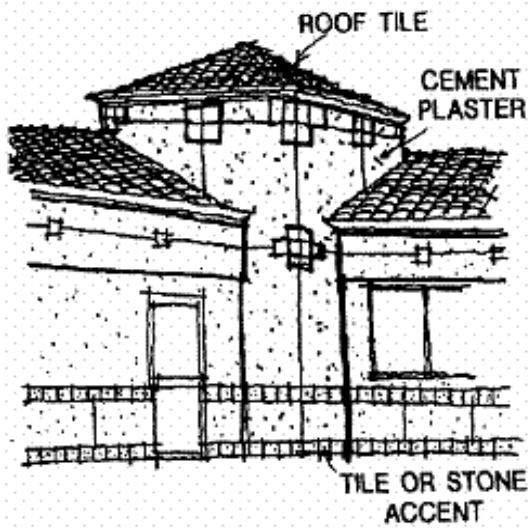

Typical materials and finishes

1.1.4 All building elevations ~~[shall]~~ **must** receive architectural treatment, except in special ~~[situations]~~ **circumstances** where an elevation is not visible from an adjoining property or street.

1.1.5 Materials and finishes ~~[shall]~~ **must** be selected for architectural harmony and enhancement of the architectural theme, as well as aesthetic quality, durability and ease of maintenance. Materials, finishes and colors ~~[shall]~~ **must** be varied where appropriate to provide architectural interest. The number of building materials **must** generally ~~[shall]~~ be limited to three and these materials ~~[shall]~~ **must** not stop abruptly at ~~[corners, but]~~ **corners and instead** continue to side or back elevations. ~~[Smooth faced block or fabricated metal wall panels are not allowed as the predominant building material.]~~

~~1.1.6 Exterior building colors should blend with surrounding development and not cause abrupt changes. Primary building surfaces (excluding trim areas) should be muted or earthtone in color. Bold colors shall be avoided except when used as accent or trim.~~

~~1.1.7~~ **1.1.6.** Except as otherwise provided in this section, roof-mounted equipment ~~[within commercial, industrial, office, public or multi-family districts shall]~~ **must** be screened from view from a public right-of-way and adjacent property ~~[through the use of]~~ **by using** architectural means such as parapet walls and equipment wells. Screening of roof-mounted equipment from view must be integrated into the building design. All equipment ~~[shall]~~ **must** be located below the highest vertical element of the building. Wall-mounted air conditioning units ~~[shall]~~ be integrated into the design ~~[and/or]~~ **or** screened. ~~[Roof-mounted solar panels are excluded from the requirement for screening.]~~ Roof-mounted mechanical support and accessory mechanical equipment for solar panels ~~[shall]~~ **must** be screened architecturally and integrated to match the existing roof ~~[and/or]~~ **or** building materials. **This section does not apply to roof-mounted solar panels.**

On ~~[sites exhibiting]~~ **any site that exhibits** topographic relief ~~[effecting]~~ **which affects** visual screening capabilities, site-obscuring screening ~~[shall]~~ **must** be provided to visually screen the equipment at a minimum of 100 feet from the site.

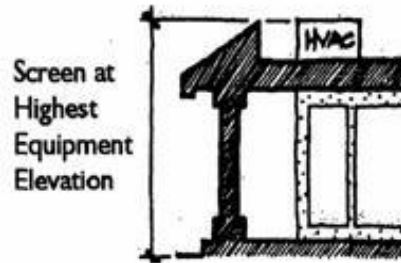
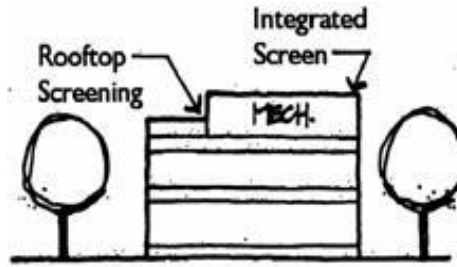

Typical Equipment Screening

[1.1.8] **1.1.7.** Reflective, untreated roofs ~~[shall be prohibited unless painted flat, non-glossy paint to compliment or match the primary color of the primary exterior building material(s)].~~

1.1.9] **are prohibited.**

1.1.8. ~~[Multi-building/tenant projects shall include]~~ **A multi-building or tenant project must exhibit architectural consistency for all buildings, including, without limitation, consistency in** color schemes, wall textures, roofs, roof slopes, awnings and other similar architectural themes.

[1.1.10 Buildings which give] **1.1.9 Any building that exhibits** the appearance of "box-like" structures ~~[shall be]~~ **is** discouraged.

SECTION XXXX:

That Title 18 Appendix (CARSON CITY DEVELOPMENT STANDARDS), Division 1 (LAND USE AND SITE DESIGN), Section 1.2 (Site design) is hereby amended (**bold, underlined** text is added, ~~[stricken]~~ text is deleted) as follows:

1.2 Site design.

The site design standards set forth in this section apply to development, other than single-family residential development, located within all zoning districts. These standards are intended to promote quality development, visual compatibility, safety and consistency through an integration of site design elements, including, **without limitation,** building orientation and location, site access, circulation, parking, service areas and pedestrian and bicycle access. ~~[Of primary concern is]~~ **It is hereby declared that the appearance of a development as viewed from the [street.] street constitutes a primary concern of these standards.**

- 1.2.1 [Primary entries and/or facades of buildings] **The primary entry or facade of a building** should be oriented towards the street or main parking area.

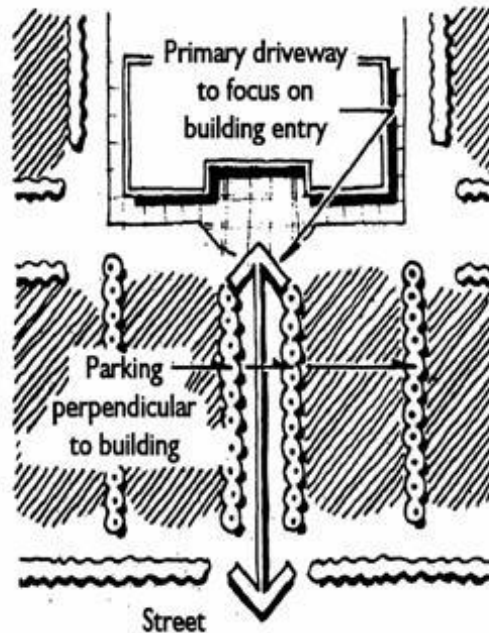

Typical building and parking relationship

- 1.2.2 The orientation and location of a building should provide for pedestrian and bicycle activity and access. [Bike racks shall] **If a bicycle rack is provided, it must** be located in a safe and convenient location close to building entrances. Clustering of multiple buildings should create pedestrian plazas, courts or patio areas and be linked architecturally with arcades, [trellises,] **trellises** or other similar open structure concepts.



Typical building clusters shall create friendly outdoor spaces.

- 1.2.3 **Except as otherwise provided in this section, site layouts must be designed in a manner such that all buildings front on the primary street of the site with parking areas located to the side or rear of the buildings. A site with multiple buildings may be designed with variations of buildings fronting on the primary street of the**

site with parking areas fronting on the street. Buildings oriented in a "strip" or straight row with parking along the entire street frontage ~~[are not encouraged.]~~ **are prohibited. The Director may waive the requirement for a building to front on the primary street of a site if, at the sole discretion of the Director, a waiver is supported by considerations including lot size, lot shape or any other constraint that may prevent the reasonable placement of a building in a manner fronting the street.**

- 1.2.4 Buildings or other improvements ~~[shall]~~ **must** not impair visibility at street corners or driveway.
- 1.2.5 Detached storage buildings or storage areas ~~[shall]~~ **must** be located towards the rear of a site and be screened with the use of walls, ~~[fencing, and/or]~~ **fencing or landscaping.**

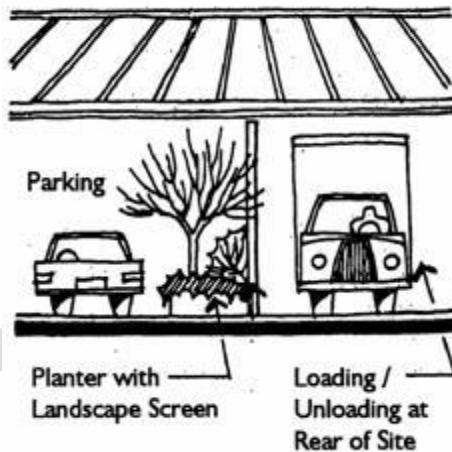

Typical screening of service area.

- 1.2.6 Trash enclosures ~~[shall]~~ **must be provided to screen the storage of any trash receptacle and** be placed **in a manner** so as to be screened from public ~~[right-of-ways]~~ **rights-of-way** and adjacent uses. Outside areas used for the storage of trash, refuse or recycled materials ~~[shall]~~ **must** be completely enclosed by a gate and a ~~[six-foot]~~ **6-foot** masonry block wall ~~[with all]~~ **with all** cells grouted ~~[solid]~~ **solid** and ~~[be]~~ designed to integrate with the site design. Trash enclosures ~~[shall]~~ **must** be screened with ~~[appropriate plant material.]~~ **plant material that is deemed suitable by the Director.**

Trash enclosures ~~[shall]~~ **must** be designed to meet or exceed minimum size requirements **for the proposed use** as determined by the **appropriate** sanitation company and ~~[shall]~~ **must** be ~~[located]~~ **placed in a manner so as** to provide unobstructed access to refuse vehicles. All trash, refuse or recycled material ~~[shall]~~ **must** be stored in containers within its walled enclosure.

- 1.2.7 ~~[Provision]~~ **A provision** for newspaper racks, postal boxes and street furniture ~~[shall]~~ **must** be included, as **deemed** necessary ~~[in]~~ **by the Director for** the overall project design.

1.2.8 All utilities ~~[shall]~~ **must** be supplied to a building or project by underground ~~[service, except]~~ **service except** as **otherwise** approved by the Director.

1.2.9 Non-residential power transformers or other ~~[above ground]~~ equipment ~~[shall]~~ **above ground must** not impair sight distances and ~~[shall]~~ **must** be screened from the adjacent public right-of-way. Consideration ~~[shall]~~ **must** be given to utility company access.

~~[1.2.10 Restaurant and food service businesses shall install a drain that is connected to an approved grease interceptor in accordance with Division 15.]~~

SECTION XXXX:

That Title 18 Appendix (CARSON CITY DEVELOPMENT STANDARDS), Division 1 (LAND USE AND SITE DESIGN), Section 1.3 (Lighting standards) is hereby amended (**bold, underlined** text is added, ~~[stricken]~~ text is deleted) as follows:

1.3 Lighting standards.

~~[This section sets forth]~~ **Except as otherwise superseded by applicable state or federal laws and regulations adopted pursuant thereto, if any, the lighting standards set forth in this section apply to development, other than single-family residential development, located in all zoning districts, and establish** criteria and standards to mitigate impacts caused by lighting and glare.

~~[Lighting Purpose Statement. Office,]~~ **The Board of Supervisors hereby finds and declares that office,** retail, commercial, public, institutional, industrial and multi-family buildings and ~~[their]~~ **the associated** lighting ~~[are part of]~~ **comprise** the overall image of the community. In all cases, ~~[these]~~ **the** standards ~~[stress]~~ **set forth in this section emphasize** the importance of visually identifying and unifying the community character. Unnecessary and improperly designed light fixtures cause ~~[glare,]~~ **glare** or intense light that ~~[results]~~ **result** in unnecessary brightness, a reduction of visual performance and visibility, light pollution and wasted resources through additional expense for utility ~~[costs,]~~ **costs and** hazardous conditions for all modes of transportation, and also ~~[affects]~~ **affect** the ability to view the night sky, including astronomical observations. The following ~~[regulations]~~ **provisions** are intended to mitigate these conditions by ~~[regulations]~~ **establishing criteria** that require shielding, pointing lighting downward ~~[other than]~~ **unless it is** accent ~~[lighting,]~~ **lighting,** only using the amount of light that is necessary and recommending turning fixtures down or off when not required. All new lighting including upward wall lighting must be reviewed and approved by the ~~[director or his designee,]~~ **Director.**

~~[Applicability:]~~

1.3.1 **Existing structures.** All existing structures and residential uses are exempt from this ~~[ordinance and are considered grand fathered]~~ **section and shall be deemed legal nonconforming** improvements. All proposed new commercial developments, buildings, ~~[multi-family]~~ **multi-family** residential complexes of 10 units or more, structures or building additions of 50 percent or more in terms of additional dwelling

units, gross floor area, seating [~~capacity,~~] **capacity** or other units of measurement specified [~~herein, either~~] **in this Title 18 Appendix**, with a single addition or cumulative additions [~~subsequent to the effective date of this provision, shall meet~~] , **must satisfy** the requirements of this [~~Ordinance~~] **section** for the entirety of the property, including all existing and proposed lighting unless **otherwise specifically** exempted [~~under Nonconforming Uses, shown below.~~] **by this section**. For all building additions of less than a cumulative amount of 50 percent, the applicant [~~shall only have~~] **for a development is required only** to meet the requirements of this section for only the new outdoor lighting proposed.

1.3.2 [~~Nonconforming Uses or Structures. Whenever~~] **Abandonment or discontinuation of nonconforming use, structure or building. If** a nonconforming use, structure or building is abandoned **or discontinued** for a period of 12 **continuous** months [~~and then changed to a new use according to the requirements of this code as described in Municipal Code Title 18.04.030 Nonconforming Uses, then~~] **or longer**, any existing outdoor [~~lighting, with the exception of conversion to a residential use of nine units or less, shall be reviewed and~~] **lighting must be** brought into compliance with [~~this code.~~] **the requirements of this section.**

1.3.3 General Requirements . [~~in All Commercial and Industrial Zones:~~]

[~~Light. All nonresidential uses shall provide lighting within~~] **Lighting must be provided in** public parking areas and access ways [~~to provide~~] **for** safety and security. All light sources [~~shall~~] **must** be located and installed in [~~such a way as to prevent spillover lighting onto adjoining properties and glare to the sky. The following provisions shall apply to all proposed development:~~] **accordance with the following requirements:**

1. [~~Any lighting facilities shall be so installed as to project light~~] **Except as otherwise provided in this section, lighting fixtures must be installed in a manner such that light is projected** downward and away from adjoining properties [~~and glare to the sky, with the exception of accent lighting, which is limited to a maximum upward angle of forty five (45) degrees. Site lighting trespass onto adjacent locations and the night sky shall be minimized.~~] Covers must be installed on all lighting fixtures and lamps **or bulbs** must not extend below the bottom of the cover. All [~~light~~] **lighting** fixtures, except [~~street lights, shall~~] **streetlights, must** be located, aimed or shielded so as to minimize stray light [~~trespassing~~] **projecting** beyond property boundaries.
2. [~~All light fixtures that are required to be shielded shall be installed in such a manner that the shielding is installed as designed. Fixtures, which are International Dark Sky Association approved such as Dark Sky Friendly or equivalent, with full cutoff lighting for area and wall pack fixtures are recommended. Sag, convex, drop lenses and luminaries with open bulbs are prohibited.~~]
3. [~~If elevations of buildings are proposed for accent illumination, drawings and a photometric plan shall be provided for all relevant building elevations showing the fixtures, the portions of the elevations to be illuminated, the illuminance levels~~]

of the elevations and the aiming points. The maximum upward angle is forty-five (45) degrees.

4. ~~Light standards, light poles and wall pack] All freestanding and wall mounted lighting adjacent to residential zones ~~[shall] must~~ be limited in height as ~~[follows: Fixtures shall]~~ set forth in this section. Light fixtures must not exceed an overall height of ~~[twelve (12)] 12~~ feet within ~~[seventy-five (75)] 75~~ feet, ~~[sixteen (16)] 16~~ feet within ~~[one hundred (100)] 100~~ feet, ~~[twenty (20)] 20~~ feet within ~~[one hundred twenty five (125)] 125~~ feet, ~~[twenty four (24)] 24~~ feet within ~~[one hundred fifty (150)] 150~~ feet and ~~[twenty eight (28)] 28~~ feet within ~~[one hundred seventy five (175)] 175~~ feet of ~~the~~ property line, or center of street, whichever is closer, when adjacent to residential zones. Additional height may be permitted by the Director ~~[provided such lights are]~~ if the light fixture is a sharp cutoff lighting system. ~~[Illumination levels at the property line of a project shall be reduced by the use of house]~~ Light fixtures must include side shields and reflectors, ~~[and shall be maintained in such a manner as to confine light rays to the premises of the project.]~~ as deemed necessary by the Director, to shield the lamp or bulb from view from any adjacent property line.~~
- ~~[5. No permanent]~~ 3. Except as otherwise provided in this section, permanent rotating searchlights ~~[shall be permitted in any regulatory zone, except that an Administrative Permit]~~ are prohibited in any zoning district that is subject to the lighting requirements set forth in this section. The Director may ~~[be issued by the Director]~~ issue an administrative permit for a temporary rotating searchlight for a period not to exceed ~~[three (3) days for a temporary searchlight. The Administrative Permit shall be limited to a minimum of three (3) times in one (1) calendar year. This prohibition shall not apply to the Carson City Airport.~~
6. ~~Parking area lights are encouraged to be greater in number, lower in height and lower in light level, as opposed to fewer in number, higher in height and higher in light level. A photometric plan is required on all projects with building size of fifty thousand (50,000) square feet or larger and may also be required at the discretion of the Director.~~
7. ~~For all projects where the total initial output of the proposed lighting equals or exceed one hundred thousand (100,000) lumen, certification that the lighting, as installed, conforms to the approved plans shall be provided by a certified engineer before the certificate of occupancy is issued. Until this certification is submitted and reviewed, approval for use of a certificate of occupancy shall not be issued for the project.~~
- ~~8.]~~ 3 days. An administrative permit may be issued to the same person not more than 3 times in a calendar year.
4. Exterior lighting installations ~~[shall] must~~ include timers, dimmers, sensors or photocell controllers that turn the lights off during daylight hours or when lighting is not ~~[needed, which will]~~ to reduce unnecessary lighting, as reasonably practical. Businesses are encouraged to turn lighting down or off when businesses are not open.

~~9. Glare. Reflected glare on nearby buildings, streets or pedestrian areas shall be avoided by incorporating overhangs and awnings, using building materials and colors which are less reflective for exterior walls and roof surfaces, controlling angles of reflection and placing landscaping and screening in appropriate locations.~~

~~1.3.4 Interior lighting. Where residential uses abut non-residential uses,]~~

5. If a residential use abuts a non-residential use, the interior building lighting of the non-residential [uses shall] use must be controlled at night [through] with the use of timers, window blinds or other [acceptable means.] means determined to be acceptable by the Director.

~~[1.3.5 General Lighting Performance Standards. All exterior light fixtures shall use full cut-off luminaries with the light source downcast and fully shielded with no light emitted above the horizontal plane. Again, fixtures which are International Dark Sky Association approved such as Dark Sky Friendly or equivalent with full cutoff lighting for area and wall pack fixtures are recommended. Exceptions are noted below.~~

~~1. Luminaries which have]~~

6. A luminary that has a maximum output of 500 lumen per [fixture, (equivalent to one 40-watt incandescent bulb)] fixture, regardless of the number of bulbs, may be left unshielded [provided the] if each fixture has an opaque top to [keep] prevent light from shining directly [up. Luminaries which have] upward. A luminary that has a maximum output of 850 lumen per [fixture, (equal to one 60-watt incandescent light)] fixture, regardless of the number of bulbs, may be partially [shielded, provided] if the bulb is not visible from off-site, [no] direct glare is [produced,] is not produced and [the] each fixture has an opaque top to [keep] prevent light from shining directly [up.

~~2. Accent Lighting:] **upward. For the purposes of this section, an output of 500 lumen per fixture shall be deemed to be the approximate equivalent of one 40-watt incandescent bulb and an output of 850 lumen per fixture shall be deemed to be the approximate equivalent of one 60-watt incandescent bulb.**~~

7. Architectural features may be illuminated by up-lighting or light directed to the building, such as wall washing, ~~[provided that]~~ **if** the light is effectively aimed to or contained by the structure by such methods as caps, decks, canopies, ~~[marquees, signs, etc,]~~ **marquees or signs**, the lamps are low intensity to produce a subtle lighting ~~[effect,]~~ **effect** and ~~[no]~~ light trespass is **not** produced. The angle of up-lighting ~~[shall]~~ **must** not exceed 45 degrees. Luminaries ~~[shall]~~ **must** not be installed above the height of the parapet or roof. For national flags, statutes, public art, historic buildings or other objects of interest that cannot be illuminated with down-lighting, upward lighting may be used in the form of narrow-cone spotlighting that confines the illumination to the object of interest.

~~[3.]~~ **8.** All luminaries ~~[shall]~~ **must** be aimed and adjusted to provide illumination levels and distribution as indicated on submitted plans. All fixtures and lighting systems ~~[shall]~~ **must** be in good working order, cleaned and maintained in a manner that serves the original design intent of the system.

~~[4.] Floodlights that are not full cut-off (light emitted above the fixture) may be used if permanently directed downward, not upward, and aimed at no more than a 45 degree angle, so no light is projected above the horizontal plane, and fitted with external shielding for top and side to prevent glare and off site light trespass. Unshielded floodlights are prohibited.~~

~~5.]~~ **9.** Sensor activated lighting may be used ~~[provided]~~ **if** it is located in such a manner as to prevent direct glare and lighting into properties of others or into a public right-of-way, and ~~[provided]~~ **if** the light is set to go on only when activated and to go off within ~~[five]~~ **5** minutes after activation has ceased, and the light ~~[shall not be]~~ **is not** triggered by activity off the property.

~~[6.]~~ **10.** Vehicular lights and all temporary emergency lighting ~~[such as]~~ **, including, without limitation,** search lights or any similar high-intensity lights ~~[as needed]~~ **used** by the ~~[fire department, sheriff's office, public works department, Carson City Airport, utility companies, State or Federal Departments]~~ **Fire Department, Sheriff's Office, Department of Public Works, the Carson City Airport, a utility company, a state or federal agency** or **any** other emergency ~~[services shall be exempt]~~ **service, are exempted** from the requirements of this ~~[ordinance.~~

~~7.]~~ **section.**

11. Illumination for outdoor recreation facilities must conform to the shielding ~~[requirements,]~~ **shielding requirements set forth in this section,** except when such shielding would interfere with the intended activity. For such facilities, partially-shielded luminaries are permitted. Examples ~~[of]~~ **of** activities where partially-shielded luminaries are permitted ~~[include, but are not limited to,]~~ **include, without limitation,** baseball, softball and football. Fully-shielded luminaries are required for tennis, volleyball, racquetball, handball courts and swimming pools. ~~[Rotating]~~ **This subsection does not apply to rotating** airport beacons ~~[are exempt from this requirement.]~~

~~[8.] Service Station/Canopy Lighting. All luminaries mounted on the under surface of service station canopies shall be fully shielded and utilize flat covers. All lighting shall be recessed sufficiently so as to ensure that no light source causes glare on public rights of way or adjacent property. A maximum of 850 lumen per fixture is allowed (equivalent to one 60 watt incandescent bulb).~~

~~9.] Temporary Lighting. The director]~~

12. **The Director** may grant a permit for temporary ~~[lighting, which]~~ **lighting that** does not conform to the provisions of this ~~[ordinance if the applicant meets]~~ **Division, subject to** the following criteria: ~~[the purpose for which the lighting is proposed does not extend beyond 60 days, but may be granted a 30 day extension after review by the Director. The director will rule on the application within 5 business days of the date of submission of the request, and notify the applicant in writing of the decision.]~~

a. The proposed lighting must be designed in such a manner as to minimize light trespass and glare to the sky.

- b. ~~[It will]~~ **The proposed lighting must** be a temporary use and ~~[will be in the]~~ **is in furtherance of a** public interest.
- c. ~~[The application for temporary lighting shall]~~ **An application for the proposed lighting is submitted to the Director in writing. The application must** include the following information:

The name and address of the applicant and property owner, a site plan showing **the** entire site and location of proposed luminaries, **and** manufacturers specification sheets showing type, wattage and height of ~~[lamp(s)]~~ **lamps** with type and shielding of proposed luminaries, or if not new, pictures of previous sites or of the fixtures proposed to be used.

The Director shall issue a written decision as soon as reasonably practicable after an application is submitted pursuant to this subsection. The Director shall not authorize the temporary use of any proposed lighting that does not conform to the requirements set forth in this section for any period exceeding 60 consecutive days.

~~[10. Maintenance.]~~

- 13.** All fixtures ~~[shall]~~ **must** be maintained in good working order, with aiming, angles, wattage and intensity as originally approved. Replacement bulbs ~~[shall]~~ **must** be the same or less wattage and intensity as originally approved. Fixtures and reflecting surfaces ~~[shall]~~ **must** be cleaned on a regular schedule to reduce additional unapproved glare.

~~[11. The director]~~

- 14.** **The Director** may approve variations to the standards set ~~[out]~~ **forth** in this Division if variations are more appropriate to a particular site, provide an equivalent means of achieving the intent of these lighting standards and are ~~[in keeping]~~ **consistent** with the purpose statement of this ~~[section.]~~ **Division.** A **written** letter of request ~~[detailing the reason for the]~~ **for any** variation ~~[and changes requested is required to]~~ **must** be submitted to the ~~[director.]~~ **Director** **and include a detailed explanation for the request. The Director shall issue a written decision as soon as reasonably practicable after a letter of request is submitted pursuant to this section.**

~~[12. These standards are enforced under Title 18.020.030 (Enforcement).]~~

SECTION XXXX:

That Title 18 Appendix (CARSON CITY DEVELOPMENT STANDARDS), Division 1 (LAND USE AND SITE DESIGN), Section 1.4 (Guest building development) is hereby amended (**bold, underlined** text is added, ~~[stricken]~~ text is deleted) as follows:

1.4 ~~Guest building development.~~

Guest building refers to a dwelling unit on the same lot as the primary dwelling unit and ancillary to it. ~~A guest building]~~ **Accessory dwelling units.**

An accessory dwelling unit may provide complete, independent living facilities for ~~[±]~~ **one** or more persons, including permanent facilities for living, sleeping, eating, cooking and sanitation. ~~[Typical uses include guest houses, second units, extended family housing and caretaker's quarters.]~~ **A person may request approval of an accessory dwelling unit by submitting an application to the Director. The application must be made on a form prescribed by the Department and include a site plan. The Director shall issue a written decision as soon as reasonably practicable after an application is submitted pursuant to this section.**

- 1.4.1 A site plan ~~[shall be submitted indicating]~~ **that is submitted pursuant to this section must contain** the ~~[following:]~~ **following information:**
- a. Location of **the accessory dwelling unit that shows the setback distances from the property line, the** primary residential structure ~~[with setback distances, distance to guest building]~~ and **any** other accessory structures.
 - b. Location of all public and private utilities ~~[and/or well]~~ **and any wells** ~~[and septic tank/leach field:]~~ **, septic tanks and leach fields.**
 - c. Access to primary residential structure and ~~[guest building:]~~ **accessory dwelling unit.**
 - d. ~~[Zoning,]~~ **Identification of zoning,** size of lot, ~~[assessors]~~ **Assessor's** parcel number, north arrow, ~~[scale,]~~ **scale and** location of other ~~[outbuildings:]~~ **outbuildings, if any.**
 - e. **A statement attesting that the proposed use and site plan do not conflict with any private restrictions on the property.**
- 1.4.2 ~~[Recordation. The property owner shall, prior to the issuance of a certificate of occupancy for the building permit, record a deed restriction against the subject property with the city recorder's office stating the guest building occupation limitations contained in Section 1.4.10.]~~ **Minimum lot size. An attached accessory dwelling unit may only be located on a lot that is 6,000 square feet or larger. A detached accessory dwelling unit may only be located on a lot that is 12,000 square feet or larger. For the purposes of this section, an accessory dwelling unit shall be deemed attached if the unit shares a common wall with the primary residential structure for a contiguous distance of not less than 10 feet.**
- 1.4.3 Existing ~~[Guest Buildings. Existing guest buildings]~~ **An existing accessory dwelling unit** may expand to include a kitchen facility only upon full compliance with the provisions of this ~~[division:]~~ **Division.** Approval of a building permit is required if the structure itself is being altered.
- 1.4.4 Maximum Size. ~~[Guest building living]~~ **The living** space gross floor **of an accessory dwelling unit** area ~~[shall]~~ **must** not exceed 50 percent of the assessed floor area of the ~~[main residence,]~~ **primary residential structure,** excluding garages,

basements and other accessory structures, or the following limitations, whichever is less:

- a. In the SF6, MH6, SF12 and MH12 zoning ~~[districts,]~~ **districts and on other residentially zoned lots of less than 21,000 square feet in area**, a maximum of 700 square ~~[feet,]~~ **feet**.
 - b. In all other single family residential **zoning** districts, a maximum of 1,000 square ~~[feet.]~~ **feet if the lot size is 21,000 square feet or greater in area**.
- 1.4.5 Required ~~[Setbacks. All guest buildings shall]~~ **setbacks. All accessory dwelling units must** meet the same setbacks as required for the primary ~~[residence]~~ **residential structure located** on the ~~[lot, provided that]~~ **lot. If the unit has a** second story ~~[elements of a guest building are]~~ **, the unit must be** a minimum of 20 feet from all property lines.
- 1.4.6 Maximum ~~[Building Height. The guest building shall]~~ **building height. An accessory dwelling unit must** meet the maximum height requirements of the zoning district in which it is ~~[located, provided that second story elements of a guest building are a minimum of 20 feet from all property lines.]~~ **located**.
- 1.4.7 Required ~~[Parking.]~~ **parking**. A minimum of 1 off-street parking space or, for ~~[guest buildings]~~ **an accessory dwelling unit** with multiple bedrooms, 1 parking space per bedroom ~~[shall]~~ **must** be provided outside of the required front-yard setback area in addition to the required parking for the ~~[main residential use.]~~ **primary residential structure**. In the SF6, MH6, SF12 and MH12 zoning districts, the guest parking must be provided on a paved surface.
- 1.4.8 Site ~~[Design.]~~ **design**.
- a. Architectural design and materials for ~~[a guest building shall]~~ **an accessory dwelling unit must** be consistent and compatible with the design and materials of the ~~[main]~~ **primary residential** structure, including ~~[but not limited to]~~ **, without limitation**, roof pitch, roof materials, siding materials and ~~[color,]~~ **color** and **any** other architectural ~~[features,]~~ **features**.
 - b. Only one entrance **to the accessory dwelling unit** may be visible from the street frontage.
- 1.4.9 Modifications ~~[to These Provisions.]~~
- a. The ~~[above guest building provisions]~~ **requirements set forth in this Division** relating to **the** size, height and site design **of an accessory dwelling unit** may only be modified by **the** approval of a special use ~~[permit,]~~ **permit**.
 - b. The ~~[above guest building provisions]~~ **requirements set forth in this Division** relating to setbacks and parking **for an accessory dwelling unit** may only be modified by **the** approval of a variance.
- 1.4.10 ~~[Guest Building Occupation. A guest building may only be occupied by the family members of the primary residence, as defined by Title 18 of the Carson City Municipal Code, and their non-paying guests. Guest buildings may not be rented as secondary dwelling units.]~~ **Water and sewer connections. Except as otherwise authorized by**

the Director of the Department of Public Works, a detached accessory dwelling unit must have a water and sewer connection that is separate from the water and sewer connection providing service to the primary residential structure.

1.4.11 Occupancy requirement. An accessory dwelling unit may only be used as a dwelling if the owner of record resides on the property. Before a certificate of occupancy may be issued for an accessory dwelling unit, a deed restriction containing the occupancy requirement set forth in this section must be recorded against the property.

SECTION XXXX:

That Title 18 Appendix (CARSON CITY DEVELOPMENT STANDARDS), Division 1 (LAND USE AND SITE DESIGN), Section 1.5 (Not used) is hereby repealed (**bold, underlined** text is added, [~~stricken~~] text is deleted) as follows:

[1.5 Not used.]

SECTION XXXX:

That Title 18 Appendix (CARSON CITY DEVELOPMENT STANDARDS), Division 1 (LAND USE AND SITE DESIGN), Section 1.6 (Child care facilities performance standards) is hereby amended (**bold, underlined** text is added, [~~stricken~~] text is deleted) as follows:

1.6 Child care [~~faelities~~] facility performance standards.

The standards set forth in this section apply to the development of child care facilities located in all zoning districts. The purpose of these standards is to promote the health, safety and general welfare of the residents of Carson City by establishing development standards that recognize and consider the need for such facilities and whether their proposed locations are compatible with surrounding areas. The following performance standards [~~shall~~] **must** be used in **the** review of individual special use permit requests for child care facilities in addition to **any** other [~~standards of this title.~~] **applicable standard set forth in CCMC.**

1. The size, client density and operational characteristics, including, [~~but not limited to,~~] **without limitation,** the number of employees, hours of operation and [~~loading/unloading~~] **the loading and unloading** area of a proposed child care facility within a residential zoning district [~~shall~~] **must** be compatible with and [~~shall~~] not adversely affect adjacent residents [~~pursuant to~~] **as may be prohibited by** the requirements of [~~this chapter. Consideration shall be given to the following:~~] **CCMC.**

The construction of any child care facility must be similar in scale, bulk and site coverage to the immediately surrounding neighborhood in which the facility is located. The review for approval of a child care facility must also incorporate the following considerations:

- a. ~~[With the construction of, or approval of, new facilities, the facility shall be similar in scale, bulk and site coverage with that of the immediate neighborhood;~~
 - ~~b.]~~ The availability of public facilities, services and utilities;
 - c. ~~[Emphasis on maintaining]~~ **The manner in which the existing character of any residential neighborhood [character;] where a child care facility is proposed to be located will be maintained; and**
 - d. The generation of traffic and the capacity and physical character of surrounding streets.
2. Parking ~~[shall]~~ **for a child care facility must** meet the requirements ~~[of Division 2 (Parking and Loading) of the development standards.]~~ **set forth in this Title 18 Appendix.**
 3. ~~[Landscaping. In the design of parking area landscaping, considerations shall be given to the]~~ **The retention of existing trees and [shrubby.] shrubbery must be considered in the design of parking area landscaping.**
 4. ~~[Signs. This section shall apply exclusively to signs for child care facilities located within a residential zoning district. Compliance with Division 4 (Signs) of the development standards shall not be required for a child care facility. The board find and declare that an on-site sign to "advertise or promote" the facility is not necessary. On-site identification of the address and logo no greater than 2 square feet in size distinctive to a particular child care facility used as a public convenience in identifying the site for the public shall be permitted.]~~ **Notwithstanding any other provision of CCMC, one onsite identification sign of not greater than 6 square feet in size may be used for a child care facility.**
 5. ~~[If the facility's structure]~~ **If a child care facility is proposed to be** located within the historic district, ~~[then]~~ **the** design and ~~[material shall require review and approval]~~ **use of all materials in the construction of the facility must be approved** by the ~~[HRC.]~~ **Historic Resources Commission.**
 6. ~~[Open Space. Open]~~ **Any open** space requirements ~~[shall be designated and regulated by the Carson City health department prior to approval of the special use permit.]~~ **that are imposed by the applicable state licensing agency for child care facilities must be shown on site plans that are submitted for approval.**
 7. ~~[Interior Space Requirement for Children. The]~~ **Any** interior space requirements ~~[shall be designated and regulated by the Carson City health department prior to approval of the special use permit.]~~ **that are imposed by the applicable state licensing agency for child care facilities must be shown on site plans that are submitted for approval.**

8. ~~[Child care facilities]~~ **A child care facility** may be established in the ~~[general industrial]~~ **General Industrial (GI) and General Industrial Airport (GIA)** zoning ~~[district]~~ **districts** only as an accessory use to a permitted primary use.
9. [In] **A child care facility that is located in any** residential zoning ~~[districts, a child care facility]~~ **district** may only be established as an accessory use to the residential use of the ~~[structure,]~~ **structure** and the residence must be occupied by the operator as a primary residence.

SECTION XXXX:

That Title 18 Appendix (CARSON CITY DEVELOPMENT STANDARDS), Division 1 (LAND USE AND SITE DESIGN), Section 1.7 (Bed and breakfast inn performance standards) is hereby amended (**bold, underlined** text is added, ~~[stricken]~~ text is deleted) as follows:

1.7 Bed and breakfast inn performance standards.

The standards set forth in this section apply to the development of bed and breakfast inns located in all zoning districts. The purpose of these standards is to facilitate the provision of transient occupancy, lodging and limited meals, primarily within the historic district of the City and residential zoning districts in which bed and breakfast inns are permitted. The intent of this section is to provide certain economic incentives to the owners of qualifying properties while showcasing the unique beauty of the historic homes. It is also the intent of this section to establish safeguards for the protection of existing architectural and historic character of neighborhoods.

The ~~[following]~~ performance standards ~~[shall]~~ **set forth in this section must** be used in ~~the~~ review of individual **requests for a** special use permit ~~[requests]~~ for bed and breakfast inn uses in addition to ~~[the]~~ **any** other **applicable** standards ~~[of this title.]~~ **set forth in CCMC.**

1. The location, size, design and operation characteristics of ~~[the]~~ **a** proposed bed and breakfast inn ~~[shall]~~ **must** be compatible with and ~~[shall]~~ not adversely affect adjacent uses and residents. ~~[Consideration shall be given to:]~~ **The review for approval of a proposed bed and breakfast inn must incorporate the following considerations:**
 - a. Harmony in scale, bulk, site coverage and density of all associated improvements and alterations;
 - b. The availability of public facilities, ~~[services,]~~ **services** and utilities;
 - c. The effect upon desirable neighborhood character;
 - d. The generation of traffic and the capacity and physical character of surrounding streets;
 - e. The suitability of the site for the use ~~[which]~~ **that** is proposed, including available parking in relation to **the** intensity of use; **and**

- f. ~~[Other]~~ **Any other** relevant impacts of the proposed use.
2. Parking. In all **zoning** districts, 1 off-street parking space per guest room and 2 off-street parking spaces for the owner resident ~~[shall be]~~ **are** required. On an individual basis, consideration may be given to off-premises and on-street parking as a part of the bed and breakfast inn special use permit.

Replacement of existing landscaping ~~[(including)]~~ **, including, without limitation,** lawns and ground ~~[cover]~~ **cover,** with paving for parking use ~~[shall]~~ **must** be avoided whenever possible.

Consideration ~~[shall]~~ **must** be given to allowing parking within landscaped areas by utilizing paver stones, turf stones, decorative ~~[gravel,]~~ **gravel** or other alternatives to asphalt or concrete paving.

3. Landscaping:
- a. Parking areas and exterior waste receptacles ~~[shall]~~ **must** be screened by a ~~[wooden]~~ fence in conjunction with an earth berm ~~[and/or]~~ **or** shrubbery. The combination of screening ~~[shall]~~ **must** be ~~[at least]~~ **not less than** 4 feet in height.
 - b. In **the** design of landscaped areas, consideration ~~[shall]~~ **must** be given to **the** retention of existing trees, harmony with setting and structure, strengthening of vistas and seasonal shade.
4. Signs. ~~[This section shall apply exclusively to signs for bed and breakfast inns. Compliance with Division 4 (Signs) of the development standards shall not be required for a bed and breakfast inn business. The board finds and declares that an on-site sign to "advertise or promote" the business is not necessary. On-site identification of the address and a small logo distinctive to a particular inn used as a public convenience in identifying the site for guests shall be permitted.]~~ **Notwithstanding any other provision of CCMC, one onsite identification sign of not greater than 6 square feet in size may be used for a bed and breakfast inn.**
- a. The main performance criteria for bed and breakfast inn signs ~~[shall be]~~ **are** design, materials and location ~~[which are]~~ **, which must be** compatible with the architecture, colors and materials of the subject residence and ~~[which enhances]~~ **enhance** the character of the neighborhood.
 - b. Within the historic district, signs for bed and breakfast inns ~~[shall]~~ **must** be limited to 1 per establishment, not to exceed a cumulative total of 3 square feet in size and consisting of the name and address only. Any sign illumination ~~[shall]~~ **must** be exterior to the sign and shielded so as not to glare upon an adjacent property or public right-of-way. Backlighting ~~[shall be]~~ **for signs is** prohibited. Siting ~~[shall]~~ **of a sign must** be ~~[either]~~ **freestanding or placed** on the structure or a ~~[fence, or shall be freestanding,]~~ **fence.** If **a sign is** freestanding, the sign ~~[shall]~~ **must** not exceed 3 feet in height. Design materials and colors ~~[shall]~~ **of a sign must** be compatible with the style and detailing of the residence and ~~[shall require review and approval of the HRC.]~~ **must be reviewed and approved by the Historic Resources Commission.**

- c. Outside the historic district, signs ~~[shall]~~ **must** be approved on an individual basis at the time of special use permit approval. ~~[Regardless of the zoning district, signs shall]~~ **In all zoning districts, signs must** be reviewed ~~[in terms of]~~ **for** good design, compatibility with **the** surrounding neighborhood, materials and identification ~~[as opposed to]~~ **purposes rather than for** advertisement.
5. Number of Guest Rooms.
- ~~[a.—A maximum number of]~~ **A bed and breakfast inn may not have more than 5** guest bedrooms ~~. [shall be allowed.]~~
 - ~~[b.—A minimum of 2 guest bedrooms shall be allowed.]~~
6. Ancillary Uses.
- a. The sale or display of merchandise or other commodities ~~[shall be]~~ **in a bed and breakfast inn is** prohibited unless **expressly** allowed in the ~~[specific]~~ zoning district **in which the bed and breakfast inn is located** and ~~[the required public facilities,]~~ **any public facilities required by CCMC,** including **, without limitation,** parking, are provided.
 - b. Except for personal use of the owner, private weddings, receptions, luncheons, cocktail parties and any other such functions for which the owner receives consideration for the use of the inn ~~[shall]~~ **must** be regulated in frequency and manner by the special use permit. ~~[Such ancillary functions shall be sponsored by paying guests at the inn.]~~
 - ~~c.—Bed and breakfast inns which are located outside the historic district shall not be limited in the number of social functions, except as otherwise established in the zoning district, or by special use permit.~~
 - ~~d.—Each~~ **c. An** owner who manages a bed and breakfast inn shall obtain a permit for the facility from the Carson City ~~[health department prior to the validation of]~~ **Department of Health and Human Services before** a special use ~~[permit.]~~ **permit may be issued.**
 - ~~[e.]~~ **d.** The ~~[fire department]~~ **Fire Department** shall inspect and approve all bed and breakfast inns ~~[prior to validation of a special use permit.]~~ **before the issuance of any certificate of occupancy.**

SECTION XXXX:

That Title 18 Appendix (CARSON CITY DEVELOPMENT STANDARDS), Division 1 (LAND USE AND SITE DESIGN), Section 1.8 (Satellite dishes and antennas) is hereby repealed (**bold, underlined** text is added, ~~[stricken]~~ text is deleted) as follows:

~~1.8 Satellite dishes and antennas.~~

~~Satellite dish antennas exceeding 18 inches in diameter are subject to the following conditions:~~

1. ~~Location and Placement.~~
 - a. ~~All antennas must be ground mounted. If ground mounting is not feasible, or special circumstances exist, an alternative location, such as roof mounting, may be approved subject to a special use permit.~~
 - b. ~~Shall not be located within any front or street side yard setback, nor visible from the front or street side property line.~~
 - c. ~~All cables and lines serving the antenna shall be located underground.~~
2. ~~Height and Dimensions.~~
 - a. ~~In residential districts, the antenna shall not exceed 12 feet in height above grade and 10 feet in diameter.~~
3. ~~Setbacks.~~
 - a. ~~The antenna shall set back from any side or rear property lines a minimum distance of 5 feet, or the applicable setback requirement for the respective use district in which it is located, whichever is greater.~~
 - b. ~~If lot is irregular in shape, or other special circumstances exist, a variance may be requested from the standards listed above.~~
4. ~~Screening and Design.~~
 - a. ~~Satellite dish antennas shall be consistent in color with the surrounding natural or built environment.~~
 - b. ~~Non-residential satellite dish antennas located adjacent to residentially zoned property and which exceed 10 feet in diameter shall require screening in accordance with adopted Carson City standards.]~~

SECTION XXXX:

That Title 18 Appendix (CARSON CITY DEVELOPMENT STANDARDS), Division 1 (LAND USE AND SITE DESIGN), Section 1.9 (Wireless telecommunication facilities and equipment) is hereby amended (**bold, underlined** text is added, ~~stricken~~ text is deleted) as follows:

1.9 Wireless telecommunication facilities and equipment.

~~[Regulations and]~~ **The** standards set forth in this ~~[section]~~ **section apply to the placement of wireless communication facilities and equipment in all zoning districts and** are designed to address ~~[wireless telecommunication]~~ **such** facilities and equipment used for the commercial ~~[broadcasting/receiving]~~ **broadcasting and receiving** of transmissions regulated under the Telecommunications Act of ~~[1996. Definitions for the various uses and terms referenced in this section are included in the Section 18.03 (Definitions). Electrical]~~ **1996, Public Law 104-104, 100 Stat. 56-161, as may be amended. Any electrical** or mechanical equipment that creates video or audio interference in customary residential electrical appliances or causes fluctuations in line voltage outside the dwelling unit is prohibited.

1. Location and Placement Standards.
 - a. Facilities and equipment ~~[shall]~~ **must** be located ~~[according to the following priorities, (#1 is the most acceptable, #5 is the least acceptable):]~~ **in a manner corresponding to the descending order of priorities as follows:**
 - (1) Concealed within an existing structure;
 - (2) Camouflaged or screened within an existing structure;
 - (3) Camouflaged or screened on an existing structure, particularly existing telecommunications facilities, utility poles and towers, water ~~[towers,]~~ **towers** and commercial, industrial or public facility buildings;
 - (4) Co-located with existing wireless communication service facilities; **or**
 - (5) ~~[Erection of]~~ **Erected as** a new, freestanding facility subject to ~~[either]~~ **the** requirements of this section and where visual impact can be minimized ~~[and/or]~~ **or** mitigated.
 - b. ~~[The applicant shall]~~ **An applicant must** adequately justify the location proposed based on a consideration of the ~~[above priorities.]~~ **priorities described in subsection 1.**
 - c. Placement on existing structures ~~[shall]~~ **must** not jeopardize the character and integrity of the structures as determined by the ~~[building and/or engineering department.]~~ **Building Division or Development Engineering Division of the Department.**
 - d. ~~[If ground-mounted,]~~ **Ground-mounted** facilities and equipment ~~[shall]~~ **must** not be located in the front yard portion of a parcel with an existing structure.
 - e. ~~[Either the applicant]~~ **An applicant** or co-applicant must be a carrier licensed by the Federal Communications Commission . ~~[and.]~~ **He or she must** submit documentation of the legal right to install and use the proposed facility.
2. Height and Dimensional Standards.
 - a. ~~[The height of the facility shall include any]~~ **Any** antenna, array or other ~~[appurtenances.]~~ **appurtenance must be included for the purpose of calculating the total height of a facility.**
 - b. Facilities ~~[shall]~~ **may** not exceed 120 feet in height above grade. The applicant **for the facility** must provide a written justification for the proposed use and adequately demonstrate that the proposed height is necessary, including co-location opportunities. The applicant ~~[shall]~~ **must** submit a report from an independent, accredited source providing justification for the proposed height or an alternative lower height.
3. Setbacks.
 - a. All facilities, equipment and equipment shelters ~~[shall]~~ **must** comply with the building setback provisions of the zoning district in which they are located.
 - b. ~~[Roof mounted facilities shall]~~ **Roof-mounted facilities must** be stepped back from the front facade ~~[in order]~~ to limit their impact on the ~~[building's silhouette]~~

~~and/or]~~ **silhouette of the building, or be otherwise** concealed, camouflaged or screened.

- c. Facilities and equipment ~~[shall]~~ **must not** be located ~~[no]~~ closer than 4 times the facility height from any residentially zoned property.
4. Design Standards.
- a. ~~[Ground-mounted]~~ **Ground-mounted** facilities and equipment **that are** not camouflaged by design, existing buildings or structures ~~[shall]~~ **must** be screened according to adopted Carson City standards, including landscaping and screen walls.
 - b. Facilities and equipment that are ~~[side-mounted]~~ **side-mounted** on buildings ~~[shall]~~ **must** be consistent with the architectural style and color of the building on which ~~[it is]~~ **they are** mounted.
 - c. Ground and ~~[roof-mounted facilities shall]~~ **roof-mounted facilities must** be painted a non-glossy color that blends with the surrounding natural and built environment.
 - d. Equipment shelters **that are** not placed underground ~~[shall]~~ **must** be appropriately screened ~~[according to]~~ **in accordance with** adopted Carson City standards.
 - e. New, ~~[stand-alone facilities shall]~~ **standalone facilities must** be designed to allow additional wireless service providers to co-locate antennas on the structure.
 - f. ~~[The]~~ **Except for emergency lighting that are manually operated, the** exterior of facilities and equipment ~~[shall]~~ **must** not be lighted unless required by the Federal Aviation Administration ~~[(FAA)]~~ ~~with the exception of manually operated emergency lighting.]~~
 - g. All ~~[ground-mounted]~~ **ground-mounted** facilities and equipment ~~[shall]~~ **must** be surrounded by a security barrier. The barrier ~~[shall]~~ **must** contain adequate controlled access and be posted with a 1 square foot sign ~~[indicating]~~ **identifying** the facility ~~[owner(s)]~~ **owner** and **displaying** a 24-hour emergency telephone number.

SECTION XXXX:

That Title 18 Appendix (CARSON CITY DEVELOPMENT STANDARDS), Division 1 (LAND USE AND SITE DESIGN), Section 1.10 (Personal storage and metal containers) is hereby amended (**bold, underlined** text is added, ~~[stricken]~~ text is deleted) as follows:

1.10 Personal storage ~~, [and metal storage containers.]~~

~~[Trends indicate that]~~ **The standards set forth in this section apply to the use of personal storage located in all zoning districts. The Board of Supervisors hereby declare that trends indicate** as communities continue to grow, the need for personal storage uses also increases.

With the continued development of upscale subdivisions prohibiting on-site storage of vehicles or other items, personal storage facilities are becoming increasingly necessary. ~~[Commercial locations may also require additional storage in metal storage containers. The following [section sets] **This section** sets forth criteria and standards for the development of personal storage facilities . [and metal storage containers.]~~

Personal ~~[Storage:]~~ **storage facilities.**

1. ~~[A minimum of 60% of the lot's street frontage(s) shall]~~ **Not less than 60 percent of the street frontage of any lot on which a personal storage facility is located must** be developed with retail ~~[and/or]~~ **or** office space **if the lot is** in the ~~[neighborhood business, retail commercial and tourist commercial (NB, RC and TC) zoning districts only.]~~ **Neighborhood Business (NB), Retail Commercial RC or Tourist Commercial (TC) zoning districts.**
2. A sight-obscuring ~~[entrance gate and]~~ perimeter opaque fence or wall ~~[shall]~~ **must** be provided to screen views of individual storage units. **A vehicular entrance gate is not required to be opaque.**
3. The architectural and site design of the ~~[retail/office]~~ **retail or office** building, storage units, perimeter fencing, ~~[lighting,]~~ **lighting** and landscaping ~~[is]~~ **are** subject to approval by the ~~[director. A metal pre-fabricated]~~ **Director. Any metal prefabricated** exterior ~~[office/retail]~~ **office or retail** building is prohibited.
4. ~~[No business activities]~~ **Any business activity** other than storage ~~[shall be conducted]~~ **is prohibited** within individual storage units.
5. Outside storage is prohibited except as ~~[expressly permitted in]~~ **otherwise specifically authorized by** Title 18 **of CCMC** or ~~[the development standards. Storage containers may be utilized in industrial districts to house storage items within them. Temporary storage containers are allowed at construction sites for a maximum of 30 days, or as approved by the director after review of the individual construction schedule.]~~ **the provisions set forth in this Title 18 Appendix.**
6. ~~[Additionally, storage]~~ **Storage** units adjacent to residential areas ~~[shall:]~~ **must:**
 - a. ~~[Not exceed 14 feet in height (1 story);~~
 - b. ~~[Have a minimum [20 foot]~~ **20-foot** landscape buffer and a solid ~~[6 foot]~~ **6-foot** masonry wall located between the storage units and residential uses;
 - ~~[e:]~~ **b.** Have limited hours of operation **of between** 7:00 a.m. to 7:00 p.m. unless otherwise approved by the ~~[planning commission;]~~ **Planning Commission; and**
 - ~~[d. Have a monument style sign not]~~ **Not have any sign** exceeding 6 feet in height.
- ~~[7. Shared use parking shall not exceed 5% of total parking.]~~
- ~~8. Must meet the definition as defined in CCMC 18.03.~~
- ~~9. Metal storage containers, as defined in CCMC 18.03 is a fully enclosed unit, excluding semi-truck trailers, that house storage items and may be utilized in any~~

~~industrial, public or commercial zoning district, excluding the neighborhood business (NB) zoning district, in conjunction with a permitted primary use of the property subject to the following use performance standards:~~

- ~~a. Metal storage containers may be utilized on a temporary basis, for a maximum of 90 days, once in any calendar year, subject to the approval of the director.~~
- ~~b. Within any industrial zoning district, the use of metal storage containers on a permanent basis is subject to the approval of the director.~~
- ~~c. Within the commercial or public zoning districts, excluding the neighborhood business (NB) zoning district, the use of metal storage containers on a permanent basis beyond 90 days requires approval of a special use permit. No metal storage containers are allowed in the neighborhood business (NB) zoning district.~~
- ~~d. The use of metal storage containers within the downtown commercial (DC) zoning district also requires approval by special use permit and downtown design review approval pursuant to 18.07 and development standards Division 6.~~
- ~~e. Metal storage containers shall be used for storage purposes only and no human occupation shall occur. No alterations shall be made or allowed to the metal storage container including, but not limited to, doors, windows, electrical, plumbing, or connection of multiple containers unless factory built with those improvements. No storage shall be placed upon or above the metal storage container. Storage containers shall not be stacked upon each other.~~
- ~~f. No hazardous materials shall be stored in metal storage containers. Metal storage containers shall not be sited in a manner to be detrimental to the public's health and safety.~~
- ~~g. Metal storage containers shall be at building grade and located at the side or rear of the primary structure. Metal storage containers shall not occupy any required parking spaces, landscape areas, drive aisles, firelanes, drainage courses, drainage easements, detention basins, or vehicular or pedestrian access ways. Metal storage containers shall not be permitted on vacant property.~~
- ~~h. All metal storage containers shall be painted either to blend with the primary or adjacent structures or painted earth tone colors to minimize visual impacts. Graffiti shall be removed in accordance with the city's graffiti ordinance. All metal storage containers in use shall be in a condition free from rust, peeling paint, or other visible forms of deterioration. Metal storage containers shall be screened with chain link fencing with slats, concrete masonry unit (CMU) block walls and/or landscaping as approved by planning staff. Metal storage containers and their screening and landscaping shall be maintained in good repair. Any metal storage containers that are not~~

~~maintained in good repair or that are dilapidated or dangerous, shall be repaired or removed, following an order to comply from the director.~~

- ~~i. Advertising is prohibited on the exterior of all metal storage containers.~~
- ~~j. The use of semi-truck trailers as storage containers is prohibited in all zoning districts.~~
- ~~k. The number of metal storage containers allows for a business is dependent upon the following list of factors:
 - ~~(1) Overall site placement;~~
 - ~~(2) Screening provisions;~~
 - ~~(3) Square footage of store or building;~~
 - ~~(4) Square footage of parcel;~~
 - ~~(5) Adjacency to residential zoning districts;~~
 - ~~(6) Length of stay of metal storage container;~~
 - ~~(7) Applicants justification/need for extra on-site storage for their business.~~~~
- ~~l. A metal storage container special use permit shall be reviewed in 5-year increments or at any time the principal property use changes, with a \$50.00 administrative service charge and noticing costs paid by applicant.~~
- ~~m. Special use permit fees for metal storage containers as adopted by resolution of the board, shall be charged, collected and deposited with the planning and community development department.]~~

SECTION XXXX:

That Title 18 Appendix (CARSON CITY DEVELOPMENT STANDARDS), Division 1 (LAND USE AND SITE DESIGN) is hereby amended (**bold, underlined** text is added, [~~stricken~~] text is deleted) by adding thereto a new Section 1.103 (Metal storage containers) as follows:

1.103 Metal storage containers.

1. The standards set forth in this section apply to the placement of metal storage containers, commonly known as CONEX boxes, in all zoning districts. Metal storage containers may be used in industrial districts to house storage items. Temporary metal storage containers are allowed at construction sites for not more than 30 days unless otherwise specifically authorized by the Director and only after the Director has reviewed the applicable construction schedule. The provisions of this section shall not be interpreted to prohibit the use of a metal storage container as a building material if the use is consistent with CCMC and the International Building Code, as adopted by the City.

2. The use of a metal storage unit in the Neighborhood Business (NB) zoning district and on single-family lots of that are smaller than 1 acre in size is prohibited. A metal storage container may be used in any industrial, public or commercial zoning district in conjunction with a permitted primary use of the property subject to the following use performance standards:

- a. Metal storage containers may be used on a temporary basis for not more than 90 days, once in any calendar year, subject to the approval of the Director.**
- b. The permanent use of a metal storage container in any industrial zoning district must be approved by the Director.**
- c. The use of a metal storage container in any commercial or public zoning district for a period longer than 90 days must be approved by a special use permit.**
- d. The use of a metal storage container in the Downtown Commercial (DC) zoning district must be approved by a special use permit.**
- e. The use of a metal storage container is limited exclusively to storage purposes. The use of a metal storage container for occupancy by a person is prohibited. Storage items may not be placed upon or above a metal storage container. Metal storage containers may not be stacked upon each other.**
- f. A metal storage container may not be sited in a manner that is detrimental to the health and safety of the public.**
- g. Metal storage containers must be at building grade and located at the side or rear of the primary structure. A metal storage container may not occupy any required parking space, landscape area, drive-aisle, fire lane, drainage course, drainage easement, detention basin or vehicular or pedestrian access way. The placement of a metal storage container on vacant property is prohibited.**
- h. All metal storage containers must be painted to blend with the primary or adjacent structures or painted earth tone colors to minimize visual impacts. The appearance of any graffiti must be removed in accordance with the applicable provisions of CCMC. All metal storage containers in use must be maintained in a condition free from rust, peeling paint and other visible forms of deterioration. Metal storage containers must be screened with chain link fencing with slats, concrete masonry unit block walls or landscaping as approved by the Department. Metal storage containers and associated screening and landscaping must be maintained in good repair. Any metal storage container that is not maintained in good repair or that is deemed dilapidated or dangerous at the discretion of the Director must be repaired or removed pursuant to written directive from the Director.**
- i. The use of any advertisement on the exterior of a metal storage container is prohibited.**
- j. The use of a semi-truck trailer as a metal storage container is prohibited.**

k. The number of metal storage containers allowed for a business is subject to determination by the Director. In determining the number of metal storage containers to be allowed, the Director shall consider the following factors:

- (1) The overall site placement;**
- (2) The screening that will be provided;**
- (3) The square footage of the store or building;**
- (4) The square footage of the parcel;**
- (5) The adjacency to residential zoning districts;**
- (6) The period of use; and**
- (7) Any information provided by an applicant explaining the need for extra on-site storage.**

3. A metal storage container may be used as an accessory structure on single-family residential lots that are 1 acre or more in size if the container is not located within any required setbacks and it is painted in a manner that blends in with the primary structure or in an earth tone to minimize the visual impact of the container.

SECTION XXXX:

That Title 18 Appendix (CARSON CITY DEVELOPMENT STANDARDS), Division 1 (LAND USE AND SITE DESIGN), Section 1.105 (Extended use of storage container or metal storage container during declared state of emergency) is hereby repealed (**bold, underlined** text is added, [~~stricken~~] text is deleted) as follows:

~~**1.105 Extended use of storage container or metal storage container during declared state of emergency. [Effective until the date upon which the Declaration of Emergency for COVID-19, issued by the Governor on March 12, 2020, expires.]**~~

- ~~1. Notwithstanding any other provision of CCMC limiting the period during which a storage container or metal storage container may be located in a commercial use district, a person may apply for the extended use of such a container by filing with the Director an application on a form prescribed by the Department.~~
- ~~2. The Director:
 - a. Shall, as soon as reasonably practicable after receiving an application filed in accordance with subsection 1, approve or deny it and notify the person who filed the application of the approval or denial; and
 - b. Shall not charge a fee to review or issue a decision on an application.~~
- ~~3. The approval or denial of an application pursuant to this section is at the sole discretion of the Director and may not be appealed.~~

4. ~~A storage container or metal storage container that is approved for an extended use in accordance with this section must be removed not later than 90 days after the date on which the extended use expires.~~
5. ~~As used in this section:~~
 - a. ~~"Storage container" has the meaning ascribed to it in CCMC 18.03.005.~~
 - b. ~~"Metal storage container" has the meaning ascribed to it in CCMC 18.03.005.]~~

SECTION XXXX:

That Title 18 Appendix (CARSON CITY DEVELOPMENT STANDARDS), Division 1 (LAND USE AND SITE DESIGN), Section 1.11 (Street vendors) is hereby amended (**bold, underlined** text is added, ~~[stricken]~~ text is deleted) as follows:

1.11 Street vendors.

The following minimum standards ~~[shall]~~ apply to all requests for ~~a~~ street vendor ~~[permits.]~~ **permit:**

1. ~~[Street vendors shall]~~ **The permit may only** be approved ~~[at]~~ **for** a specific, permanent location.
2. ~~[Carts]~~ **Any cart that is** used for street vending ~~[shall]~~ **must** be on wheels ~~[and the carts shall]~~ **A street vendor cart must** not be larger **in size** than 3 feet by 5 feet.
3. Only consumable products may be sold from a street vendor cart.
4. If located within a ~~[city]~~ **City** or state right-of-way, **an** encroachment ~~[permits]~~ **permit** and liability insurance ~~[shall be]~~ **in an amount deemed appropriate by the City is** required.
5. If **a street vendor cart is proposed to be located** adjacent to or in front of a business **that is** not ~~[their own,]~~ **owned by** the street vendor cart operator ~~[shall be responsible for obtaining]~~ **, the street cart operator must obtain written** permission ~~[of the affected]~~ **from the owner of that** business and property ~~[owner and shall submit written evidence of such permission.]~~ **, a copy of which must be submitted to the Department with the request for a permit.**
6. If **a street vendor cart is proposed to be located** adjacent to or in front of a property ~~[listed in the Carson City]~~ **within the** historic ~~[district, review, approval and compliance with conditions of the HRC shall be required.]~~ **district, the street vendor cart operator is subject to any applicable requirements relating to the historic district, including, without limitation, review by the Historic Resources Commission.**
7. ~~[Electrical and gas services require review and approval of the building department and the fire marshal.]~~ **If a street vendor cart uses electrical or gas services, the request**

for a permit must be reviewed and approved by the Building Division of the Department and the Carson City Fire Marshal.

8. ~~[Approval of the health department is required for all food vendors.]~~ **All street vendor carts must be approved by the Department of Health and Human Services.**
9. ~~[Other conditions deemed appropriate by the commission or redevelopment advisory citizens committee, as applicable, may be required to mitigate any adverse impacts to adjoining properties and pedestrians.]~~ **A request for a food vendor permit may be subject to any other condition or review by an appropriate public body as deemed necessary by the Director or as required by state or federal law or any regulations adopted thereto.**

SECTION XXXX:

That Title 18 Appendix (CARSON CITY DEVELOPMENT STANDARDS), Division 1 (LAND USE AND SITE DESIGN), Section 1.12 (Outside storage) is hereby amended (**bold, underlined** text is added, ~~[stricken]~~ text is deleted) as follows:

1.12 Outside storage.

The standards set forth in this section apply to outside storage on any property located within a non-residential zoning district where outside storage is a permitted, accessory or conditional use.

Outside storage ~~[requires the following:]~~ **is subject to the following limitations:**

1. Storage areas ~~[shall]~~ **must** be enclosed by a ~~[one hundred percent (100%)]~~ **100 percent** sight obscuring fence or wall **that is** permanently installed and maintained ~~[by]~~ **at** a minimum height of ~~[six (6) feet. No materials and/or equipment shall be stored therein to a height exceeding that of the wall or fence.]~~ **6 feet.**
2. ~~[Storage areas]~~ **A storage are that is** allowed as an accessory use in a commercial **zoning district** or **in the** Limited Industrial (**LI**) zoning district ~~[shall]~~ **may** not occupy more than ~~[twenty percent (20%)]~~ **20 percent** of the lot area unless a ~~[Special Use Permit is first obtained]~~ **special use permit has been issued for the storage area.**
3. Storage areas ~~[shall]~~ **may** not be located ~~[within]~~ **in** any required yard setback, ~~[or parking areas nor shall they be]~~ **or parking area or otherwise** located in any way ~~[which]~~ **that** interferes with normal traffic flow onto, within or from the lot, or **in a manner** which impedes sight distance at ~~[intersections, or which]~~ **intersections or** otherwise impedes driver visibility. ~~[In the case of gasoline service stations, storage areas shall not be permitted]~~ **Storage areas are prohibited** in the setback distance applicable to pump ~~[islands.]~~ **islands at any gasoline service station.**
4. Outside storage is prohibited as a primary permitted use in the ~~[RC and GC]~~ **Retail Commercial (RC) and General Commercial (GC) zoning** districts.

5. Storage containers [~~or~~] **and** other similar enclosures are allowed in the [~~LI, GI and AIP~~] **Limited Industrial (LI), General Industrial (GI) and Air Industrial Park (AIP) zoning** districts, subject to approval [~~of~~] **by** the Director. [~~The storage containers themselves shall~~] **Storage containers must** be screened from view from a public right-of-way by a [~~one hundred percent (100%)~~] **100 percent** site obscuring fence or wall [~~six (6) feet in height (minimum).~~] **that has a minimum height of 6 feet.**

SECTION XXXX:

That Title 18 Appendix (CARSON CITY DEVELOPMENT STANDARDS), Division 1 (LAND USE AND SITE DESIGN), Section 1.13 (Fences, walls and hedges) is hereby amended (**bold, underlined** text is added, [~~stricken~~] text is deleted) as follows:

1.13 Fences, walls and hedges.

The following standards apply to properties located in all zoning districts:

1. Fences, walls and hedges are a permitted use in all districts [~~so long as such~~] **if the** uses are consistent with **the** health, safety and welfare of the community and in compliance with [~~following regulations as outlined in this section. All retaining walls 4 feet or taller shall require a building permit. All block or masonry walls/fences 4 feet or taller shall require a building permit.~~] **the standards set forth in this section.**
2. All fences and walls [~~shall meet~~] **must satisfy** the **applicable** requirements [~~of~~] **set forth in** the **International** Building Code and **International** Fire Code , as currently adopted by Carson City.
3. [~~Electrically charged or barbed~~] **Barbed** fences are a permitted accessory use in [~~CR, A, MH1A, SF5A, SF2A and SF1A~~] districts. Such] **the Conservation Reserve (CR), Agricultural (A), Mobile Home 1 Acre (MH1A), Single-Family 5 Acre (SF5A), Single-Family 2 Acre (SF2A) and Single-Family 1 Acre (SF1A) zoning districts. Barbed** fences are a permitted accessory use in all other [~~use~~] **zoning** districts only with the prior written approval of the [~~director or his designee.~~] **Director.**
4. The height of a fence, wall or hedge [~~shall~~] **must** be measured from the highest adjacent ground, either natural or filled, upon which it is [~~located, except within 15 feet of any front property line or within 30 feet of any street intersection, wherein all base measurements shall be considered from an extension of street grade.~~] **located.**
5. A fence, wall or hedge not exceeding 6 feet in height may be located within any yard except as follows:
 - a. [~~No fences, walls or hedges exceeding~~] **Fences, walls and hedges that exceed** 4 feet in height [~~shall be permitted within~~] **are prohibited in** a front yard setback or within 5 feet of the property line on the street side. [~~When such~~] **If a** fence is constructed of a sight-obscuring material, it [~~shall~~] **must** not exceed 3 feet in height; [~~and~~]

- b. A ~~[maximum 5 foot tall]~~ split rail fence **at a maximum height of 5 feet and installed** within ~~[SF5A, SF2A, SF1A and MH1A]~~ **the Mobile Home 1 Acre (MH1A), Single-Family 5 Acre (SF5A), Single-Family 2 Acre (SF2A) and Single-Family 1 Acre (SF1A) zoning** districts are not restricted by this section and may be located along or within the front yard or street side yard property line or setback; ~~[and]~~
- c. ~~[No fences, walls or hedges exceeding 3 feet in height,]~~ **A fence, wall or hedge that exceeds 3 feet in height or** which ~~[obstruct]~~ **obstructs** vision to any significant ~~[degree, shall be permitted]~~ **degree is prohibited** within **any** sight distance ~~[areas as defined in Section 18.03 (Definitions);]~~ **sight distance area, as that term is defined in CCMC 18.01.573.**
- ~~[d.]~~ For the purposes of this ~~[section only,]~~ **subsection,** picket fences, tight-railed fences, chain-link fences with ~~[slats, or]~~ **with slat and** wire fences with ~~[slats, are considered to be]~~ **slats are deemed** sight-obscuring.
6. The height of fences, walls or hedges, which in no way encroach upon setback requirements and conform with the **International** Building Code as currently adopted by Carson City, ~~[shall]~~ **must** be governed by building height restrictions for each ~~[use]~~ **zoning** district.
7. Fences within setbacks may be permitted in excess of ~~[ordinance requirements by]~~ **height limitations by the** approval of a special use permit.
8. ~~[6 foot]~~ **Six-foot** high fences on flag lots may be located on the property line on all sides, except **that** portions of the parcel fronting on a public street must maintain a ~~[10 foot]~~ **10-foot** setback for fences over 4 feet ~~[tall.]~~ **in height.**
9. Driveway lots must maintain a sight distance area, as **that terms is** defined in ~~[Section 18.03 (Definitions)]~~ **CCMC 18.01.573,** measured from the property line intersection adjacent to the ~~[neighbor's]~~ **neighboring** driveway measuring a distance of 10 feet along both the common property line and along the street.
10. Where property lines may be in the center of the road, the boundary line for **the** purpose of measuring setbacks ~~[are]~~ **must be** measured 30 feet from the centerline of the road with **a** sight distance area ~~[requirements met in accord with Section 18.03 (Definitions).]~~ **, as that term is defined in CCMC 18.01.573.**
11. ~~[When this title]~~ **If any provision of this Title 18 Appendix** requires open storage to be screened by a fence or wall, **it is hereby declared that** the intent **of that provision** is to require items such as stacked materials to be screened, but not to require large equipment over 6 feet in height to be obscured by a fence or wall.

SECTION XXXX:

That Title 18 Appendix (CARSON CITY DEVELOPMENT STANDARDS), Division 1 (LAND USE AND SITE DESIGN), Section 1.14 (Cornices, porches and projections into setbacks) is hereby amended (**bold, underlined** text is added, ~~[stricken]~~ text is deleted) as follows:

1.14 ~~[Cornices, porches and projections into setbacks.]~~ Permissible encroachments.

1. ~~[Cornices,]~~ **Generators, decks and heating, ventilation or air-conditioning units that are not greater than 30 inches in height, and cornices,** eaves, canopies, fireplaces, ~~[decks [thirty (30) inches high or less,] bay windows and similar architectural [features, but not including] features except for~~ flat walls, may extend into any required setback a distance not to exceed ~~[two (2)]~~ **2** feet.
2. Uncovered porches may project not more than ~~[three (3)]~~ **3** feet into any required side yard setback, and not more than ~~[six (6)]~~ **6** feet into any required front or rear yard setback. Unenclosed covered porches with decks ~~[thirty (30)]~~ **30** inches high or less may project into the front yard setback ~~[no] not~~ more than eight ~~[(8) feet provided]~~ **8 feet if** they are ~~[no] not~~ less than ~~[five (5)]~~ **5** feet from a front or street side property ~~[line;] line~~ and do not impede ~~the~~ sight distance ~~[area. All construction must comply with the Building Code currently adopted by Carson City.]~~ **area, as that term is defined in CCMC 18.01.573.**
3. Landing places, outside stairways, railings and guardrails may project not more than ~~[three (3)]~~ **3** feet into any required front, side, street side or rear yard setback. Eaves over the encroaching landing places, outside stairways, railings or guardrails may extend, only over areas of encroachment, up to a maximum of ~~[three (3)]~~ **3** feet into any required front, side, street side or rear yard setback.

SECTION XXXX:

That Title 18 Appendix (CARSON CITY DEVELOPMENT STANDARDS), Division 1 (LAND USE AND SITE DESIGN), Section 1.15 (Manufactured home installation within a single family zoning district) is hereby amended (**bold, underlined** text is added, ~~[stricken]~~ text is deleted) as follows:

1.15 Manufactured home installation within a ~~[single-family] single-family zoning district.~~

The ~~[following standards shall be used in the review of and the]~~ **standards set forth in this section apply to the review and** placement of ~~[a manufactured home in a single-family]~~ **manufactured homes in any single-family** zoning district.

1. ~~[The] A~~ manufactured home ~~[shall] must~~ be **built in accordance with the Manufactured Home Construction and Safety Standards of the U.S. Department of Housing and Urban Development, also known as the HUD Code, and be** permanently affixed to a residential lot and converted to real ~~[property.] property in accordance with state law.~~ A foundation permit is required. Foundations ~~[are to] must~~ be designed by ~~[a Nevada-licensed] an~~ engineer **licensed in this state** to ~~[meet Carson City's requirements] satisfy all applicable criteria~~ for wind, snow and seismic ~~[zone.] zone factors as may be required by the City.~~
2. ~~[The manufactured home shall be manufactured within 5 years immediately preceding the date on which it is affixed to the single family zoned residential lot.]~~

3. ~~The owner/owner's agent shall provide written and photographic documentation that the manufactured home shall have:~~
 - a. ~~Siding which is similar in color, material and appearance to the exterior siding primarily used on other single family residential dwellings in the immediate vicinity of the proposed location of the manufactured home.~~
 - b. ~~Roof pitch/slope, eaves and roof covering which is consistent with those roofs primarily used on other single family residential dwellings in the immediate vicinity of the proposed location of the manufactured home.~~
 - c. ~~Foundation that is masked architecturally with materials primarily used on other single family residential dwellings in the immediate vicinity of the proposed location of the manufactured home.~~
4. ~~For the purpose of this chapter, the term "primarily" shall mean "51 percent" and the term "immediate vicinity" shall mean "within 300 feet" of the subject parcel, excluding commercial, multi-family and industrial development.~~
5. ~~The manufactured home shall consist of more than 1 section.~~
6. ~~The manufactured home shall consist of at least 1,200 square feet of living area.~~
7. ~~The owner/owner's agent shall~~ **The owner of a manufactured home must** provide **to the Department** written documentation that the ~~[subject]~~ **site on which the manufactured home is proposed to be affixed** is not located within:
 - a. An "A" flood zone.
 - b. The historic district ~~;~~ [as recognized by Carson City pursuant to NRS 384.005 and NRS 384.100]
- [8.] **3.** The placement ~~[complies]~~ **of a manufactured home must comply** with all covenants, conditions and restrictions ~~[(CC&R's)]~~ of the subdivision where the manufactured home is proposed to be placed. The ~~[owner/owner's agent shall]~~ **owner of the manufactured home must** provide **to the Department** a copy of the ~~[CC&R's]~~ **covenants, conditions and restrictions** or **, in the absence of such covenants, conditions and restrictions,** written documentation of ~~[the non-existence of CC&R's within the subject area.]~~ **their nonexistence.**
- [9.] ~~If there are no single family residential dwelling units in the immediate vicinity, a minimum 4:12 roof pitch/slope is required and a minimum eave length of 12 inches is required.~~

**CARSON CITY
RESIDENTIAL DISTRICT INTENSITY AND DIMENSION STANDARDS**

Site Development Standards

Zoning Districts	Minimum Parcel Area	Maximum Density	Minimum Lot Width (Feet)	Maximum Lot Depth (Feet)	Maximum Height (Feet)	Minimum Setbacks (Feet) Front	Minimum Setbacks (Feet) Side	Minimum Setbacks (Feet)	Minimum Setbacks (Feet) Rear

	(Acres or Sq. Ft.)							Street Side	
SF5A ⁽⁴⁾	5 AC	1 per 5 AC parcel	200 ⁽⁹⁾	N/A	40 [*]	100	50	50	50
SF2A ⁽⁴⁾	2 AC	1 per 2 AC parcel	200 ⁽⁹⁾	N/A	32 [*]	50	20	20	30
SF1A ⁽⁴⁾	1 AC	1 per 1 AC	120 ⁽⁹⁾	360 ⁽⁷⁾	32 [*]	30	15	20	30
SF21 ⁽⁴⁾	21,000 SF	1 per 21,000 SF parcel	80 ⁽⁹⁾	240 ⁽⁷⁾	26 [*]	20	10	15	20
SF12 ⁽⁴⁾	12,000 SF	1 per 12,000 SF parcel	70 ⁽⁹⁾	210 ⁽⁷⁾	26 [*]	20	10	15	20
SF6 ⁽⁴⁾	6,000 SF 6,500 SF Corner	1 per 6,000 SF parcel/ 6,500 SF corner parcel	60 ⁽⁹⁾	180 ⁽⁷⁾ (120 cul-de-sac)	26 [*]	20 ⁽²⁾	5 ⁽²⁾	10	10 ⁽³⁾
MH6 ⁽⁴⁾	6,000 SF 6,500 SF Corner	1 per 6,000 SF parcel	60 ⁽⁹⁾	180 ⁽⁷⁾	26 [*]	20	5	10	10 ⁽³⁾
MH12 ⁽⁴⁾	12,000 SF	1 per 12,000 SF parcel	70 ⁽⁹⁾	210 ⁽⁷⁾	26 [*]	20	10	15	20
MH1A ⁽⁴⁾	1 AC	1 per acre	120 ⁽⁹⁾	360 ⁽⁷⁾	32 [*]	30	15	20	30
MFD	6,000 SF	1 or 2 per 6,000 SF parcel	60 ⁽⁹⁾	150	26 [*]	20	5 ⁽⁴⁾	10	10 ⁽³⁾
MHFA ⁽⁸⁾	6,000 SF	29-36; 1,200 SF of land area/1 bedroom units or studios and/or 1,500 SF of land area/2 bedroom or more units	60 ⁽⁹⁾	150	45 [*]	20	10 ⁽⁴⁾⁽⁵⁾	15	20 ⁽⁵⁾
MHP	1 AC	N/A	N/A	N/A	N/A	10 ⁽⁶⁾	10 ⁽⁶⁾	10 ⁽⁶⁾	10 ⁽⁶⁾
RO ⁽⁴⁾	6,000 SF	7.26	60 ⁽⁹⁾	150	35 [*]	20	10	15	20

Additional Requirements or Allowances:

* Additional height allowed by Special Use Permit.

- (1) Only 1 main building or home is allowed per 1 parcel.
- (2) Varied setbacks are permitted in accordance with Division 1.17 of the development standards.
- (3) All portions of a structure exceeding 20 feet in height must be a minimum of 20 feet from the rear property line.
- (4) Side setback may be waived if 2 adjacent structures are subject to the latest adopted edition of the Uniform Building Code.
- (5) For each story above 1 story, add 10 feet if adjacent to a single family district.
- (6) Park perimeter only; see Division 10 of the development standards for interior space/setback requirements.
- (7) Maximum lot depth is 3 times the minimum lot width except as necessary to meet minimum parcel size.
- (8) Open Space. Each parcel of land must contain a single, continuous tract of land designated as an open area of not less than 150 square feet per dwelling unit, reserved exclusively for the common recreational use of the tenants on such parcel. 50 percent of the required common open space shall be softscape as listed in definitions. Only 25 percent of the total required open space requirement may be within an enclosed recreation facility. The required open space must not be contained within any of the required front yard or side yard setback abutting a street. In addition, there must be an open space area at least 100 square feet in size either contiguous to each dwelling unit for the exclusive use of the resident of that dwelling unit, or that space added to the requirements of this section.
- (9) 54 feet minimum street frontage at the end of a cul de sac.

**CARSON CITY
NON-RESIDENTIAL DISTRICT INTENSITY AND DIMENSION STANDARDS**

Site Development Standards

Zoning Districts	Minimum Area (SF or AC)	Minimum Lot Width (Feet)	Maximum Lot Depth (Feet)	Maximum Height (Feet)	Minimum Setbacks (Feet) Front	Minimum Setbacks (Feet) Side	Minimum Setbacks (Feet) Street Side	Minimum Setbacks (Feet) Rear
RO	6,000 SF ⁴	60 ¹²	150	35 ¹	20 ⁸	10 ⁵	15 ^{5,8}	20 ⁸
GO	6,000 SF ⁴	60	150	50 ¹	15 ⁸	10	10 ⁸	20 ^{6,8}
NB	9,000 SF ⁴	75	N/A	26 ¹	0 ^{7,8}	0 ⁷	0 ^{7,8}	0 ^{7,8}
RC	6,000 SF ⁴	50	N/A	45 ¹	0 ^{7,8}	0 ⁷	0 ^{7,8}	0 ^{7,8}
GC	6,000 SF	60	N/A	45 ¹	0 ^{7,8}	0 ⁷	0 ^{7,8}	0 ^{7,8}
TC	6,000 SF	60	N/A	45 ¹	0 ⁸	0 ⁷	0 ⁸	0 ⁸
DC	6,000 SF	50	N/A	45 ^{1,2}	0 ^{8,9}	0 ⁹	0 ^{8,9}	0 ^{8,9}
LI	21,000 ¹	100	N/A	32 ¹	30 ^{8,10}	10 ^{10,11}	10 ^{8,10}	30 ^{8,10,11}
GI	12,000 SF ⁴	120	N/A	45 ¹	30 ^{8,10}	0 ¹⁰	0 ^{8,10}	0 ^{8,10}
AIP	20,000 SF	100	N/A	45 ¹	30 ⁸	20	20 ⁸	30 ⁸
CR	20 AC	300	N/A	40 ¹	30	20	20	30
A	20 AC	300	N/A	40 ¹	30	20	20	30
P	N/A ³	N/A ³	N/A ³	N/A ³	N/A ³	N/A ³	N/A ³	N/A ³

PN/PC/PR	N/A ³	N/A ³	N/A ³	N/A ³	N/A ³	N/A ³	N/A ³	N/A ³
----------	------------------	------------------	------------------	------------------	------------------	------------------	------------------	------------------

Additional Requirements or Allowances:

1. ~~Additional height allowed by special use permit.~~
2. ~~In accordance with the restrictions outlined in the downtown master plan element for building heights of structures located within 500 feet of the State Capital.~~
3. ~~Building height, building setbacks, minimum area, minimum lot width, and maximum lot depth to be determined by special use permit.~~
4. ~~For each main structure.~~
5. ~~Side setback may be waived if 2 adjacent structures are connected by a parapet fire wall.~~
6. ~~Rear yard shall be increased by 10 feet for each story above 2 stories. Where the rear yard abuts a commercial district, the setback is zero feet.~~
7. ~~Adjacent to Residential District, 30 feet is required. Corner lots require setback for sight distance.~~
8. ~~Business Arterial landscape setback requirement = 10 feet (average).~~
9. ~~Adjacent to Residential District, 10 feet required. Corner lots require setback for sight distance.~~
10. ~~50 feet adjacent to Residential District.~~
11. ~~If Adjacent to Limited Industrial (LI) District, the side and rear yard setbacks may be reduced to zero subject to applicable building and fire codes.~~
12. ~~54 feet minimum street frontage at the end of a cul de sac.~~
13. ~~Except in the CR, A, P, PN, PC and PR zoning districts, minimum area includes all common areas, parking, landscaping and building areas associated with a project for the purposes of creating building envelopes or condominium units where common access is provided to the project site.]~~

SECTION XXXX:

That Title 18 Appendix (CARSON CITY DEVELOPMENT STANDARDS), Division 1 (LAND USE AND SITE DESIGN), Section 1.16 (Youth recreation facilities performance standards) is hereby amended (**bold, underlined** text is added, [~~stricken~~] text is deleted) as follows:

1.16 Youth recreation facilities performance standards.

[~~The following~~] **In addition to any other applicable standard set forth in this Title 18 Appendix, the performance standards [shall be considered in] set forth in this section apply to and must be considered during the** review of individual special use permit requests for youth recreation facilities [~~with~~] **located in** residential zoning districts, [~~in addition to other development standards.~~]

1. Design and Development Standards.
 - a. Lot size [~~shall~~] **must** be a minimum of 3 acres.

- b. [~~Youth recreation facilities within~~] **Facilities in a** residential zoning district [~~shall~~] **must** be located a minimum of one mile from other facilities or separated by Highway 395, Highway [~~50,~~] **50** or the freeway right-of-way.
 - c. [~~A facility for youth recreation~~] **Facilities** should be designed to enhance the character of the surrounding neighborhood.
 - d. The availability of public facilities, services and [~~utilities.~~] **utilities must be considered.**
 - e. [~~The pedestrian, bicycle,~~] **Pedestrian, bicycle** and motor vehicle traffic generated by the facility and how [~~it~~] **the traffic** relates to the existing circulation plans [~~shall~~] **must** be considered. Circulation patterns and [~~pick-up/drop-off~~] **pick-up and drop-off** areas for users of the [~~facilities shall~~] **facility must** be designed to minimize negative impacts to surrounding properties while providing safe and convenient pedestrian, [~~bicycle,~~] **bicycle** and vehicular traffic movements and access to the site.
 - f. Landscaping should be designed to enhance the character of the surrounding area and [~~shall~~] **must** include deciduous trees and a variety of decorative plantings and shrubs.
 - g. Lighting [~~shall~~] **must** be designed with residential character and [~~shall~~] **must** be shielded to eliminate glare onto adjoining properties.
 - h. All structures [~~shall~~] **must** meet a minimum setback of 50 feet from adjacent residential property lines. Active outdoor recreation use areas [~~such as~~] , **including, without limitation,** ball fields, [~~courts,~~] **courts** and play equipment [~~shall be setback~~] , **must be set back** a minimum of 25 feet from adjacent residential properties.
 - i. Fencing [~~and/or screening shall~~] **and screening must** be located along the perimeter of the site abutting residential properties. [~~Fencing/screening~~] **Fencing and screening** should be sufficient to minimize noise and visual impacts to adjacent properties.
 - j. Loading and unloading areas [~~shall~~] **must** be located at or near the rear of the building and away from [~~and/or~~] **or** screened from adjacent streets and abutting residential properties.
2. Operational and Program Standards.
- a. Programs designed for the users may include [~~but not be limited to~~] , **without limitation,** leadership programs, education and career guidance, health and life skills, arts, sports, fitness, recreation and specialized programs.
 - b. Programs should be scheduled at times [~~that~~] **when** noise will not be a problem for surrounding areas.
 - c. Hours of operation [~~shall~~] **must** be such that indoor activities and programs are completed **by** 10:00 p.m. **on** weekdays and **by** 11:00 p.m. **on** weekends. Outdoor activities [~~shall~~] **must** be completed by 9:00 p.m. **on** weekdays and **by** 10:00 p.m. on weekends.

- d. ~~[The facility shall have]~~ **A facility must provide** a minimum of [~~±~~] **one** instructor, with appropriate training, [~~per~~] **for every** 20 youth.

SECTION XXXX:

That Title 18 Appendix (CARSON CITY DEVELOPMENT STANDARDS), Division 1 (LAND USE AND SITE DESIGN), Section 1.17 (Multi-family apartment (MFA) development standards) is hereby amended (**bold, underlined** text is added, [~~stricken~~] text is deleted) as follows:

1.17 Multi-family apartment (MFA) development standards.

The [~~following standards~~] **provisions set forth in this section** are intended to establish minimum standards for residential development **located** within the Multi-Family Apartment (MFA) zoning district.

1. Maximum permitted density:
 - a. For one-bedroom or studio units, one (1) unit per one thousand two hundred (1,200) square feet of area.
 - b. For two (2) or more bedroom units, one (1) unit per one thousand five hundred (1,500) square feet of area.
2. Maximum building height: Forty-five (45) feet.
3. Setbacks:
 - a. Front yard: Ten (10) feet, plus an additional ten (10) feet for each story above two (2) stories; minimum driveway approach from property line to garage doors is twenty (20) feet.
 - b. Side yard: Ten (10) feet for external project boundaries; minimum ten (10) feet between residential structures for internal setbacks. Where a side yard is adjacent to a single-family zoning district, an additional ten (10) feet is required for each story above one (1) story.
 - c. Street side yard: Ten (10) feet, plus an additional five (5) feet for each story above two (2) stories; minimum driveway approach from property line to garage doors is twenty (20) feet.
 - d. Rear yard: Twenty (20) feet. Where a rear yard is adjacent to a single-family zoning district, an additional ten (10) feet is required for each story above one (1) story.
4. Required parking: Two (2) spaces per dwelling unit; and in compliance with the Development Standards Division 2, Parking and Loading.
5. Open Space:

- a. For Multi-Family Residential development, a minimum of 150 square feet per dwelling unit of common open space must be provided. For projects of 10 or more units, areas of common open space may only include contiguous landscaped areas with no dimension less than 15 feet, and a minimum of 100 square feet per unit of the common open space area must be designed for recreation, which may include but not be limited to picnic areas, sports courts, a softscape surface covered with turf, sand or similar materials acceptable for use by young children, including play equipment and trees, with no dimension less than 25 feet.
 - b. For Multi-Family Residential development, a minimum of 100 square feet of additional open space must be provided for each unit either as private open space or common open space.
 - c. For Single-Family Residential development or Two-Family Residential development, a minimum of 250 square feet of open space must be provided for each unit either as private open space or common open space.
 - d. Front and street side yard setback areas may not be included toward meeting the open space requirements.
6. Landscaping. Landscaping shall comply with the Development Standards Division 3, Landscaping.

SECTION XXXX:

That Title 18 Appendix (CARSON CITY DEVELOPMENT STANDARDS), Division 1 (LAND USE AND SITE DESIGN), Section 1.18 (Residential development standards in non-residential districts) is hereby amended (**bold, underlined** text is added, ~~stricken~~ text is deleted) as follows:

1.18 Residential development standards in non-residential districts.

The ~~following standards~~ **provisions set forth in this section** are intended to establish minimum standards and ~~Special Use Permit~~ **special use permit** review criteria for residential development within the Neighborhood Business (NB), Retail Commercial (RC), General Commercial (GC), Residential Office (RO) and General Office (GO) zoning districts.

1. Permitted uses. Residential uses are only allowed as permitted by Chapter 18.04, Use Districts, as a primary or conditional use in the applicable zoning districts.
2. Maximum permitted density. There is no maximum residential density within non-residential zoning districts subject to meeting the height, setback, parking and open space requirements of this chapter. **For the purpose of allowing flexibility in design, minimum lot size does not apply.**
3. Maximum building height shall be the maximum height established by the zoning district in which the project is located.

4. Setbacks. Minimum setbacks shall be those established by the zoning district in which the project is located, subject to the following:
 - a. In the NB, RC, GC and GO zoning districts, a minimum setback of [~~twenty (20)~~] **30** feet is required adjacent to a residential zoning district, with an additional ten (10) feet for each story above one (1) story if adjacent to a single-family zoning district.
 - b. A minimum setback of ten (10) feet is required from the right-of-way of an arterial street as identified in the adopted Transportation Master Plan, excluding the Downtown Mixed-Use area.
5. Required parking: Two (2) spaces per dwelling unit; and in compliance with the Development Standards Division 2, Parking and Loading.
6. Open Space.
 - a. For Multi-Family Residential development, a minimum of 150 square feet per dwelling unit of common open space must be provided. For projects of 10 or more units, areas of common open space may only include contiguous landscaped areas with no dimension less than 15 feet, and a minimum of 100 square feet per unit of the common open space area must be designed for recreation, which may include but not be limited to picnic areas, sports courts, a softscape surface covered with turf, sand or similar materials acceptable for use by young children, including play equipment and trees, with no dimension less than 25 feet.
 - b. For Multi-Family Residential development, a minimum of 100 square feet of additional open space must be provided for each unit either as private open space or common open space.
 - c. For Single-Family Residential development or Two-Family Residential development, a minimum of 250 square feet of open space must be provided for each unit either as private open space or common open space.
 - d. Front and street side yard setback areas may not be included toward meeting the open space requirements.
7. Landscaping. Landscaping shall comply with the Carson City Development Standards Division 3, Landscaping.
8. Special Use Permit review standards. Where a residential use is a conditional use within a given zoning district, the Planning Commission shall make two (2) of the following findings in the affirmative in the review of the Special Use Permit in addition to the required findings of Section 18.02.080 of the Carson City Municipal Code.
 - a. The development is not situated on a primary commercial arterial street frontage.
 - b. The development is integrated into a mixed-use development that includes commercial development
 - c. The applicant has provided evidence that the site is not a viable location for commercial uses.

- d. The site is designated Mixed-Use Commercial, Mixed-Use Residential or Mixed-Use Employment on the Master Plan Land Use Map and the project meets all applicable mixed-use criteria and standards.

SECTION XXXX:

That Title 18 Appendix (CARSON CITY DEVELOPMENT STANDARDS), Division 1 (LAND USE AND SITE DESIGN), Section 1.19 (Adult merchandise retail establishment performance standards) is hereby amended (**bold, underlined** text is added, ~~stricken~~ text is deleted) as follows:

1.19 Adult merchandise retail establishment performance standards.

[The] **An adult merchandise retail establishment must satisfy each of the** following performance standards [~~are mandatory requirements in the review of business licenses for Adult Merchandise Retail Establishments.~~] **to be approved for a business license:**

1. The floor area devoted to material defined in "Adult Merchandise Retail Establishment" does not exceed up to five percent (5%) of the total display or retail floor area of the business or two hundred (200) square feet, whichever is less;
2. The material is available only for sale or lease for private use by the purchaser or lessee off the premises of the business;
3. The floor area devoted to material as defined in "Adult Merchandise Retail Establishment" is segregated by partition, separate entrance or otherwise obscured from casual observance by minors;
4. The floor area devoted to material defined in "Adult Merchandise Retail Establishment" is clearly signed to prohibit access to minors;
5. The floor area devoted to material defined in "Adult Merchandise Retail Establishment" is adequately staffed by persons over eighteen (18) years of age to assure monitoring of minors who may seek access to the restricted floor area;
6. The business does not advertise or hold itself out to the public in any way as being an adult merchandise retail establishment, whether by store window displays, signs or other means;
7. The business cannot be combined with any other area or business to result in an increase in the floor area devoted to this activity beyond the maximum specified in (1) above;
8. No product for sale or gift, picture or other graphic representation thereof, shall be displayed so as to be visible from the street or exterior of the building;
9. At the time of the business license request, the applicant shall provide a detailed site plan designating the proposed Adult Merchandise Retail Establishment area, as it relates to the total floor area of the business;

10. Adult Merchandise Retail Establishments established prior to November 7, 2007 which do not comply with the provisions of Division 1.19 Adult Merchandise Retail Establishment shall be deemed non-conforming and may continue to operate as approved by the criteria identified in their approved Carson City Business License.
11. Nonconforming Adult Merchandise Retail Establishments shall not relocate in Carson City unless the establishment comes into full compliance with the current code and development standards.
12. No Adult Merchandise Retail Establishment shall be located within one thousand (1,000) feet of any other Adult Merchandise Retail Establishment or Adult Entertainment Facility.
- ~~[13. Location Criteria. Adult Merchandise Retail Establishments may be located only in Retail Commercial (RC), General Commercial (GC), Limited Industrial (LI), and General Industrial (GI) zoning districts and provided that the business comply with all performance standards.]~~

SECTION XXXX:

That Title 18 Appendix (CARSON CITY DEVELOPMENT STANDARDS), Division 1 (LAND USE AND SITE DESIGN), Section 1.20 (Medical Marijuana Establishments and Marijuana Establishments) is hereby amended (**bold, underlined** text is added, [~~stricken~~] text is deleted) as follows:

1.20 Medical Marijuana Establishments and Marijuana Establishments. [~~(NRS Title 56)~~]

The following standards are intended to establish minimum standards and Special Use Permit review criteria for Medical Marijuana Establishments and Marijuana Establishments, in addition to other standards for commercial and industrial development.

1. The following standards apply to all Medical Marijuana Establishments and Marijuana Establishments:
 - (a) Medical Marijuana Establishments and Marijuana Establishments require the issuance of a Special Use Permit. Special Use Permits for Medical Marijuana Establishments and Marijuana Establishments are only valid at the specific location for which a person has obtained the required approval through the applicable state agency to operate as a Medical Marijuana Establishment or Marijuana Establishment. A Special Use Permit that is issued in accordance with this Division automatically expires and shall be deemed void if the Medical Marijuana Establishment or Marijuana Establishment loses or otherwise forfeits the required state approval to operate. A Special Use Permit issued in accordance with this Division is not transferable between operators and locations within Carson City. Except as otherwise provided in this Division and notwithstanding any other provision of CCMC, a separate Special Use Permit is not required for a Medical Marijuana Establishment or Marijuana Establishment that will be

established in an existing location at which a Medical Marijuana Establishment or Marijuana Establishment in good standing already operates. The expansion of any location of a Medical Marijuana Establishment or Marijuana Establishment that will result in an increase of more than ten (10) percent of the space in which the Medical Marijuana Establishment or Marijuana Establishment has been approved to operate requires the issuance of an amended Special Use Permit.

- (b) The consumption of marijuana products is prohibited on the premises of any Medical Marijuana Establishment and Marijuana Establishment.
- (c) All business activities related to Medical Marijuana Establishments and any marijuana cultivation facility, marijuana testing facility, marijuana product manufacturing facility or retail marijuana store must be conducted indoors and within a permanent building. The use of an office trailer or other temporary structure is prohibited. All Medical Marijuana Establishments and Marijuana Establishments must at all times maintain an interior and exterior appearance that is professional, orderly, dignified and consistent with the traditional style of pharmacies and medical offices.
- (d) The outdoor display or sale of any Medical Marijuana Establishment or Marijuana Establishment merchandise or product is prohibited.
- (e) Accessory outside storage for Medical Marijuana Establishments and Marijuana Establishments must comply with the provisions of Title 18 Appendix (Carson City Development Standards), Division 1.12 (Outside Storage).
- (f) Access to Medical Marijuana Establishment or Marijuana Establishment must comply with all applicable state and federal laws and regulations.
- (g) Medical Marijuana Establishment and Marijuana Establishment merchandise and products must not be visible when viewed from outside the building in which the Marijuana Establishment or Marijuana Establishment is located.
- (h) All signage for Medical Marijuana Establishments and Marijuana establishments must be discreet, professional and consistent with the traditional style of signage for pharmacies and medical offices. All Medical Marijuana establishments and Marijuana Establishments are limited to following signage:
 - (1) A maximum of thirty (30) square feet of wall sign area.
 - (2) A maximum of thirty-two (32) square feet of freestanding sign area.
 - (3) The maximum freestanding sign height for Marijuana Dispensaries and Marijuana Retail Stores shall be determined by the applicable commercial or shopping center regulations of Division 4 (Signs).
 - (4) The maximum freestanding sign height for all Medical Marijuana Establishments and Marijuana Establishments other than Medical Marijuana Dispensaries and Marijuana Retail Stores shall be ten (10) feet.
 - (5) Where a Medical Marijuana Establishment and Marijuana Establishment are jointly located on a single property, the maximum permitted sign area applies to the property and not each type of Establishment.

- (i) Off-street parking must be provided for Medical Marijuana Establishments and Marijuana Establishments in accordance with the following:
 - (1) For Medical Marijuana Dispensaries and Marijuana Retail Stores, a minimum of one (1) space for every three hundred (300) square feet of gross floor area.
 - (2) For Medical Marijuana Cultivation Facilities and Marijuana Cultivation Facilities, a minimum of one (1) space for every one thousand (1,000) square feet of gross floor area.
 - (3) For Medical Marijuana Product Manufacturing Facilities and Marijuana Product Manufacturing Facilities, a minimum of one (1) space for every five hundred (500) square feet of gross floor area.
 - (4) For Medical Marijuana Testing and Marijuana Testing Facilities, a minimum of one (1) space for every four hundred (400) square feet of gross floor area.
 - (j) Notwithstanding any other provision of CCMC, not more than 2 Medical Marijuana Dispensaries and 4 Marijuana Retail Stores are allowed to operate at the same time in Carson City.
 - (k) A Medical Marijuana Dispensary may only be jointly located within the same premises of a Marijuana Retail Store that is operating in good standing.
 - (l) A Medical Marijuana Establishment or Marijuana Establishment is prohibited within one thousand (1,000) feet of a public or private school that provides formal education traditionally associated with preschool or kindergarten through grade twelve (12), or within three hundred (300) feet of a facility that provides day care to children, a public park, a playground, a public swimming pool, and any other center or facility, the primary purpose of which is to provide recreational opportunities or services to children or adolescents, which already exists on the date the application for the proposed Medical Marijuana Establishment or Marijuana Establishment is submitted to the applicable state agency for approval to operate, as measured on a straight line from the property line of the nearest school or facility to the front door or primary entrance of the Medical Marijuana Establishment or Marijuana Establishment.
2. The following standards apply to all Medical Marijuana Dispensaries and Retail Marijuana Stores:
- (a) A single point of secure public entry must be provided and identified.
 - (b) Hours of operation are limited to between 8:00 a.m. and 10:00 p.m., daily.
 - (c) Drive-through service is permitted.
 - (d) A Medical Marijuana Dispensary or Retail Marijuana Store is prohibited on any property, or within a shopping center with frontage, that is located on the same street on which a residentially zoned property is also located unless the dispensary or store is located more than three hundred (300) feet from the residential property, as measured on a straight line from the nearest residential property line abutting the street right-of-way to the front door of the dispensary or store.

- (e) Curbside pickup service may be authorized pursuant to a Special Use Permit. A Special Use Permit that is issued for curbside pickup service must expressly state that such service:
 - (1) Must be provided only through a customer appointment basis.
 - (2) Must be conducted in a manner which does not increase ordinary onsite or offsite vehicle traffic congestion, including, without limitation, an increase in parked or unparked vehicles awaiting curbside pickup service in any area outside the immediate premises of the property on which the Medical Marijuana Dispensary or Retail Marijuana Store is located.
 - (3) Must be provided in an area immediately adjacent to the Medical Marijuana Dispensary or Retail Marijuana Store.
 - (4) Must be provided in an area that is visible on an operable security surveillance system.
 - (5) Must not be provided on any property other than the private property on which the Medical Marijuana Dispensary or Retail Marijuana Store is located.
 - (6) Must not be provided in front of or adjacent to any other business in a manner that is disruptive to the other business.
 - (7) Must not be provided in any designated fire lane.
 - (8) Must not be facilitated through the use of any directional sign or shade structure that contains commercial advertisement for the Medical Marijuana Dispensary or Retail Marijuana Store.
- 3. In addition to the required findings for a Special Use Permit, the following standards must also be considered in the review of a request for a Special Use Permit for a Medical Marijuana Dispensary or Marijuana Retail Store to be located within the General Industrial zoning district:
 - (a) That the proposed Medical Marijuana Dispensary or Marijuana Retail Store is located where sufficient, convenient and safe access is provided to the public.
 - (b) That the proposed location has adequate lighting and street improvements for a use providing public access.

SECTION XXXX:

That Title 18 Appendix (CARSON CITY DEVELOPMENT STANDARDS), Division 1 (LAND USE AND SITE DESIGN), Section 1.21 (Hemp cultivation facilities; general standards; applicability) is hereby amended (**bold, underlined** text is added, [~~stricken~~] text is deleted) as follows:

1.21 Hemp cultivation facilities; general standards; applicability.

1. In addition to meeting any other applicable development standard, a hemp cultivation facility:
 - a. Except as otherwise provided in subsection [2-,] 2, must be located within a permanent building with an exterior appearance that is consistent with the traditional style of other facilities used for manufacturing.
 - b. Must conduct all business activities indoors.
 - c. Must, at all times, be equipped with a functioning system of odor control to completely prevent the detection of hemp odor from any area outside the facility, including, without limitation, any adjacent property or the public right-of-way.
 - d. Except as otherwise provided in subsection [2-,] 2, must not store or display outdoors any hemp or any product or merchandise related to hemp, whether or not such an outdoor display is screened.
 - e. Must not store or display indoors any hemp or any product or merchandise related to hemp in a manner such that the hemp, product or merchandise is visible from the exterior of the building within which the facility is located.
2. A hemp cultivation facility may use outside storage so long as such storage complies with the requirements set forth in [division] **Division** 1.12 of this title.
3. Notwithstanding any other provision of Title 18 of CCMC, a hemp cultivation facility must have not less than one dedicated off-street parking space for each:
 - a. One thousand (1,000) square feet of gross floor area; and
 - (b) Five hundred (500) square feet of gross floor area that is used to handle hemp for processing into commodities, products or agricultural hemp seed.

SECTION XXXX:

That Title 18 Appendix (CARSON CITY DEVELOPMENT STANDARDS), Division 2 (PARKING AND LOADING) is hereby amended by adding thereto a new Section 2.05 (Purpose) (**bold, underlined** text is added, [~~stricken~~] text is deleted) as follows:

2.05 Purpose.

Purpose. The purpose of this Division is to establish parking and loading standards for new and expanded development in the City, protect the health, safety and general welfare of the community, protect property values and enhance the aesthetic appearance of the City, including the visual appearance of City roads and streets. It is hereby declared that the standards set forth in this section are deemed the minimum requirements necessary to further the purpose of this Division and that additional requirements may be implemented as necessary or desirable.

Applicability. The standards set forth in this Division apply to parking and loading in all zoning districts.

SECTION XXXX:

That Title 18 Appendix (CARSON CITY DEVELOPMENT STANDARDS), Division 2 (PARKING AND LOADING), Section 2.1 (Access/Circulation/Parking) is hereby amended (**bold, underlined** text is added, [~~stricken~~] text is deleted) as follows:

2.1 [~~Access/Circulation/Parking.~~] Access; circulation; parking.

- 2.1.1 Site access, parking and internal circulation should be designed in a straight-forward manner to provide convenient, safe and efficient flow of pedestrians, bicycles and vehicles.
- 2.1.2 Ingress and egress to a site should be kept to a minimum to reduce disruption of street traffic flow and reduce conflicts with pedestrians. See also Division 12, Transportation, for location requirements.
- 2.1.3 Joint access between adjacent sites is encouraged.
- 2.1.4 Adequate stacking areas for vehicle traffic shall be provided at site entrances and exits. Drop-off areas [~~shall~~] **should** be provided when appropriate.
- 2.1.5 Parking areas should be aligned to direct pedestrian movement perpendicular to buildings, reducing the need to cross parking aisles and landscape areas.

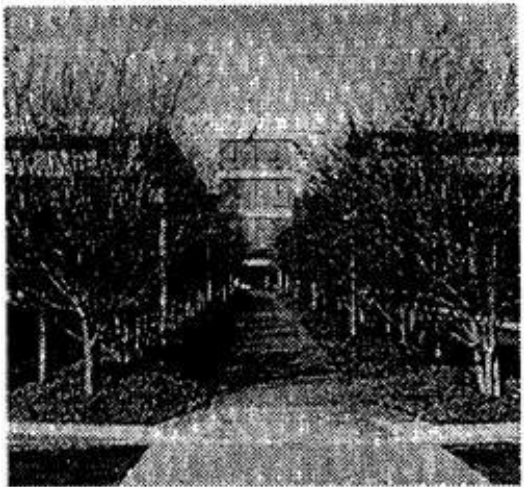

Typical separated pedestrian walkway

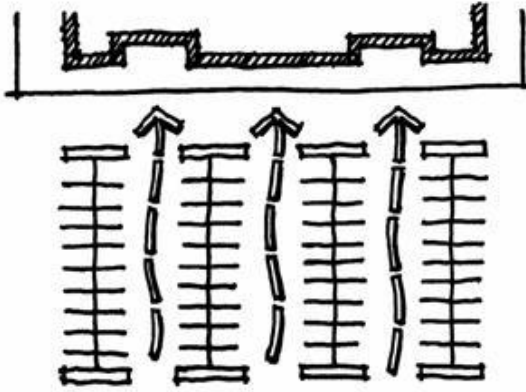

Typical separated pedestrian walkway in parking lot

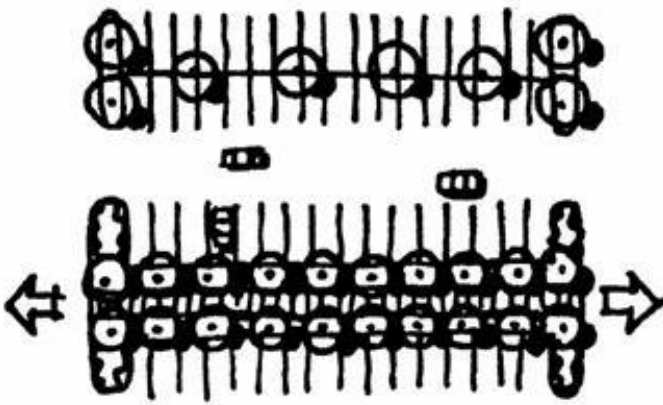

Typical separated pedestrian walkway in parking lot

- 2.1.6 Separated pedestrian walkways are encouraged in large parking lot areas.
- 2.1.7 Provision for bicycles and other modes of transportation such as bus stops or pick-up/drop-off areas should be incorporated into [design of facilities.] **parking lot areas as appropriate.**
- 2.1.8 Parking should be located to the side and rear of a project site where feasible. For projects with large parking demands, parking areas should be separated into a series of smaller parking lots.

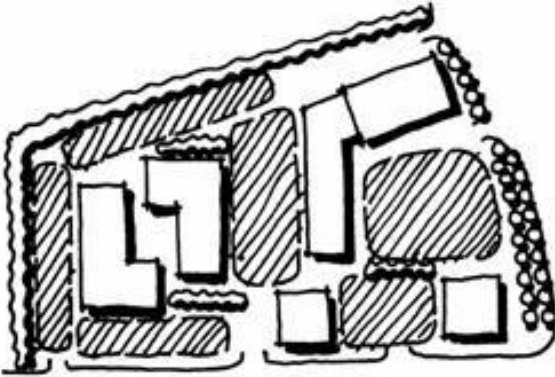

Typical Large Lot Break-up



Typical parking separated by landscape and/or sidewalk.

- 2.1.9 Parking spaces must not directly abut a building and ~~[should]~~ **must** be separated by ~~[foundation]~~ landscape planting beds ~~[and/or]~~ **or** sidewalks. ~~[Parking should not be located directly in front of building entries to avoid impeding pedestrian access.]~~
- 2.1.10 All parking and pedestrian areas **and access ways** must be designed to the most current American With Disabilities Act/American National Standards Institute (ADA/ANSI) standards.
- 2.1.11 Access for service vehicles and emergency vehicles ~~[shall]~~ **must** be provided.
- 2.1.12 Drive-thru windows ~~[shall not front a street. If unavoidable due to site constraints, an Administrative Permit application shall be required to address screening with landscape berms, or other mitigation. Holding/stacking lanes shall be a minimum of eighty (80) feet for drive thru windows.]~~ **must not face directly to a street except as otherwise approved by an administrative permit. Drive-thru areas for vehicle stacking behind the service window must be not less than 80 feet and must be screened from view from the right-of-way through the use of landscape berms or similar means as approved by the Director.**
- 2.1.13 Automobile ~~[repair/service]~~ **repair or service** buildings ~~[shall be oriented so that the]~~ **must be oriented in a manner such that any** bay doors do not front **directly to** a street. **The Director may approve an alternative layout if parcel constraints render impractical the orientation of repair or service doors away from the street frontage.**

- 2.1.14 A safe and convenient area for loading and unloading of passengers ~~[shall]~~ **must** be provided.
- 2.1.15 Sidewalks ~~[shall]~~ **must** be provided along all street frontages except where specifically exempted. Sidewalk linkages to all buildings and uses on the site ~~[shall]~~ **must** be provided. The use of parkways adjacent to streets with a sidewalk setback from the street is encouraged. The use of enhanced paving materials such as pavers, stamped concrete, bricks or similar materials is encouraged.
- 2.1.16 Snow storage ~~[shall]~~ **must** be considered in the design of all parking areas. Snow storage ~~[shall]~~ **must** not be located within landscaping areas except for rock and non-vegetated sites.

SECTION XXXX:

That Title 18 Appendix (CARSON CITY DEVELOPMENT STANDARDS), Division 2 (PARKING AND LOADING), Section 2.2 (Number of spaces required) is hereby amended (**bold, underlined** text is added, ~~[stricken]~~ text is deleted) as follows:

2.2 Number of spaces required.

~~[The]~~ **This section sets forth the** minimum number of off-street parking spaces for each use ~~[is set forth in the following subsections.]~~ . If there are ~~[a number of]~~ **multiple** uses on a single parcel, the parking for each individual use is calculated and the total required is the sum of the separate individual ~~[requirements, except as provided in subsection G of this section.]~~ **uses.** If a garage is counted as required parking, the driveway access to the garage ~~[shall not then]~~ **may not** be counted as ~~[required parking.]~~ **unless approved by a special use permit.** If an accredited source ~~[e.g.]~~ **such as the** Institute of Transportation Engineers ~~[(ITE)]~~ provides an acceptable alternative to a parking ~~[standards]~~ **standard set forth** in this ~~[division, the director]~~ **section, the Director** may consider ~~[an]~~ **the** alternative.

~~[These]~~ **The** parking requirements **set forth in the following provisions** are mandatory for the various buildings and uses irrespective of the zoning districts in which they occur, except as otherwise ~~[noted in this section.]~~ **specifically noted.**

A. Residential Uses.	
All single-family, two family, and multiple family residential dwellings	2 spaces per dwelling [unit.*] <u>In developments where internal or abutting public streets are reduced to less than the standard street width, thereby prohibiting on-street parking, 1 additional off-street parking space per 2 units must be designated and assigned as guest parking within 300 feet of the applicable dwelling, as measured by walking distance from the</u>

	<u>units to which the guest parking spaces are assigned.</u>
Rooming or boarding house, fraternity or other residential group dwelling	1 parking space for each bedroom plus 1 space for each staff member on the largest shift.
[Senior citizen] <u>Age-restricted senior housing developments</u>	1 space per unit plus 1 parking space per 5 units classified and signed as guest parking.
	[* In developments where internal or abutting public streets are reduced to less than the standard street width thereby prohibiting on-street parking, 1 additional off-street parking space per 2 units shall be designated and shall be signed as guest parking within 300 feet, measured by walking distance, of the units which they serve.]
B. Institutional Uses.	
Child care [centers] <u>facilities</u> and preschools	1 space for each employee plus a permanently maintained [loading/unloading] <u>loading or unloading</u> area installed in accordance with engineering standards.
Churches and funeral homes	1 space for each 3 fixed seats or every 10 feet of bench length. Where no permanent seats or benches are maintained, 1 space for every 20 square feet of principal assembly area.
Commercial or business schools	1 space for each 150 square feet of classroom area.
Congregate care housing/senior citizen home	1 space for each 5 beds plus 1 space per 3 employees.
Elementary and junior high schools	1.5 spaces for each employee or faculty member plus 1 space for every 20 square feet of seating area in auditorium or assembly area.
High schools and colleges	2 spaces for every 3 employees or faculty members plus 1 space for every 4 students.
Hospitals	To be determined with master plan or per ITE.
Libraries, museums and art galleries	1 space for each 400 square feet of gross floor area.
C. Commercial Uses.	
Amusement parks	1 space for each 500 square feet of park area.
Art galleries	1 space for each 300 square feet of gross floor area.
Automobile, boat, recreational vehicle or small machinery rental or sales; service	1 space for each 500 square feet of gross floor area plus 1 space for each 2,000 square feet of outdoor display or service area.

garages, nurseries and garden supply, building material yards.	
Auto service stations	2 spaces per bay plus 1 space for each employee.
Banks, post offices	1 space for each 250 square feet of gross floor area. [Drive-up windows shall have at least 80 lineal feet of driveway per window.]
Barber and beauty shops or schools, manicure shop	1 space for each 100 square feet of gross floor area.
Business and professional offices	1 space for each 325 square feet of gross floor area. If the office space utilizes partitions rather than separate spaces or rooms, then 1 space for each 200 square feet of gross floor area.
Clinics, psychologist, medical offices, medical laboratories, medical uses.	1 space for each 200 square feet of gross floor area.
Commercial recreation, indoor, health club, roller or ice skating rink, bowling, racquetball or similar facilities (except as otherwise provided)	1 space for each 150 square feet of gross floor area.
Dance halls, assembly halls and sports arenas, bars with live entertainment, nightclubs	1 space for each 4 fixed seats. Where no fixed seats are provided, 1 space for each 150 square feet of floor used for assembly or dancing.
Flea markets	1 space for each 200 square feet of gross floor and display area.
Furniture and large appliance stores or repair shops, carpet shops and similar uses which handle only bulky merchandise	1 space for each 600 square feet of gross floor area.
Gaming	1 space for each 150 square feet of gross floor area.
Hotels, motels	1 space for each guest room; 1 guest space for every 10 rooms; 1 space for each employee of the largest shift.
Launderettes	1 space for each 5 washing machines.
Restaurants, bars, brew [pubs, tea houses] pubs	1 space for each 4 seats. Fast food restaurants shall provide 1 space for each 100 square feet of gross floor area and 1 space for every 2 [employees. Drive-thru restaurants shall provide at least 80 lineal feet of driveway per window.] employees of the largest shift.
Retail stores, secondhand shops, grocery stores, repair shops, etc., except as otherwise specified herein.	1 space for each 300 square feet of gross floor area.

Shopping center	1 space for each 250 square feet of gross floor area.
Theaters	1 space for each 4 seats.
Veterinarian, dog grooming	1 space per each 250 square feet of gross floor area.
D. Industrial Uses.	
Warehouse, storage building, wholesale operations	1 space for each 1,000 square feet of gross floor area plus 1 space for each [employee.] employee of the largest shift.
Manufacturing plant	1 space for each 500 square feet of gross floor area.
Laboratories and research facilities (non-medical)	1 space for each 400 square feet of gross floor area.
Large machinery and equipment rental or sales	1 space for each 600 square feet of gross floor area.
E. Other Uses.	Off-street parking requirements for uses not [herein specified shall] specified in this Division 2.2 must be determined by the [director.] Director.
[F. Determination by the Director.]	[Upon submittal of accredited documentation (e.g. latest version of ITE parking manual); the director may modify the parking requirements specified herein, or may request commission approval of such a modification.]
[G.] F. Handicapped Parking.	The number of handicapped parking spaces provided [shall] must be [as required by the [Building Code currently adopted by Carson City and ADA/ANSI standards.]] in accordance with the International Building Code, as adopted by the City.
[H. Joint Uses and Ancillary Uses.]	
[1. Where adjoining parcel owners wish to cooperate in the establishment and operation of joint parking facilities in situations where the maximum parking demands are generated at different times by the established uses, application may be made to the director to combine facilities and to thereby reduce the total number of off-street parking spaces required.]	
[2. Where a motel or hotel use includes ancillary restaurant, bar, gaming and convention facility uses, application may be made to the director to reduce the off-street parking space requirement up to a maximum	

of 30% of the off-street parking required for ancillary uses only.]	
[I. Downtown Mixed-Use District.]	
[Parking requirements for projects within the downtown mixed-use zoning district shall be established by the requirements of Division 6 (downtown mixed-use district) of the development standards and shall supersede the parking requirements above.]	

SECTION XXXX:

That Title 18 Appendix (CARSON CITY DEVELOPMENT STANDARDS), Division 2 (PARKING AND LOADING is hereby amended by adding thereto a new Section 2.25 (Joint parking and ancillary uses) (**bold, underlined** text is added, [~~stricken~~] text is deleted) as follows:

2.25 Joint parking and ancillary uses.

- 1. Adjoining property owners whose properties with different uses generate maximum parking demands at different periods throughout the day may combine and jointly operate parking facilities. Such owners may request a reduction in the total number of off-street parking spaces that are required pursuant to this Title 18 Appendix by submitting an application to the Director in the manner prescribed by the Department.**
- 2. The owner of a development property may request a reduction in the total number of off-street parking spaces that are required if multiple uses exist on the property.**
- 3. The owner of a motel or hotel that includes as an ancillary use a bar, restaurant, gaming establishment or convention facility may request a reduction in off-street parking spaces that are required, up to not more than 30 percent of the off-street parking required for the ancillary use.**
- 4. A request for any reduction in parking spaces as described in this section may be made by submitting an application to the Director in the manner prescribed by the Department. In reviewing an application, the Director may require an analysis of parking demands to be completed. The Director shall issue a determination on an application as soon as reasonably practicable.**
- 5. If any provision of this section conflicts with Division 6 of this Title 18 Appendix governing parking requirements in the Downtown Mixed-Use 9 (DT-MU) district, the provision of Division 6 shall be deemed the controlling provision.**

SECTION XXXX:

That Title 18 Appendix (CARSON CITY DEVELOPMENT STANDARDS), Division 2 (PARKING AND LOADING), Section 2.3 (General parking requirements) is hereby amended (**bold, underlined** text is added, [~~stricken~~] text is deleted) as follows:

2.3 General parking requirements.

1. Any off-street parking area that abuts or faces a single-family, two-family, or multi-family residential district or residential use must, in a manner satisfactory to the Director, include the use of screening located along the side of the parking area abutting or fronting on the residential district or residential use.
2. A parking lot for a business must be paved using a hard surface material such as asphalt, concrete, turf stone paver or other similar surface material approved by the Director. Gravel and other similar surface materials may be used for storage and display areas only.
3. If a parking area is not available on a building site, off-street parking may be authorized for the parcel in a location not farther than three hundred (300) feet from the building site upon the issuance of a special use permit authorizing the off-site parking. An applicant for such a special use permit may also request a modification to the distance requirement set forth in this subsection by including with his or her application properly accredited documentation as supporting material, including, without limitation, the most current publication of the trip and parking generation report issued by the Institute for Transportation Engineers. Upon receipt of such accredited documentation, the Director may elect to administratively authorize the requested modification to the distance requirement or cause the request to be placed on an agenda for a public meeting of the Commission for consideration.
4. Except as otherwise provided by CCMC, a parking lot:
 - (a) May only be used for vehicle [~~parking; and~~] **and occasional special events as may be authorized by CCMC; and**
 - (b) May not be used for the storage of an inoperable or unlicensed vehicle or the repair, dismantling or servicing of a vehicle.
5. Except as otherwise provided in this subsection, a driveway or any other area used or intended to be used as a parking space, the use or intended use of which requires one (1) or more vehicles to be moved so as to allow the ingress or egress of another vehicle, shall not be deemed compliant with any off-street parking requirements. Such a parking space may be deemed compliant with off-street parking requirements if the parking area is authorized by the provisions of [~~Division 6.6.5~~] **section 6.6 of Division 6** of **this Title 18** Appendix or if the parking area is located within:
 - (a) A single-family residential development that:
 1. Is authorized for the parking pursuant to a special use permit;
 2. Has internal and abutting public streets which [~~provides~~] **provide** parking on both sides of **the** internal and abutting public streets within the boundaries of the

development or, in such circumstances where on-street parking is not provided, has guest parking spaces which are provided within the boundaries of the development at an increased ratio of one (1) space for each unit;

3. Provides a tandem parking space on each individual lot for the exclusive use of the lot;
 4. Uses a minimum dimension of ten (10) feet wide by twenty (20) feet in length for each tandem parking space which is used, excluding the width of any adjoining sidewalk.
 5. Provides an enclosed, covered structure for at least one (1) of the two (2) spaces of each tandem parking space; and
 6. Uses a minimum depth of twenty (20) feet for each driveway, excluding the width of any adjoining sidewalk;
- (b) A planned unit development that:
1. Provides a tandem parking space on each individual lot for the exclusive use of the lot;
 2. Uses a minimum dimension of ten (10) feet wide by twenty (20) feet in length for each tandem parking space which is used, excluding the width of any adjoining sidewalk;
 3. Provides an enclosed, covered structure for at least one (1) of the two (2) spaces of each tandem parking space; and
 4. Uses a minimum depth of twenty (20) feet for each driveway, excluding the width of any adjoining sidewalk;
- (c) A mobile home park for the use of an individual mobile home; or
- (d) A recreational vehicle park.
6. If the calculation of a required number of off-street parking spaces results in a fractional space, any fraction up to one half (1/2) of one (1) parking space must be disregarded, and any fraction of one-half (1/2) of one (1) parking space and above must be counted as an additional space that is required.
 7. A commercial truck or trailer, other than a commercial van or pickup truck that is used for personal transportation, or vehicular equipment of a commercial or industrial nature, is prohibited from parking in any district except:
 - (a) As specifically authorized as a use in that use district;
 - (b) On residential parcels that are one (1) acre or larger in size, if the truck [or] trailer **or equipment** does not exceed ten (10) feet in height and twenty-two (22) feet in length, is not parked within a setback and is screened from view from any sidewalk, roadway or adjacent parcel;
 - (c) Where the truck [or] trailer **or equipment** is deemed to be a vehicle of historic significance, it is parked temporarily for the purpose of restoration and it is not being used for a commercial purpose; or

- (d) Where the truck ~~[or]~~ , trailer **or equipment** is temporarily parked and actually and expeditiously being used in the loading or unloading of merchandise, or where the truck ~~[or]~~ , trailer **or equipment** is being used in conjunction with the performance or provision of a repair, construction or similar essential use or service where it is temporarily parked.
8. Except as otherwise provided in CCMC ~~[Sections]~~ 8.10.090 and 13.03.190, the owner of a public and private parking lot shall not allow any recreational vehicle to park and to be occupied for living or sleeping purposes.
9. A recreational vehicle may not be parked for living purposes except in an area approved as a recreational vehicle park or where authorized by CCMC ~~[Section]~~ 18.05.030.
10. Except as otherwise provided in subsection 11, if an existing building that is located within a residential office, general office or redevelopment district is converted to a use requiring more parking spaces than the existing use, on-street curb parking may be counted towards the total number of required parking spaces if:
- (a) Adequate off-street parking space is not available or the Commission determines that strict compliance with the new parking space requirements as a result of the conversion would adversely affect the character of the neighborhood;
 - (b) Not less than fifty (50) percent of the required number of parking spaces will be provided off-street;
 - (c) The number of curb parking ~~[space]~~ spaces adjacent to the exterior boundaries of the property is limited to not more than fifty (50) percent of the total number of authorized on-street parking;
 - (d) On-street parking is not deducted from the total number of required off-street parking spaces for car, truck or trailer rental agencies or property zoned for an air industrial park use district; and
 - (e) Allowable on-street parking is not located upon any street or roadway that is designated as an arterial ~~[street or roadway]~~ in the master plan.
11. Notwithstanding any other provision of this ~~[section,]~~ **Division 2.3**, all required parking for new construction must be located off-street.
12. Any maintenance that requires the restriping or altering of a parking lot is prohibited without the approval of the Director.
13. All applicable sight distance requirements must be met in each use district.

SECTION XXXX:

That Title 18 Appendix (CARSON CITY DEVELOPMENT STANDARDS), Division 2 (PARKING AND LOADING), Section 2.4 (Off-street loading and unloading) is hereby amended (**bold, underlined** text is added, ~~[stricken]~~ text is deleted) as follows:

2.4 Off-street loading and unloading.

In addition to the required off-street parking area for every building used for commercial or industrial purposes in any commercial or industrial area outside the downtown area, off-street loading and unloading space ~~[shall]~~ **must** be provided at the rear of the primary building or use, and screened with walls, landscaping or a ~~[combination.]~~ **of walls and landscaping.**

Off-street loading or unloading space may be provided at the side or the front of the building only if **the space is** landscaped and screened by walls ~~[which]~~ **that** are architecturally integrated with the main structure. Loading, ~~[unloading,]~~ **unloading** or maneuvering **of a vehicle** may not take place within the aisleway, traffic lane or parking area on parcels exceeding a three thousand (3,000) square feet area except in the downtown area.

Any individual loading space ~~[shall]~~ **must** be at least fifteen (15) feet wide by sixty (60) feet long and have a minimum height clearance of fourteen (14) feet when full size tractor rigs are used for shipping and receiving. When a building requires less area for loading and unloading space, a reduction of the size and number of spaces may be approved by the ~~[director]~~ **Director** based upon the applicant's presentation of information and justification of the request and further upon determining compliance with the other provisions of this ~~[division.]~~ **Division.**

The number of such spaces provided ~~[shall]~~ **must** be based on the operating characteristics of the use. ~~[Restaurants and food sales businesses shall provide two (2) spaces.]~~



Typical loading/unloading area screened and oriented away from the street.

SECTION XXXX:

That Title 18 Appendix (CARSON CITY DEVELOPMENT STANDARDS), Division 3 (LANDSCAPING), Section 3.1 (Purpose) is hereby amended (**bold,** **underlined** text is added, ~~[stricken]~~ text is deleted) as follows:

3.1 Purpose.

The purpose of this ~~[section]~~ **Division** is to ~~[set forth]~~ **establish landscaping** standards for new and expanded development within the ~~[city,]~~ **City,** enhance the aesthetic appearance of the community, including the visual appearance of streets, complement the visual effect of buildings,

aid in the enhancement of property values, provide buffers between various land uses, provide protection from intense land use activities, insulate from the effects of weather conditions, including the provision **of** shading for parking lots, and aid in conserving water by encouraging the use of varieties of plants indigenous to arid regions. These standards shall be **deemed** the minimum requirements necessary for the promotion of the ~~[foregoing purposes. Text and diagrams describing landscaping and irrigation requirements, planting details, approved tree and shrub lists and other examples for the requirements of this division are in the appendix to this section, and available on the Carson City website and on CD at the planning division office.]~~ **purpose as described in this section.**

SECTION XXXX:

That Title 18 Appendix (CARSON CITY DEVELOPMENT STANDARDS), Division 3 (LANDSCAPING), Section 3.2 (Applicability) is hereby amended (**bold, underlined** text is added, ~~[stricken]~~ text is deleted) as follows:

3.2 Applicability.

~~[These landscape standards shall]~~ **The landscaping standards set forth in this Division** apply to new construction ~~[of the following projects:~~

~~Multi-family Residential with 3 or more units;~~

~~Institutional Uses;~~

~~Office Uses;~~

~~Commercial Uses;~~

~~Industrial Uses;~~

~~Public Uses.~~

~~The director]~~ **and the expansion of existing buildings and uses located in all zoning districts except single-residential uses.**

The Director may approve variations to the standards set ~~[out in this division if they respond more appropriately to]~~ **forth in this Division if the Director determines that a variation is more suitable for** a particular site ~~[and]~~ **, the variation will provide an equivalent means of achieving the [intent of the landscape standards.] purpose of this Division as described in section 3.1 and the variation will not be a detriment to the health, safety or general welfare of the community.**

Any expansion of ~~[a]~~ **an existing** building **that is not already** in compliance with the ~~[landscape requirements in this division and Title 18 of the Carson City Municipal Code]~~ **standards set forth in this Division** must comply with ~~[landscape standards by twice the proportion to the expansion pursuant to Table 3.1 (Expansion Compliance).]~~ **the standards in the following table:**

**Table 3.1
Expansion Compliance**

< 5% Building Expansion	No Requirements
≤ 10% Building Expansion	20% of Landscape Requirements for entire site
≤ 20% Building Expansion	40% of Landscape Requirements for entire site
≤ 30% Building Expansion	60% of Landscape Requirements for entire site
≤ 40% Building Expansion	80% of Landscape Requirements for entire site
≥ 40% Building Expansion	100% of Landscape Requirements for entire site

SECTION XXXX:

That Title 18 Appendix (CARSON CITY DEVELOPMENT STANDARDS), Division 3 (LANDSCAPING), Section 3.3 (Landscape and irrigation plans) is hereby amended (**bold, underlined** text is added, ~~[stricken]~~ text is deleted) as follows:

3.3 Landscape and irrigation plans.

A landscape and irrigation plan ~~[shall]~~ **must** be filed with the ~~[city]~~ **City** and approved by the ~~[director prior to]~~ **Director before** the approval of a site plan or issuance of a building permit. The plan ~~[shall]~~ **must** be prepared by a landscape architect registered in ~~[the state of Nevada, or other]~~ **this State or by a** person ~~[permitted]~~ **who is authorized** to prepare landscape plans pursuant to Chapter 623A of ~~[the Nevada Revised Statutes (NRS). Landscaping on all commercial/industrial projects must be installed or supervised by an individual at the job location with at least one of the following credentials: Certified Landscape Technician, Licensed Landscape Contractor, Certified Landscape Professional, ISA Certified Arborist, Registered Landscape Architect, a C10 Qualified Employee as recognized by the State Contractor's Board, or an equivalent certification, approved by the parks and recreation department.]~~ **NRS.**

3.3.1 The landscape and irrigation plan ~~[shall]~~ **must** be clearly and neatly drawn in a commonly used scale such as engineer or architect ~~[(i.e.,)]~~ **, including measurements where** 1 inch equals 20 feet or ¼ inch equals 1 ~~[foot]~~ **foot** and ~~[shall]~~ **must** include a north arrow, ~~[owner/developer]~~ **the owner or developer** name, project location, location of adjacent streets, property lines, easements, sidewalks, drives, paved areas, sign and light standard locations, building outlines, eaves, topography and grading, existing trees or other natural features influencing the use of the site, utilities either overhead or underground and ground-mounted equipment such as vaults, transformers and air conditioning units.

3.3.2 The ~~[plans shall]~~ **landscape and irrigation plan must** include landscape calculations relevant to the application of the standards of this section and ~~[shall include]~~ **must further contain** a plant list in a legend format giving the common and botanical names of each plant with a key number or identifying symbol assigned to each plant, the size of the plant, its spacing **, an indicator of pollinator species** and the quantity to be used.

- 3.3.3 The landscape ~~[plans shall]~~ **portion of the plan must** include construction details for planting, staking, soil amendments and any special requirements for the project and may be **provided as** an attachment to the ~~[plans-]~~ **plan.**
- 3.3.4 ~~[Irrigation plans shall]~~ **The irrigation portion of the plan must** be drawn at the same scale as the landscape ~~[plans]~~ **portion of the plan** and include specifications which comply with the most current Uniform Plumbing Code as adopted by the ~~[city-]~~ **City. Detailed information** showing **the** number of ~~[emitters/bubblers]~~ **emitters or bubblers** and **the** rate or gallons per hour (gph) or gallons per minute (gpm) for all plants and ~~[trees. See emitter detail in appendix for example-]~~ **must be included on all submitted plans.**
- 3.3.5 ~~[Identification and description of automatic]~~ **Automatic** irrigation components ~~[to insure]~~ **must be identified and described in the landscape and irrigation plan to ensure** that vegetation is adequately serviced through water conserving features. Overhead sprinkler irrigation is only allowed on turf areas or other areas requiring overhead sprinkler irrigation.
- 3.3.6 All drip and bubbler irrigation systems for trees and shrubs must be on ~~[a separate]~~ **an** irrigation zone **that is separate** from turf irrigation zones. The ~~[utilization]~~ **use** of water savings irrigation design is ~~[encouraged-]~~ **encouraged** and **the** incorporation of separation of irrigation zones **must be** based on water needs.
- 3.3.7 ~~[Indication]~~ **An indication** of the irrigation system point of connection to the water supply and size, **available** water pressure ~~[available-]~~ and maximum demand of the system in gallons per ~~[hour/minute shall be provided-]~~ **hour (gph) or gallons per minute (gpm) must be provided with the landscape and irrigation plan.**
- 3.3.8 ~~[Irrigation]~~ **All irrigation** equipment specified **in the landscape and irrigation plan** must be identified by ~~[manufacturer's]~~ **manufacturer** name and equipment identification number.
- 3.3.9 All equipment locations ~~[shall]~~ **must** be indicated **in the landscape and irrigation plan** for irrigation valves, controllers, hydrants, quick coupler valves, sprinkler heads, backflow preventors and pipe sizing.
- 3.3.10 Additional irrigation details **for the landscape and irrigation plan in addition to the requirements established by this section** may be ~~[needed to clarify particular situations as shown in typical irrigation legend in the Appendix-]~~ **required by the Director.**
- 3.3.11 Typical details ~~[shall]~~ **that may be required for irrigation** include **, without limitation,** backflow prevention devices, backflow enclosure valves, irrigation heads and irrigation controllers. ~~[Note that pressure]~~ **Pressure** vacuum breakers are allowed for residential applications, and reduced pressure principle backflow prevention devices are required in all other applications.
- 3.3.12 All ~~[below ground]~~ equipment **below ground** must be located within boxes of adequate size to protect the components.
- 3.3.13 Schedule 40 PVC pipe **or its equivalent or greater** is required for all pressure **main** lines and under all paved areas.

- 3.3.14 Piping must be installed a minimum of 18 inches underground for non-pressure irrigation lines and 24 inches underground for constant pressure irrigation lines.
- 3.3.15 Freeze protection [~~and/or~~] **or** winterization for the irrigation system [~~shall~~] **must** be provided.
- 3.3.16 Schedule 40 PVC pipe or **its** equivalent **or greater** sleeving under sidewalks or driveways is required.
- 3.3.17 Landscape irrigation water use [~~shall~~] **must** be separately metered or sewer charges [~~shall~~] apply for other than residential uses.
- 3.3.18 For any project located in the Wildland Urban Interface area, the landscape and irrigation plan must comply with the International Urban Interface Code and the Northern Nevada Urban Interface Code amendments, as adopted by the City.**
- 3.3.19 Except as otherwise approved by the Director, not less than 50 percent of plants to be used must be pollinator-friendly and indicated as such in the landscape and irrigation plan.**

SECTION XXXX:

That Title 18 Appendix (CARSON CITY DEVELOPMENT STANDARDS), Division 3 (LANDSCAPING), Section 3.4 (Preservation and protection of existing trees and shrubs) is hereby amended (**bold, underlined** text is added, [~~stricken~~] text is deleted) as follows:

3.4 Preservation and protection of existing trees and shrubs.

[Trees] **Existing trees** and significant shrubs [~~shall~~] **must** be preserved whenever possible and shall be [~~considered part~~] **deemed a component** of the required landscape area. Preservation of existing 4-inch caliper [~~(6-8 foot for evergreens)~~] healthy trees [~~will be~~] **, commonly 6 to 8 feet in height for evergreen trees, are** eligible for a 2:1 credit toward the total tree requirement if approved by the [~~director,~~] **Director**, up to a maximum of 25 percent of the requirement for trees on the site. [~~Provide an overlay on all submitted~~] **Submitted** plans **must include an overlay** of all existing trees with caliper [~~(deciduous)~~] **for deciduous trees** or height [~~(evergreen)~~] **for evergreen trees** and significant shrubs on the site and clearly mark which will be retained on the site and which are proposed to be removed.

- 3.4.1 Deciduous trees with a trunk diameter of 4 inch or greater at a point four and ½ foot above ground level or evergreen trees 6 foot or greater in height or significant [~~shrubs, shall~~] **shrubs may** not be removed unless authorized by prior written approval from the [~~director. The~~] **Director. An** applicant is encouraged to submit a report to the [~~director~~] **Director** prepared by a certified arborist, or licensed design professional detailing a reason for a request to authorize removal of trees and significant shrubs. After consultation with **any** other applicable [~~city divisions, the director~~] **City**

department as may be appropriate or required, the Director may authorize the removal of existing trees and shrubs if ~~[any of the following criteria exist:]~~ :

1. The health or condition of the tree presents a clear danger to people or property or it constitutes a nuisance.
2. ~~[When the]~~ **The** tree or shrub is located within the footprint of the building, or ~~[when a]~~ **the** tree trunk or shrub is so close to the building area that construction would result in irreparable damage or death to the plant.
3. Access is so restricted to the site that removal is necessary and unavoidable.
4. The elevation will be severely changed by ~~[grading/building/development.]~~ **grading, building or development.** The tree or shrub cannot remain on the site as a result of the change in elevation.
5. ~~[Any other instances]~~ **Removal is** deemed appropriate **under circumstances as determined** by the ~~[director shall be considered.]~~ **Director.**

3.4.1.1 All trees removed from a site, which were not previously approved under the criteria outlined in subsection 3.4.1 ~~[above,]~~ **require** replacement by ~~[+]~~ **one** of the methods listed below. As an example, removal of a 6-inch diameter tree would require replacement of the tree with 4, 3-inch caliper trees or the equivalent.

- a. Deciduous trees require replacement with a 2:1 caliper ratio tree, with a minimum caliper of 2 inch and a maximum of 3 inch per tree.
- b. Evergreen trees require replacement with a 2:1 height ratio, with a height minimum of 6 foot and maximum of 8 foot per replacement tree.
- c. Tree replacement may require off-site mitigation, including planting of trees on public property. Off-site mitigation ~~[shall require approval by the parks and recreation director.]~~ **must be approved by the Director of the Department of Parks, Recreation and Open Space.** Payment of fees **and associated costs** to purchase and plant ~~[trees, as well as associated costs are required, rather than]~~ **are required in lieu of** actual planting of trees on public property. Appropriate fees which are based on the placement of trees in the right-of-way program as periodically updated ~~[shall]~~ **must** be paid to the ~~[parks and recreation department. Provide the planning department]~~ **Department of Parks, Recreation and Open Space. The Department must be provided** with a copy of receipt for payment of required tree ~~[replacement/mitigation]~~ **replacement or mitigation** fees. Payment is required ~~[prior to the]~~ **before a** building permit ~~[being]~~ **may be** issued.

3.4.2 Tree Protection. All deviations from ~~[the tree protection code]~~ **this Division** must be approved by the ~~[planning division.]~~ **Planning Division of the Department.** ~~[Construction]~~ **It is hereby recognized that construction** activities ~~[can]~~ **may** severely damage or kill trees. ~~[See tree retention/protection, root pruning detail, and excavation adjacent to retained trees in appendix for additional requirements and information.]~~ The following practices must be followed during all construction activities:

1. Pruning of live branches from trees identified for preservation is prohibited except in conjunction with subsection 3.4.3. ~~[Pruning Standards. See pruning details in appendix for more requirements and details.]~~
2. Tree protection fencing and protection ~~[is]~~ **are** required around all trees identified for preservation. ~~[See detail in appendix. Construct protection fencing which]~~ **Protection fencing that** complies with the [following:] **following must be constructed:**
 - a. Protective fencing must be constructed of 4 foot wide minimum orange netting or chain link. Fencing must be a minimum of 5 feet outside the tree drip line. Fences must be mounted on above ground concrete footings, which ~~[shall]~~ **may** not be driven into the ground. Spacing ~~[shall be no]~~ **must be not** more than 10 ~~[foot.]~~ **feet.** This detail ~~[shall]~~ **must** be placed on all grading, demolition and improvement plans.
 - b. Protective fencing ~~[shall]~~ **must** enclose the entire area under the canopy drip line of the tree protection zone throughout the life of the project, or until work within the tree protection zone is completed. The fence ~~[shall]~~ **must** not be moved during construction phase without prior approval of the qualified site professional utilizing ~~[the]~~ best management practices. The protective fence may be removed at final grading inspection or at the time final landscaping is installed. ~~[Refer to detail in appendix for sample drawing.]~~
 - c. A sign describing the fence as protective tree fencing ~~[shall]~~ **must** be prominently displayed on each fence. The sign must be a minimum of 8.5 by 11 inches and clearly state: "Tree Protection Zone. This fence shall not be removed and is subject to penalty per Carson City Municipal Code." ~~[Refer to detail in appendix for sample drawing.]~~
3. If protective fencing cannot be placed around the entire tree protection zone, ~~[then]~~ protective fencing ~~[shall]~~ **must** be placed around the trunk of the ~~[tree(s)]~~ **tree** but only after prior approval of the proposal by the ~~[planning division.]~~ **Planning Division of the Department.** 2 foot by 4 foot lumber ~~[shall]~~ **must** be secured with banding around the trunk of ~~[tree(s)]~~ **any tree** to be preserved. ~~[Do not attach boards]~~ **Boards** or banding **may not be attached** directly into the bark or trunk of the tree.
4. There should be no activity in the tree protection zone without prior approval by the ~~[planning division.]~~ **Planning Division of the Department.** The following are prohibited activities within the tree protection zone:
 - a. Soil disturbance, including excavation, trenching or grade change without prior approval of the ~~[planning division.]~~ **Planning Division of the Department.**
 - b. Spoils, non-spoils, storage of any equipment, materials or parking.
 - c. Placement of non-spoil material or equipment.

5. ~~[Apply 6]~~ **Six** inches of wood chips or bark **must be applied** over the root zone of trees within the protective ~~[barriers. Mulching]~~ **barriers and mulching** areas outside of protective barriers ~~[will help]~~ **is encouraged** to **help** minimize compaction from construction traffic adjacent to sensitive root zones.
 6. Hand digging ~~[shall be]~~ **is** required to determine if lateral roots are present on trees in the direction of proposed foundation location. If support roots are found, it is recommended that correct root pruning is ~~[performed, so as to not compromise]~~ **performed to avoid compromising** the stability of the ~~[tree(s).]~~ **tree.**
 7. ~~[Correctly and cleanly prune exposed]~~ **Exposed** roots that are not to be saved back to the soil horizon **must be correctly and cleanly pruned** in compliance with ~~[detail in]~~ subsection 3.4.3. Pruning should be supervised by a qualified licensed professional and should be performed to ~~[ISA standards (see details in appendix).]~~ **International Society of Arboriculture, Western Chapter standards.**
 8. ~~[Promptly cover exposed]~~ **Exposed** roots **must be promptly covered** with a damp ~~[tarp(s) which are kept moist, or]~~ **tarp that is kept moist or other** material that will ~~[keep]~~ **prevent the** roots from drying.
 9. ~~[Irrigate]~~ **Irrigation** within the dripline of trees once a week **is required** if natural precipitation does not occur during spring, summer and fall.
 - ~~[10. See detail for tree retention, root pruning and excavation adjacent to retained trees in appendix.]~~
- 3.4.3 Pruning Standards. ~~[No trees]~~ **Any tree located** on commercial or industrial land ~~[which]~~ **that** is part of required landscaping ~~[shall]~~ **may not** be pruned in a manner that impairs the health of the tree. All pruning performed on required trees ~~[shall]~~ **must** be in accordance with pruning standards published by the American National Standards Institute (ANSI), per ANSI A300 Part 1 Pruning, and International Society of Arboriculture, Western Chapter. ~~[See appendix regarding pruning detail.]~~
1. ~~[ANSI]~~ **In accordance with American National Standards Institute (ANSI) provisions,** pruning standards require in part, the use of certain tools, cutting ~~[techniques,]~~ **techniques** and pruning methods to be followed, including not leaving branch stubs, few or no heading cuts, not cutting off the branch collar ~~[not]~~ **, not** making a cut flush with the ~~[trunk,]~~ **trunk,** not topping or lion's tailing ~~[("gutting-out")]~~ **, commonly known as gutting-out** a tree by removing a large number of the inner ~~[branches,]~~ **branches,** not removing more than 25 percent of the foliage of a single branch, not removing more than 25 percent of the total tree foliage in a single year, not damaging other parts of the tree during pruning and not using wound paint. 50 percent of the foliage should remain evenly distributed in the lower 66 percent of the tree canopy after pruning.
 2. All pruned material ~~[shall]~~ **must** be controlled and removed in a manner to prevent damage to the surrounding plant material and property. Tree topping, tipping and heading back are all terms used to describe severe cutting back of a tree's crown and is prohibited on any tree which is part of required landscaping and strenuously discouraged on any other trees on the site.

3. Trees severely damaged by storms or other causes, or trees under utility wire or other obstructions, where other pruning practices are impractical, may be exempted from the prohibition of topping, tipping and heading back, at the discretion of the ~~[director.]~~ **Director**. A letter of request must be submitted to the director and approved ~~[prior to]~~ **any** such severe pruning.

SECTION XXXX:

That Title 18 Appendix (CARSON CITY DEVELOPMENT STANDARDS), Division 3 (LANDSCAPING), Section 3.5 (Landscape design standards) is hereby amended (**bold, underlined** text is added, ~~[stricken]~~ text is deleted) as follows:

3.5 Landscape design standards.

- 3.5.1 All landscaping ~~[shall]~~ **must** aesthetically enhance and be compatible with the site area. Landscaping ~~[shall]~~ **must** be installed to enhance the view of the site from **any** public ~~[street(s)]~~ **street** and adjacent properties.
- 3.5.2 A minimum of 20 percent of the ~~[site's]~~ impervious surfaces **of a site**, excluding the building coverage, ~~must~~ be pervious areas of landscape material. The area within the public right-of-way adjacent to a site must be landscaped and may be counted for 25 percent of the total required landscaped area. In areas with right-of-ways over 20 feet in depth, the ~~[director.]~~ **Director** may modify or waive the requirement for landscaping of the right-of-way. The requirement may also be waived by the ~~[director if the public agency denies]~~ **Director if** permission for an encroachment permit or lease of the area to be ~~[landscaped.]~~ **landscaped would otherwise be denied.**

SECTION XXXX:

That Title 18 Appendix (CARSON CITY DEVELOPMENT STANDARDS), Division 3 (LANDSCAPING), Section 3.6 (Turf) is hereby amended (**bold, underlined** text is added, ~~[stricken]~~ text is deleted) as follows:

3.6 Turf.

The following standards for the use of turf in landscaping are intended to conserve water by minimizing the need for water for irrigation and minimizing irrigation water wasting.

- 3.6.1 Turf areas ~~[shall]~~ **may** not constitute more than the percentage of the total landscape area as established by the table ~~[below]~~ **set forth in this section** below unless approved by special use permit.

Table - Permitted percentage of turf area. Turf area is shown as a percentage of the total landscaped area:

Development Area	Permitted Turf Area
Less than 5 acres (ac.)	[50%] 40%
5 ac. to less than 10 ac.	[40%] 30%
10 ac. to less than 15 ac.	[30%] 20%
15 ac. or larger	[25%] 15%

3.6.2 Turf [~~shall~~] **may** not be used on slopes greater than 4:1 or in areas less than 8 feet in width or length.

3.6.3 Where landscape areas abut sidewalks, drive-aisles, parking areas or other hardscape surfaces, a minimum 3-foot wide landscape buffer area must be provided between any turf areas and the hardscape to capture irrigation overspray and runoff. The buffer area may be **composed of** drip-irrigated plant materials or non-living landscape materials.

3.6.4 Artificial turf may be used if it is made of a quality that closely resembles natural turf. If artificial turf is used, it must be perpetually maintained in accordance with the applicable maintenance schedule or care guidelines for the product as recommended by the manufacturer. The use of artificial turf is subject to the turf area limitations set forth in subsection 3.6.1.

SECTION XXXX:

That Title 18 Appendix (CARSON CITY DEVELOPMENT STANDARDS), Division 3 (LANDSCAPING), Section 3.7 (Trees) is hereby amended (**bold, underlined** text is added, [~~stricken~~] text is deleted) as follows:

3.7 Trees.

3.7.1 The minimum number of trees [~~shall be~~] **required is** one (1) tree per four hundred (400) square feet of landscape area. Additional trees are required if the number of trees for parking areas and along right-of-way areas as described in subsections 3.7.1.1 and 3.7.1.2 exceed this minimum. The Director may modify this standard for public uses such as parks.

1. Included in the minimum required number of trees, a minimum of one (1) shade tree must be planted for every ten (10) parking spaces or fraction thereof, and distributed throughout the parking area surface to provide even shading within the parking lot. For example, eighteen (18) parking spaces [~~shall~~] require two (2) trees. A minimum of one (1) deciduous tree [~~shall~~] **must** be placed in each standard sized parking island.
2. Included in the minimum required number of trees, at least one (1) tree [~~shall~~] **must** be placed along the right-of-way frontage for every thirty (30) lineal feet of right-of-way

at a point not more than twenty (20) feet from the right-of-way. The Director may allow for different spacing or locations of trees for projects with outdoor display such as automobile sales lots.

3.7.2 Where more than ten (10) deciduous trees are provided as a part of the landscape plan, a ~~[minimum of fifty percent (50%)]~~ **maximum of 60 percent (60%)** of the trees ~~[shall]~~ **may** be of ~~[a different]~~ **the same** species to ensure diversity. Additional species may be required on larger ~~[projects.]~~ **project as determined by the Director.**

3.7.3 Deciduous trees must be planted not less than 5 feet from any public right-of-way, curb, gutter, sidewalk or pathway. Evergreen trees are prohibited in any standard size parking island and must be planted not less than 10 feet from any public right-of-way, curb, gutter, sidewalk or pathway. Fruit bearing trees and other trees that flower or otherwise drop debris, including seed pods, may not be planted in any area where, at the time of planting or as they mature, the limbs or foliage of the trees will hang over a public right-of-way or sidewalk.

SECTION XXXX:

That Title 18 Appendix (CARSON CITY DEVELOPMENT STANDARDS), Division 3 (LANDSCAPING), Section 3.8 (Groundcover and shrubs) is hereby amended (**bold, underlined** text is added, ~~[stricken]~~ text is deleted) as follows:

3.8 Groundcover ~~(including shrubs.)~~ and shrubs.

3.8.1 Groundcover ~~[shall]~~ **must** be used to prevent erosion, inhibit weed ~~[growth,]~~ **growth** and present an aesthetically pleasing appearance when mature. Groundcover may include living plants such as turf, shrubs, vines, meadow grasses, flowers or other living covers. Ground cover and shrubs ~~[shall]~~ **must** be incorporated into all landscape plans in a balanced manner.

3.8.2 Non-planted, non-living materials such as wood chips, bark, decorative rock, mulch, stone or other non-living materials may be used as groundcover, and ~~[shall]~~ **must** be distributed throughout the site. All landscape areas ~~[shall]~~ **must** be covered with materials suitable for reducing dust and evaporation and ~~[shall]~~ **must** be designed to improve the aesthetic appearance of the area. An attractive mix of organic and non-organic materials is encouraged. ~~[Products which appear to be dirt shall not be used.]~~ **The use of any non-organic material that has the appearance of dirt is prohibited.**

3.8.3 A ratio of ~~[at least]~~ **not less than** 6 shrubs is required for each ~~[tree placed or retained on the site. If a large quantity of turf is proposed for the site, the required shrub count may be reduced after review and approval of the submitted landscaping plans by the planning division.]~~ **400 square feet of required landscape, excluding turfed areas.**

SECTION XXXX:

That Title 18 Appendix (CARSON CITY DEVELOPMENT STANDARDS), Division 3 (LANDSCAPING), Section 3.9 (Streetscape) is hereby amended (**bold, underlined** text is added, [~~stricken~~] text is deleted) as follows:

3.9 Streetscape.

On arterial streets, minimum 10 foot wide landscape areas [~~shall~~] **must** be provided along the frontage of the site adjacent to the street. On all other streets, a minimum of 6 foot wide landscape area [~~shall~~] **must** be provided along the frontage of the site adjacent to the street. [~~On~~] **For** sites with unique constraints, the [~~director~~] **Director** may approve an alternative dimension if the alternative does not compromise the integrity of the landscape plan.

SECTION XXXX:

That Title 18 Appendix (CARSON CITY DEVELOPMENT STANDARDS), Division 3 (LANDSCAPING), Section 3.10 (Plant materials) is hereby amended (**bold, underlined** text is added, [~~stricken~~] text is deleted) as follows:

3.10 Plant materials.

3.10.1 The latest edition of the American Standard for Nursery Stock by the American Association of Nurserymen [~~shall be~~] **must be used as** the criteria for sizes and grades of plant materials. [~~No artificial~~] **Artificial** plants [~~are allowed~~] **, other than artificial turf where authorized, is prohibited** unless approved by the [~~director~~] **Director**. **Notwithstanding any other provision set forth in this Division, the Director may authorize three-dimensional objects, including, without limitation, boulders and sculptures, in lieu of trees and shrubs.**

All trees [~~to~~] **must** be number 1 grade nursery stock and meet current industry quality standards adopted by the American Association of Nurserymen, American National Standards Institute (ANSI) Z60 and NRS 555 (Regulations of Nursery and Nursery Stock). [~~All trees must comply with the following:~~] **The following restrictions apply to all trees:**

No girdling, kinked, circling or "J" roots;

No trees that have been topped;

No wounds in the trunk, bark or on limbs;

Insect and disease free, rodent and mechanical damage free;

No trees that have large nursery stakes through rootball or have been grown on a nursery stake;

Rootball to be appropriate to caliper and crown size;

[~~Trunk/crown~~] **Trunk or crown** structure and trunk taper to be appropriate for the species;

All graft unions to be healthy with trunk diameter below union larger than above union;

All trees to stand upright without stakes;

Roots, bark and shoot growth to give evidence of good tree vigor;

Any replacement of plant stock to be equal to original specification and approved by the ~~[owner's representative;]~~ **owner; and**

Any substitution of plant material must be submitted in writing for approval by the landscape architect or design professional and the ~~[planning division;]~~ **Planning Division of the Department.**

- 3.10.2 ~~[Container-grown shrubs shall]~~ **Container-grown, non-native shrubs should** be a minimum ~~[5-gallon]~~ **5-gallon** size at the time of planting, excluding trees and those plants grown in flats. **Container-grown, native shrubs may be a minimum 1-gallon size at the time of planting.** Perennials ~~[shall]~~ **must** be a minimum ~~[1-gallon]~~ **1-gallon** size at the time of planting.
- 3.10.3 Required evergreen trees ~~[shall]~~ **must** be a minimum of 6 feet in height at the time of planting and ~~[shall]~~ **must** not comprise more than 40 percent of the total number of trees or as dictated by the site and approved by the ~~[director.]~~ **Director.**
- 3.10.4 Required deciduous trees ~~[shall]~~ **must** be a minimum caliper of 2 inches at the time of planting. Using 3 inch maximum caliper new trees ~~[shall]~~ **may** reduce the number of required trees by 10 percent or **by a different percentage** as approved by the ~~[director.]~~ **Director.** This **provision** does not ~~[refer]~~ **apply** to required replacement trees as ~~[shown]~~ **described** in subsection ~~[3.4.1.1,]~~ **3.4.1.1** for trees removed without permission.
- 3.10.5 If additional trees beyond the minimum requirement are proposed, they may be smaller in size. The required number of trees in each category and total for the project must be clearly marked on the plan, with additional trees noted as supplemental.
- 3.10.6 Trees which overhang sidewalks, parking lots or streets ~~[shall]~~ **must** be free of thorns or fruit types that litter the ground. Evergreen trees are not permitted in standard sized parking islands.
- 3.10.7 Within an urban setting, the following types of trees ~~[shall]~~ **may** not be installed because of undesirable characteristics: 'Populus genus' ~~[(aspens,)]~~ **, commonly known as aspens,** poplars and ~~[(cottonwoods,)]~~ **cottonwoods,** 'Salix genus' ~~[(willows,)]~~ **, commonly known as willows** and 'Ulmus genus' ~~[(elms,)]~~ **, commonly known as elms.** New species ~~[which]~~ **that** do not exhibit undesirable characteristics are acceptable. Requests for waiver of this requirement may be considered by the ~~[director in appropriate instances.]~~ **Director at his or her sole discretion.** Developers are encouraged to protect and preserve existing healthy trees on site.
- 3.10.8 Tree selection for projects ~~[will]~~ **must** be guided by the approved Carson City tree list for commercial projects. Trees planted in the ~~[city will]~~ **City must** be installed ~~[according to the city's]~~ **in accordance with the** tree planting ~~[standards. The approved tree list and standard planting details are located in the appendix.]~~ **standards adopted by the City.**
- 3.10.9 Riparian Areas. Areas along established riparian corridors may ~~[utilize]~~ **use** native riparian trees and shrubs ~~[which]~~ **that** are identified ~~[on]~~ **in** the Carson City riparian area list. These materials may be planted along ~~[river/stream]~~ **river or stream** corridors within Carson City after approval of the intended choices and locations by the ~~[director. Request]~~

Director. A request for the use of riparian trees and shrubs outside of a riparian or wetland zone within the urban setting may be considered by the ~~[director in appropriate instances.~~ The approved riparian area tree and shrub lists are located in the appendix.] **Director at his or her sole discretion.**

3.10.10 Historic District Properties. Areas within the historic district are encouraged to ~~[utilize]~~ **use** trees and shrubs shown as noted ~~[on]~~ **in** the Carson City tree list for commercial projects, further noted as Carson City historic district preferred trees. ~~[The approved tree list with historic district preferred trees noted is located in the appendix.]~~

SECTION XXXX:

That Title 18 Appendix (CARSON CITY DEVELOPMENT STANDARDS), Division 3 (LANDSCAPING), Section 3.11 (Details) is hereby amended (**bold, underlined** text is added, ~~[stricken]~~ text is deleted) as follows:

3.11 Details.

- 3.11.1 Parking and driveway areas ~~[shall]~~ **must** include concrete curbs or similar improvements, as approved by the ~~[director]~~ **Director**, for protection of landscaping. Vehicle overhangs into landscaped areas ~~[shall]~~ **may** not exceed 2 feet. Planter areas ~~[shall]~~ **may** not be less than 72 square feet in size and ~~[shall]~~ **must** have a minimum width of 6 feet.
- 3.11.2 Drainage basins, when required, ~~[shall]~~ **must** be incorporated into the landscape design, ~~[utilize]~~ **use** non-buoyant landscape ~~[materials, and shall]~~ **and** be irrigated if landscaped. Access ~~[shall]~~ **must** be provided for maintenance. The landscaped basin area may ~~[count]~~ **be counted** as 10 percent of the total landscape requirement if the basin is not fenced with sight-obscuring materials and is landscaped along the perimeter to enhance the appearance.
- 3.11.3 Snow storage should be incorporated within the design of projects and should be oriented for maximum sun exposure for acceleration of melting. Driveways, drive aisles, sidewalks and landscape ~~[areas, cannot]~~ **may not** be used for snow storage. Drainage and run-off from snow storage areas ~~[shall]~~ **must** be considered in the design.
- 3.11.4 Soil in planted areas should be mechanically loosened to a minimum depth of 12 inches ~~[and/or]~~ **or** to the depth of the root ball and 3 times the diameter for trees and shrubs. Tests of soils, based upon one test per site ~~[(sites over 25,000 square feet in landscape area may require additional tests as required by the director), shall]~~ **, must** be conducted and appropriate soil amendments recommended. **Sites that are greater than 25,000 square feet in landscape area may be required to undergo additional testing at the discretion of the Director.** Soils should be improved by incorporating the recommended soil amendments into the loosened soil prior to planting.
- 3.11.5 All non-planted landscape areas ~~[shall]~~ **must** be covered with materials such as mulch. Products ~~[which appear to be]~~ **that have the appearance of** dirt ~~[shall]~~ **may** not be used. A

weed barrier fabric ~~[is required]~~ **must be used** under all rock and cobble mulches and **the use of** pre-emergent herbicide is recommended.

- a. Planted areas should be mulched to a minimum depth of 3 inches for organic mulches. ~~[No]~~ **The use of** fabric ~~[shall be used]~~ under wood ~~[mulch.]~~ **mulch is prohibited.**
 - b. ~~[Sufficient]~~ **A sufficient** quantity of rock mulch ~~[shall]~~ **must** be installed to completely cover all weed control fabric. Fabric ~~[shall]~~ **must** be trimmed back in compliance with landscaping details to allow for **the** future growth of plants. All rock mulch must be washed and cleaned ~~[prior to]~~ **before** installation. Large cobble mulch should include top dressing of smaller matching cobble or similar material. Nonporous material such as plastic sheeting ~~[shall]~~ **may** not be placed under the mulch.
- 3.11.6 All debris, including **, without limitation,** concrete, asphalt, wire, wood, steel and other foreign matter, must be removed from ~~[a planting area prior to]~~ **planting areas before** soil preparation or planting, and ~~[prior to]~~ **before a** request for a final inspection of the ~~[site.]~~ **is made.**
- 3.11.7 Conflicts ~~[shall be avoided]~~ in **the** design of landscape improvements **must be avoided** by considering the size and breadth of mature landscaping. ~~[Show existing]~~ **Existing** and proposed **signage,** overhead and underground power lines, utility poles, light standards and utility easements **must be shown** on submitted landscape plans. Fire hydrants, fire connections, water boxes ~~[(3 feet clearance required),]~~, water and sewer service lines ~~[10 feet clearance required for trees,]~~, overhead utilities, signs, roof ~~[overhangs, light standards etc., shall be taken into consideration]~~ **overhangs, light standards and similar items must be considered** in **the** design of landscaping. ~~[Show all proposed and existing signage for the site.]~~ **All shown water boxes must depict a clearance of 3 feet. All shown water and sewer service lines must depict 10 feet of clearance for trees.**

SECTION XXXX:

That Title 18 Appendix (CARSON CITY DEVELOPMENT STANDARDS), Division 3 (LANDSCAPING), Section 3.12 (Inspection, certifications and security) is hereby amended (**bold, underlined** text is added, ~~[stricken]~~ text is deleted) as follows:

3.12 Inspection, certifications and security.

- 3.12.1 Upon **the** installation of landscaping and irrigation systems, the registered design professional, licensed design professional, general contractor, certified landscape contractor, registered landscape ~~[architect, or others as allowed per Nevada Revised Statutes (NRS)]~~ **architect or any other professional authorized under state law and** who created, stamped and signed the landscaping and irrigation plans, or ~~[who has been authorized by that person, shall]~~ **his or her designee, must** certify that the installation was completed ~~[per]~~ **in accordance with** the approved plans, including **, without limitation, the** review of installation of correct plant materials, **that** planting was according to diagrams and instructions included in the ~~[plan,]~~ **plan and proper** emitter location, ~~[and detail, etc.]~~ A

letter attesting to ~~[this inspection and compliance shall be submitted to the planning division.]~~ **the installation in accordance with approved plans must be submitted to the Planning Division of the Department before a certificate of occupancy for the site may be issued.** Plant tags ~~[are to]~~ **must** be left on plants until after approval of the landscaping plan by the authorized professional and ~~[shall]~~ **must** be removed upon approval. The ~~[planning division retains the right to inspect projects, and if not]~~ **Planning Division of the Department may inspect projects for compliance. If the Planning Division determines that a project is** not in compliance with submitted plans, **the Division may** require **remediation for** compliance ~~[prior to issuance of]~~ **before** a final certificate of ~~[occupancy.]~~ **occupancy is issued.**

3.12.2 ~~[It is understood]~~ **The Board of Supervisors hereby recognizes** that minor deviations ~~[and/or]~~ **or** plant substitutions may be necessary during the course of the project. ~~[These]~~ **Such** deviations **and plant substitutions** may be ~~[done if approved by the registered design professional or others as allowed per NRS, and]~~ **approved** if **the deviation is** consistent with the original approved design, and **any** plants selected **as substitutions** are similar to the original plan and intended purpose. ~~[Notification in writing to the director is required for these instances. Approval is required from the director prior to installation.]~~ **The Director must be notified in writing of any request for a deviation or plant substitution and approval from the Director must be issued before installation.** Upon completion, as-built landscape plans ~~[shall be submitted.]~~ **must be submitted to the Department.** Major design revisions ~~[require a new fee and additional staff resources.]~~ **may be subject to an additional fee as established by the Department and approved by the Board of Supervisors.**

3.12.3 ~~[If, due to weather constraints, all]~~ **If** landscaping is not completed ~~[prior to the final inspection,]~~ **before final inspection as the result of weather constraints,** financial security in a form acceptable to the ~~[city]~~ **City and** in the amount of 150 percent of the estimated cost of installation of remaining landscape improvements ~~[shall]~~ **must** be filed with the ~~[city]~~ **City** guaranteeing installation within 9 months of final inspection. The estimated cost of the landscaping improvements not completed must be verified by the ~~[city.]~~ **City.** Installation of plant materials during ~~[times]~~ **periods** when the ground is likely to be frozen is discouraged ~~[due to]~~ **to avoid** high mortality of plants. ~~[Delay of planting, and providing financial security in a form acceptable to the city, as described in subsection 3.13.1, is recommended during these times.]~~

SECTION XXXX:

That Title 18 Appendix (CARSON CITY DEVELOPMENT STANDARDS), Division 3 (LANDSCAPING), Section 3.13 (Maintenance) is hereby amended (**bold,** **underlined** text is added, ~~[stricken]~~ text is deleted) as follows:

3.13 Maintenance.

3.13.1 All landscape areas must be maintained by the property owners, including using the most current pruning standards ~~[accepted by the ANSI International Society of~~

~~Arboriculture and/or the National Arborist Association.]~~ **The planting and maintenance of shrubs and trees must be done in accordance with the most current standards and best management practices adopted by the American National Standards Institute and the International Society of Arboriculture.** Any damaged or dead plant(s) must be

replaced or repaired by the property owners within 30 days following notification by the director. If the season of the year makes this repair or replacement within a 30 day period impractical, the person responsible for landscaping shall schedule an appropriate time for the completion of the accomplishment of this work as required and approved by the director. Property owner shall provide a financial security in a form acceptable to the city, in the amount of 150 percent of the estimated cost of installation of remaining landscape improvements, which shall be filed with the city guaranteeing installation. The estimated cost of the landscaping improvements not yet completed must be verified by the city.

3.13.2 Maintenance must include the checking of the sprinkler pattern and drip systems, plant condition, weeding, fertilization, pest control, replacement of mulches, weed barrier and dead material, or other debris, proper pruning and use of proper mowing heights. Radical pruning or trimming such as topping shall require replacement of the plant material.

The required maintenance schedule for both the planting and the irrigation system shall be shown on the landscape plan provided to the owner by the registered design professional or others as allowed by NRS.

3.13.3 An acknowledgment by the property owner of the required maintenance for a project must be submitted to the city as a part of landscape and irrigation plan submittals.

SECTION XXXX:

That Title 18 Appendix (CARSON CITY DEVELOPMENT STANDARDS), Division 3 (LANDSCAPING), Section 3.14 (Revisions to landscape plans) is hereby amended (**bold, underlined** text is added, [~~stricken~~] text is deleted) as follows:

3.14 Revisions to landscape plans.

3.14.1 If a revision to a landscape plan results in a change to the approved plans of more than 25 percent, a new landscape plan and review fee are required. Variations to the plan include, but are not limited to, change in species, type (e.g. rock, mulch, turf, etc.), and change in location.

SECTION XXXX:

That Title 18 Appendix (CARSON CITY DEVELOPMENT STANDARDS), Division 3 (LANDSCAPING), Section 3.15 (Design standards) is hereby repealed (**bold, underlined** text is added, [~~stricken~~] text is deleted) as follows:

3.15 Design standards.

[Diagrams, text and examples are located in the appendix, including, but not limited to, general landscape and irrigation notes, irrigation legend detail, typical plant list legend example, tree and shrub planting details, emitter layout and staking, bubbler, tree protection, flushing end cap, drip, spray and coupling valves, rotor/pop up head, irrigation trench wall section, rock wall, wood and pipe bollards, approved tree, shrub, riparian and historic district lists, pruning, tree retention/protection, root pruning and excavation adjacent to retained tree details.

Appendix.

GENERAL LANDSCAPE NOTES:			02/2007	
<p>ALL LAWN AREAS SHALL BE CONTOURED AND ROLLED WITH A WEIGHTED HAND ROLLER PRIOR TO SOODING OPERATIONS.</p> <p>CONTRACTOR MAY PROVIDE PHOTOGRAPHS OR SAMPLES OF ALL TREE PLANT MATERIAL FOR APPROVAL BY THE DESIGN PROFESSIONAL OR OWNER'S REPRESENTATIVE TO SEE IF SPECIFICATIONS ARE MET. THIS DOES NOT GUARANTEE ACCEPTANCE OF ALL TREES UPON DELIVERY TO PROJECT SITE.</p> <p>THE CONTRACTOR IS RESPONSIBLE FOR LOCATING ALL UNDERGROUND UTILITIES PRIOR TO ANY DIGGING OR CONSTRUCTION. THE ACQUISITION OF ALL NECESSARY PERMITS ASSOCIATED WITH CONSTRUCTION SHALL BE THE CONTRACTOR'S RESPONSIBILITY.</p> <p>THE CONTRACTOR SHALL BE RESPONSIBLE FOR READING ALL NOTES, CHECKING PLANT NAMES AND CONFIRMING ALL NUMBERS, SIZES, AND PLANT AVAILABILITY PRIOR TO SUBMITTING BID.</p> <p>IF QUANTITIES LISTED IN THE PLANTING SCHEDULES DO NOT CORRELATE WITH THE QUANTITIES INDICATED ON THE PLANS, THEN PLAN QUANTITIES SHALL GOVERN.</p> <p>THE CONTRACTOR SHALL FURNISH ALL LABOR, MATERIALS, EQUIPMENT AND SERVICES NECESSARY TO INSTALL ALL MATERIALS COMPLETE AND IN PLACE AS SHOWN AND/OR SPECIFIED.</p> <p>FINISH GRADES IN ALL LAWN AREAS SHALL BE ESTABLISHED BEFORE INSPECTION BY THE DESIGN PROFESSIONAL OR OWNER'S REPRESENTATIVE PRIOR TO INSTALLATION OF SOD.</p> <p>ROUGH GRADE, FINISH GRADE AND ALL BERM LOCATION/SHAPES SHALL BE ESTABLISHED BY THE CONTRACTOR AND APPROVED BY THE LANDSCAPE ARCHITECT, DESIGN PROFESSIONAL OR OWNER'S REPRESENTATIVE BEFORE INSTALLATION OF THE IRRIGATION SYSTEM, SITE ELEMENTS OR ANY SOD.</p> <p>SOIL AMENDMENTS IN COMPLIANCE WITH DEVELOPMENT STANDARDS 3.11 SHALL BE INCORPORATED INTO THE TOP 8" TO 10" (MIN.) OF THE ROUGH GRADE OF ALL LAWN AREAS PRIOR TO SOODING.</p> <p>ROUGH GRADE IN ALL LAWN AND PLANTING BED AREAS SHALL BE SCARIFIED TO A MINIMUM DEPTH OF 8"-10" (MIN.) PRIOR TO INSTALLATION OF PLANT MATERIAL, BERMS AND SOD.</p> <p>ALL SOD AND PLANT MATERIALS SHALL BE #1 GRADE NURSERY STOCK AND WARRANTED FOR ONE YEAR AFTER FINAL PROJECT ACCEPTANCE. REPLACE ANY PLANT WHICH DIES WITHIN 30 DAYS AFTER NOTIFICATION, EXCEPT DURING WINTER, WHEN REPLANTING MAY BE DELAYED, WITH PLANTS EQUAL TO ORIGINAL MATERIALS.</p> <p>THE CONTRACTOR SHALL BE REQUIRED TO EXCAVATE ALL LAWN & PLANTING BED AREAS TO ESTABLISH ROUGH GRADE AND INSTALL REQUIRED SOIL AMENDMENTS. (4 1/2" BELOW TOP OF CURBS IN PLANTING AREAS & 1 1/2" BELOW SIDEWALKS IN LAWN AREAS.)</p> <p>ANY IMPORTED TOPSOIL REQUIRED FOR INSTALLATION OF THE BERMS OR ESTABLISHMENT OF ROUGH GRADE OR FINISH GRADE SHALL BE TOPSOIL MIX APPROVED BY THE LANDSCAPE ARCHITECT OR DESIGN PROFESSIONAL PRIOR TO INSTALLATION.</p> <p>TREE STAKING SHALL BE DONE ON ALL TREES. CONTRACTOR SHALL STAKE AS PER DETAIL. ORIGINAL NURSERY STAKES ON TREES SHALL BE REMOVED BEFORE INSTALLATION. TREES MUST STAND UPRIGHT WITHOUT SUPPORT TO BE ACCEPTABLE.</p> <p>INSTALL A PROFESSIONAL GRADE LANDSCAPE FABRIC UNDER ALL ROCK MULCH AREAS. SECURE TO ROUGH GRADE. DO NOT LEAVE EXPOSED. (SEE DEV ST 3.11) NO PLASTIC SHEETING CAN BE PLACED UNDER ROCK MULCH</p> <p>ROCK MULCH SHALL BE WASHED AND CLEANED. MULCH DEPTH TO BE 4"-6" MIN. AND BE INSTALLED IN ALL PLANTING AREAS AND OVER ALL BERMS AS SHOWN ON APPROVED LANDSCAPE PLANS. WEED FABRIC SHOULD BE COVERED BY MULCH AND NOT VISIBLE.</p> <p>ALL PLANTING PITS SHALL BE EITHER HAND OR BACKHOE DUG (NO AUGER). THE BOTTOM AND SIDES OF THE PLANTING PITS SHALL BE SCARIFIED BEFORE INSTALLATION OF THE PLANT MATERIAL. HOLES SHALL BE THREE TIMES AS WIDE AS THE ROOTBALL DIAMETER, THE SAME DEPTH AS THE ROOTBALL AND BACKFILLED WITH AN APPROVED SOIL MIX.</p> <p>ALL PLANTING BEDS AND SOD AREAS SHALL BE STRIPPED AND CLEARED OF ALL LAWN, ROOTS, WEEDS, AND DEBRIS AND SHALL BE RAKED TO A SMOOTH AND EVEN GRADE PRIOR TO PLANT MATERIAL OR SOD INSTALLATION.</p>				
SCALE: NTS				
NO.	REVISION	DATE	Standard Landscape Detail	
			<p>GENERAL LANDSCAPE NOTES</p>	
			<p>File Name: (D:\landscape\detail\LANDSCAPE NOTES.dwg)</p> <p>Landscape Detail Number: L-XX</p> <p>Date: 02/2007 Page: 1a</p>	

INSTALL IBDU WATER SOLUBLE STARTER PLANT FERTILIZER BAGS/TABLETS OR AN APPROVED EQUAL IN ALL PLANTING PITS. USE 1 PER 1-GALLON CONTAINER, 3 PER 5-GALLON CONTAINER, AND 5 PER 15-GALLON CONTAINER/ 2" CAL. OR LARGER TREE.

CONTRACTOR TO APPLY A PRE-EMERGENT HERBICIDE AND PERMEABLE LANDSCAPE FABRIC THROUGHOUT ALL ROCK MULCH AREAS PRIOR TO PLACING MULCH. NO PRE-EMERGENT HERBICIDE SHALL BE APPLIED IN PERENNIAL, GROUND COVER, BULB AND ANNUAL AREAS. ADD GRANULAR PRE-EMERGENT HERBICIDE PER MANUFACTURER'S WRITTEN RECOMMENDATIONS PRIOR TO INSTALLING LANDSCAPE FABRIC AND ROCK MULCH.

FINAL LOCATION OF ALL LANDSCAPE PLANT MATERIAL SHALL BE SET BY THE CONTRACTOR ACCORDING TO THE PLANS AND APPROVED BY THE LANDSCAPE ARCHITECT, DESIGN PROFESSIONAL OR OWNER'S REP BEFORE INSTALLATION.

NO PLANTS SHALL BE PLACED TO CONFLICT OR CREATE CONFLICT W/ SIGNS, LIGHTS, UTILITIES, ETC. IF PLANT LOCATION WILL CAUSE A CONFLICT, CONTACT THE LANDSCAPE ARCHITECT.

ALL PERENNIAL & GROUND COVER AREAS SHALL BE HAND SET BY THE CONTRACTOR IN AREAS SHOWN ON DRAWINGS AND APPROVED BY THE LANDSCAPE ARCHITECT, DESIGN PROFESSIONAL OR OWNER'S REP BEFORE INSTALLATION.

THE CONTRACTOR SHALL REMOVE ALL BURLAP, TWINE, TIES, CONTAINERS AND WIRE BASKETS FROM ALL PLANT MATERIAL. DO NOT DISTURB ROOTBALLS. REMOVE ANY EXCESS SOIL ON TREES OR SHRUBS THAT HAS ACCUMULATED DURING THE PACKAGING & SHIPPING PROCESS, (B&B STOCK - ESPECIALLY) IN ORDER TO DETERMINE PROPER PLANTING DEPTH IN ORDER TO PLACE ROOTBALL AT 1" ABOVE GRADE. CLEAN DOWN TO THE TOP OF STRUCTURAL (FLARED) ROOT SYSTEM.

THE CONTRACTOR SHALL TAKE ALL NECESSARY PRECAUTIONS TO PROVIDE EFFECTIVE DUST CONTROL OF ALL PREPARED SOIL AREAS.

ALL TREES TO BE #1 GRADE NURSERY STOCK AND MEET CURRENT INDUSTRY QUALITY STANDARDS ADOPTED BY THE AMERICAN ASSOCIATION OF NURSERYMEN, AMERICAN NATIONAL STANDARDS INSTITUTE (ANSI) Z60 AND NEVADA REVISED STATES (NRS) 555 (REGULATIONS OF NURSERY AND NURSERY STOCK). ALL TREES MUST COMPLY WITH:

- NO GIRDLING, KINKED, CIRCLING OR "J" ROOTS.
- NO TREES THAT HAVE BEEN TOPPED.
- NO WOUNDS IN THE TRUNK BARK OR ON LIMBS.
- INSECT AND DISEASE FREE, RODENT AND MECHANICAL DAMAGE FREE.
- NO TREES THAT HAVE LARGE NURSERY STAKES THROUGH ROOTBALL OR HAVE BEEN GROWN ON A NURSERY STAKE.
- ROOTBALL TO BE APPROPRIATE TO CALIPER AND CROWN SIZE.
- TRUNK/ CROWN STRUCTURE AND TRUNK TAPER TO BE APPROPRIATE FOR THE SPECIES.
- ALL GRAFT UNIONS TO BE HEALTHY WITH TRUNK DIAMETER BELOW UNION LARGER THAN ABOVE UNION.
- ALL TREES TO STAND UPRIGHT WITHOUT STAKES.
- ROOTS, BARK AND SHOOT GROWTH TO GIVE EVIDENCE OF GOOD TREE VIGOR.
- ANY REPLACEMENT OF PLANT STOCK TO BE EQUAL TO ORIGINAL SPECIFICATION AND APPROVED BY THE OWNER'S REPRESENTATIVE OR DESIGN PROFESSIONAL AND THE COMMUNITY DEVELOPMENT PLANNING DEPARTMENT.

ALL PLANTING BEDS AND SOD AREAS SHALL HAVE POSITIVE DRAINAGE AWAY FROM ALL BUILDINGS.

ALL BOX TREES TO BE STAKE FREE NURSERY STOCK, NO LARGE STAKES THROUGH ROOTBALL.

THE CONTRACTOR SHALL SPACE PLANT MATERIALS TO ACCOMMODATE EVERGREEN TREE GROWTH. SPACE ALL SHRUBS/ GROUND COVERS/ PERENNIALS A MINIMUM OF 8' AWAY FROM ANY EVERGREEN TREE TRUNK.

ANY SUBSTITUTION OF PLANT MATERIAL MUST BE SUBMITTED IN WRITING FOR APPROVAL BY THE LANDSCAPE ARCHITECT OR DESIGN PROFESSIONAL AND THE COMMUNITY DEVELOPMENT DEPARTMENT.

THE CONTRACTOR SHALL INSPECT THE SITE REGULARLY TO REVIEW THE CONDITION OF ALL PLANTINGS. IF ANY CHANGES IN THE OVERALL MAINTENANCE PROGRAM ARE REQUIRED TO IMPROVE THE CONDITIONS TO AN ACCEPTABLE STANDARD, THE CONTRACTOR SHALL NOTIFY THE OWNER IN WRITING. OTHERWISE THE CONTRACTOR ACCEPTS FULL RESPONSIBILITY FOR THE CONDITION OF THE PLANTINGS AND MUST HONOR THE GUARANTEE. ANY PLANTS REPLACED UNDER THIS GUARANTEE SHALL BE GUARANTEED FOR ONE FULL YEAR FROM THE DATE OF REPLACEMENT.

THE CONTRACTOR SHALL BE REQUIRED TO PROVIDE MAINTENANCE OF THE ENTIRE IRRIGATION SYSTEM & ALL LANDSCAPING UNTIL FINAL PROJECT ACCEPTANCE. AFTER FINAL PROJECT ACCEPTANCE ALL PROJECT MAINTENANCE SHALL BE THE RESPONSIBILITY OF THE OWNER.

THE CONTRACTOR SHALL TOP DRESS ROUGH GRADE OF ALL LAWN AREAS WITH 2" OF PROFESSIONAL GRADE TOP SOIL MIX, APPROVED BY THE LANDSCAPE ARCHITECT OR DESIGN PROFESSIONAL. SCARIFY ALL LAWN AREAS INCORPORATING TOPSOIL INTO ROUGH GRADE.

SCALE: NTS

NO.			REVISION		DATE	Standard Landscape Detail		File Name:	
GENERAL LANDSCAPE NOTES						[X:\landscape detail\LANDSCAPE NOTES.dwg]			
						Landscape Detail Number:			
						L-XX			
						Date: 02/2007	Page: 1b		

UPON INSTALLATION OF LANDSCAPING AND THE IRRIGATION SYSTEM, THE REGISTERED DESIGN PROFESSIONAL OR LANDSCAPE ARCHITECT OR OTHERS AS ALLOWED PER NRS SHALL CERTIFY THAT THE INSTALLATION WAS COMPLETED PER THE APPROVED PLANS. THE REGISTERED DESIGN PROFESSIONAL SHALL CHECK THE INSTALLATION TO VERIFY COMPLIANCE WITH APPROVED PLANS. THEN THE PLANNING DEPARTMENT SHALL INSPECT FOR FINAL APPROVAL. PLANT SPECIES IDENTIFICATION TAGS ARE TO BE LEFT ON PLANTS UNTIL AFTER APPROVAL OF THE LANDSCAPING AND THEN REMOVED.

IT IS UNDERSTOOD THAT MINOR DEVIATION AND/OR PLANT SUBSTITUTIONS MAY BE NECESSARY DURING THE COURSE OF THE PROJECT. THESE DEVIATIONS MAY BE DONE IF APPROVED BY THE LANDSCAPE ARCHITECT OR DESIGN PROFESSIONAL OR OTHERS AS ALLOWED PER NRS, AND IF CONSISTENT WITH THE ORIGINAL APPROVED DESIGN AND PLANTS SELECTED ARE SIMILAR TO THE ORIGINAL PLAN AND INTENDED PURPOSE. NOTIFICATION IN WRITING TO THE COMMUNITY DEVELOPMENT PLANNING DEPARTMENT IS REQUIRED FOR THESE INSTANCES. APPROVAL IS REQUIRED FROM THE DIRECTOR PRIOR TO INSTALLATION. UPON COMPLETION, AS-BUILT LANDSCAPE PLANS SHALL BE SUBMITTED TO COMMUNITY DEVELOPMENT PLANNING DEPARTMENT. MAJOR DESIGN REVISIONS MAY REQUIRE NEW FEES AND ADDITIONAL STAFF RESOURCES.

ALL LANDSCAPE AREAS MUST BE MAINTAINED BY THE PROPERTY OWNERS, INCLUDING USING THE MOST CURRENT PRUNING STANDARDS ACCEPTED BY THE INTERNATIONAL SOCIETY OF ARBORICULTURE AND/OR THE NATIONAL ARBORIST ASSOCIATION. ANY DAMAGED OR DEAD PLANT MUST BE REPLACED OR REPAIRED BY THE PROPERTY OWNERS WITHIN 30 DAYS FOLLOWING NOTIFICATION BY THE DIRECTOR. IF THE SEASON OF THE YEAR MAKES THIS REPAIR OR REPLACEMENT WITHIN A 30 DAY PERIOD IMPRACTICAL, THE PERSON RESPONSIBLE FOR LANDSCAPING SHALL SCHEDULE AN APPROPRIATE TIME FOR THE COMPLETION OF THE ACCOMPLISHMENT OF THIS WORK AS REQUIRED BY THE DIRECTOR.

MAINTENANCE MUST INCLUDE THE CHECKING OF THE SPRINKLER PATTERN AND DRIP SYSTEMS, PLANT CONDITION, WEEDING, FERTILIZATION, PEST CONTROL, REPLACEMENT OF MULCHES, WEED BARRIER AND CLEAR AWAY DEBRIS, PROPER PRUNING AND USE OF PROPER MOWING HEIGHTS. RADICAL PRUNING OR TRIMMING SUCH AS AS TOPPING SHALL REQUIRE REPLACEMENT OF THE PLANT MATERIAL.

SCALE: NTS

NO.			REVISION			DATE			Standard Landscape Detail			File Name:					
GENERAL LANDSCAPE NOTES												[H:\landscape_detail\LANDSCAPE_NOTES.dwg]					
												Landscape Detail Number:			L-XX		
												Date: 02/2007			Page: 1c		

GENERAL IRRIGATION NOTES:

2/2007

ALL PLUMBING AND ELECTRICAL WORK SHALL BE COMPLETED AS PER ALL LOCAL CODES.

INSTALLATION OF MATERIALS SHALL BE PER MANUFACTURERS RECOMMENDATIONS OR AS SPECIFIED. SPRINKLER HEADS ARE EXACT. NO EXTRA PAYMENT WILL BE MADE WHERE PIPING MUST BE OFFSET TO AVOID EXISTING CONDITIONS, OTHER WORK OR WHERE CHANGES ARE NECESSARY TO FACILITATE INSTALLATION.

THE IRRIGATION SYSTEM SHALL BE CONSTRUCTED FOR WINTERIZATION BY THE CONTRACTOR.

ALL MATERIALS SHALL BE NEW, WITHOUT FLAWS AND CONSIDERED THE BEST AVAILABLE IN STOCK. THE COMPLETE SYSTEM SHALL HAVE A ONE-YEAR WARRANTY AFTER FINAL PROJECT ACCEPTANCE ON ALL PARTS AND LABOR.

PRIOR TO FINAL PROJECT ACCEPTANCE, THE CONTRACTOR SHALL INSTRUCT THE OWNER, OR HIS REPRESENTATIVE, IN THE PROPER OPERATION, MAINTENANCE, AND WINTERIZATION OF THE ENTIRE IRRIGATION SYSTEM.

THE CONTRACTOR SHALL PROVIDE AND KEEP CURRENT A COMPLETE SET OF RECORD DRAWINGS WHICH SHALL BE CORRECTED DAILY TO SHOW CHANGES IN THE ORIGINAL DRAWINGS. ALL MAINLINE PIPING AND VALVE LOCATIONS SHALL BE SHOWN WITH ACTUAL MEASUREMENTS TO REFERENCE POINTS.

WHEN THE SYSTEM IS COMPLETE, THE CONTRACTOR SHALL PERFORM A COVERAGE TEST. THE IRRIGATION SYSTEM SHALL PROVIDE 100% COVERAGE OF ALL LAWN & LANDSCAPE PLANTING AREAS.

ALL IRRIGATION MAINLINE PIPING & LATERAL PIPING SHALL BE SCHEDULE 40 PVC PIPE.

THE CONTRACTOR SHALL BE RESPONSIBLE FOR ANY SETTLING IN THE IRRIGATION TRENCHES OR ASSOCIATED IRRIGATION WORK AS A WARRANTY ITEM.

ALL IRRIGATION VALVES SHALL BE LOCATED IN PROFESSIONAL GRADE VALVE BOXES. SIZE OF VALVE BOXES SHALL VARY WITH NUMBER OF VALVES LOCATED IN BOX. ALL VALVE BOX LID ELEVATIONS SHALL BE SET FLUSH WITH FINISHED GRADE. PROVIDE BOX SIZE THAT WILL ALLOW 6" CLEARANCE AROUND ALL SIDES OF VALVES. PROVIDE BOLTS PER MANUFACTURER'S RECOMMENDATIONS AND SECURE EACH VALVE BOX.

ON ALL THREADED JOINTS WITHIN THE IRRIGATION SYSTEM, THE CONTRACTOR SHALL USE 2-3 FULL TURNS OF TEFLON TAPE AT EACH CONNECTION.

WIRE CONNECTORS SHALL BE USED ON ALL FIELD WIRE SPLICES AND CONNECTIONS.

ALL CONTROL WIRE SHALL BEAR A U/L APPROVED LABEL FOR DIRECT UNDERGROUND BURIAL IN NATIONAL ELECTRIC CODE CLASS IT CIRCUITS. AWG SIZES. ALL CONTROL WIRE RUNS LESS THAN 1000' SHALL HAVE NO SPLICES. IF A SPLICE OCCURS ON A FIELD CONTROL WIRE, THE CONTRACTOR SHALL INSTALL THE SPLICE IN A 6" ROUND VALVE BOX USING APPROVED WATERTIGHT CONNECTORS. IF APPROVED BY THE LANDSCAPE ARCHITECT OR DESIGN PROFESSIONAL. OTHERWISE THE ENTIRE FIELD CONTROL WIRE SHALL BE REMOVED & REPLACED.

TAPE AND BUNDLE ALL CONTROL WIRE TO BOTTOM OF MAINLINE PIPE AT 10' O.C.

THE IRRIGATION CONTROLLER SHALL BE INSTALLED IN A LOCATION AS SHOWN ON THE PLANS. THE LANDSCAPE ARCHITECT, DESIGN PROFESSIONAL, OR THE OWNER'S REPRESENTATIVE WILL APPROVE FINAL CONTROLLER LOCATION.

SCALE: NTS

NO.			REVISION			DATE			Standard Irrigation Detail			File Name:	
									GENERAL IRRIGATION NOTES			[E:\landscape_details\IRRIGATION NOTES.dwg]	
												Landscape Detail Number:	
												L-XX	
												Date: 2/2007	Page: 2a

IRRIGATION VALVE BOXES ARE TO BE INSTALLED IN LANDSCAPE PLANTING AREAS OR OTHER PROTECTED SPACES. VALVE BOXES SHALL NOT BE INSTALLED IN LAWN AREAS.

THE CONTRACTOR SHALL INSTALL SCHEDULE 40 GALVANIZED PIPING 5' ON EITHER SIDE OF THE BACK FLOW PREVENTER, AS DEPICTED IN THE STANDARD CITY'S DETAIL.

FILTER FABRIC FOR ABOVE ALL ROCK SUMPS SHALL BE PROFESSIONAL GRADE WEED BARRIER OR AN APPROVED EQUAL.

IRRIGATION MAINLINE TO BE BURIED 24" BELOW FINISHED GRADE AND ALL SPRAY SYSTEM LATERAL LINE PIPING TO BE BURIED 18" BELOW FINISH GRADE. ALL 3/4" DRIP IRRIGATION TUBING TO BE BURIED 4" - 6" BELOW FINISH GRADE.

THE CONTRACTOR IS RESPONSIBLE FOR LOCATING ALL UNDERGROUND UTILITIES PRIOR TO ANY CONSTRUCTION. THE ACQUISITION OF ALL NECESSARY PERMITS ASSOCIATED WITH CONSTRUCTION SHALL BE THE CONTRACTORS RESPONSIBILITY.

ALL GALVANIZED PIPE IN CONTACT WITH SOIL SHALL BE COVERED WITH PVC TAPE TO PREVENT PIPE CORROSION (PER UNIFORM PLUMBING CODE).

THE CONTRACTOR SHALL INSTALL A CURB STOP AND WASTE VALVE AT THE BACKFLOW PREVENTER (SIZE TO MATCH MAINLINE) (AS PER CITY'S PUBLIC WORKS DEPARTMENT DETAIL).

PIPE DOPE SHALL NOT BE USED ANYWHERE ON THE IRRIGATION SYSTEM.

NO 3/4" PIPE SHALL BE USED ANYWHERE ON THE SPRAY IRRIGATION SYSTEM. (EXCEPT FOR 3/4" SWING JOINT ASSEMBLIES FOR ROTOR OR POP-UP SPRAY HEADS).

THE CONTRACTOR SHALL EXPOSE ENDS OF ALL IRRIGATION SLEEVES. ANY BROKEN OR SHATTERED ENDS OF THE IRRIGATION SLEEVES SHALL BE CUT TO A CLEAN END BEFORE INSTALLATION OF EITHER MAINLINE PIPE, LATERAL LINES OR DRIP IRRIGATION TUBING. ALL SLEEVE ENDS SHALL BE INSPECTED BY THE LA/DESIGN PROFESSIONAL BEFORE BURYING.

FINAL CONNECTION OF THE VALVE WIRES TO THE CONTROLLER SHALL BE THE CONTRACTOR'S RESPONSIBILITY.

THE CONTRACTOR SHALL AT HIS OWN EXPENSE, LOCATE ALL UNDERGROUND UTILITIES WHICH MAY EFFECT HIS OPERATION DURING CONSTRUCTION AND SHALL TAKE ALL NECESSARY PRECAUTIONS TO AVOID DAMAGE TO THE SAME.

THE CONTRACTOR SHALL USE EXTREME CAUTION WHEN WORKING NEAR OVERHEAD OR UNDERGROUND POWER AND/OR TELEPHONE, WATER, GAS AND SEWER FACILITIES SO AS TO SAFELY PROTECT ALL UTILITIES, PERSONNEL, AND EQUIPMENT, AND SHALL BE RESPONSIBLE FOR ALL COSTS AND LIABILITY IN CONNECTION THEREWITH.

THE CONTRACTOR SHALL TAKE ALL PRECAUTIONARY MEASURES NECESSARY TO PROTECT EXISTING IMPROVEMENTS WHICH ARE TO REMAIN IN PLACE, FROM DAMAGE, AND ALL SUCH IMPROVEMENTS DAMAGED BY THE CONTRACTOR'S OPERATIONS SHALL BE REPAIRED OR RECONSTRUCTED TO THE OWNER'S SATISFACTION AT THE CONTRACTOR'S EXPENSE.

ALL MAINLINES SHALL BE PRESSURE TESTED AT 1.5 TIMES THE STATIC PRESSURE FOR A MINIMUM 2 HOUR PERIOD PRIOR TO BACKFILLING OF TRENCHES. TEST WILL BE CONSIDERED SUCCESSFUL IF NO PRESSURE LOSS OCCURS DURING THE TWO HOURS. IF ANY LEAKS ARE PRESENT THEY SHALL BE CORRECTED AND LINES SHALL BE RE-TESTED PRIOR TO BACKFILLING TRENCHES.

SCALE: NTS

NO.	REVISION	DATE	Standard Irrigation Detail	File Name:
			GENERAL IRRIGATION NOTES	[H:\landscape details\IRRIGATION NOTES.dwg]
				Landscape Detail Number: L-XX
				Date: 2/2007 Page: 2b

PIPE SIZES SHALL CONFORM TO THOSE SHOWN ON THE DRAWINGS. NO SUBSTITUTIONS OF SMALLER PIPE SIZES SHALL BE PERMITTED, BUT SUBSTITUTIONS OF LARGER SIZES MAY BE APPROVED. ALL DAMAGED AND REJECTED PIPE SHALL BE REMOVED FROM THE SITE AT THE TIME OF SAID REJECTION.

THE CONTRACTOR SHALL FLUSH ALL LATERALS AND EMITTER LINES PRIOR TO INSTALLING EMITTERS.

IT IS THE RESPONSIBILITY OF THE CONTRACTOR TO FAMILIARIZE HIMSELF WITH ALL GRADE DIFFERENCES, LOCATION OF WALLS, STRUCTURES AND UTILITIES. THE IRRIGATION CONTRACTOR SHALL REPAIR OR REPLACE ALL ITEMS DAMAGED BY HIS WORK. HE SHALL COORDINATE HIS WORK WITH OTHER CONTRACTORS, FOR THE LOCATION AND INSTALLATION OF PIPE SLEEVES AND LATERALS UNDER SIDEWALKS AND PAVING.

SHOULD DISCREPANCIES ARISE BETWEEN THESE PLANS AND ACTUAL FIELD CONDITIONS WHICH REQUIRE FIELD MODIFICATIONS OR PLAN REVISIONS, THE LANDSCAPE ARCHITECT, DESIGN PROFESSIONAL, OR OWNER'S REPRESENTATIVE SHALL BE CONTACTED PRIOR TO CONSTRUCTION FOR RESOLUTION OR PLAN REVISION.

DO NOT WILLFULLY INSTALL THE IRRIGATION SYSTEM AS SHOWN ON THE DRAWINGS WHEN IT IS OBVIOUS IN THE FIELD THAT UNKNOWN OBSTRUCTIONS, GRADE DIFFERENCES OR DIFFERENCES IN THE AREA DIMENSIONS EXIST THAT MIGHT NOT HAVE BEEN CONSIDERED IN THE DESIGN. SUCH OBSTRUCTIONS OR DIFFERENCES SHOULD BE BROUGHT TO THE ATTENTION OF THE LANDSCAPE ARCHITECT, DESIGN PROFESSIONAL, OR THE OWNERS REPRESENTATIVE. IN THE EVENT THIS NOTIFICATION IS NOT PERFORMED, THE CONTRACTOR SHALL ASSUME FULL RESPONSIBILITY FOR ANY REVISIONS NECESSARY.

THE IRRIGATION CONTROLLER SHALL BE WIRED DIRECTLY TO A 110 VOLT POWER SOURCE. IT SHALL BE THE RESPONSIBILITY OF THE CONTRACTOR TO PROVIDE IRRIGATION CONTROLLER WIRING TO THE POWER SOURCE. CONNECTING THE CONTROLLER TO THE POWER SOURCE SHALL BE THE RESPONSIBILITY OF A LICENSED ELECTRICAL CONTRACTOR. THE INSTALLATION SHALL BE IN ACCORDANCE WITH THE NATIONAL ELECTRICAL CODE AND ANY LOCAL CODES OR ORDINANCES THAT APPLY. IT SHALL BE THE ELECTRICAL CONTRACTOR'S RESPONSIBILITY TO COORDINATE THE POWER SOURCE AND EXACT LOCATION OF THE CONTROLLER WITH OWNER'S REPRESENTATIVE.

SCALE: NTS

NO.			REVISION			DATE			Standard Irrigation Detail			File Name:	
									GENERAL IRRIGATION NOTES			[H:\landscape details\IRRIGATION NOTES.dwg]	
												Landscape Detail Number:	
												L-XX	
												Date: 2/2007	Page: 2c

TYPICAL PLANT LIST EXAMPLE				
TREE LEGEND				
QUANTITY	SYMBOL	COMMON/ BOTANICAL NAME	SIZE	SPACING
9	A	CHANTICLEER FLOWERING PEAR <i>Pyrus calleryana</i> 'Chanticleer'	2" CAL	40 FEET ON CENTER
4	B	BLOODGOOD JAPANESE MAPLE <i>Acer palmatum</i> 'Bloodgood'	2" CAL	AS PER PLANS
16	C	NORTHERN RED OAK <i>Quercus rubra</i>	2" CAL	40 FEET ON CENTER
5	D	BLUE ASH <i>Fraxinus quadrangulata</i>	2" CAL	40 FEET ON CENTER
3	E	BACHERI BLUE SPRUCE <i>Picea pungens</i> 'Baehari'	6" TALL (MIN.)	15 FEET ON CENTER
1	F	BLUE HAVEN JUNIPER <i>Juniperus scopulorum</i>	6" TALL (MIN.)	8 FEET ON CENTER

TYPICAL PLANT LIST EXAMPLE				
SHRUB/ PERENNIAL LEGEND				
QUANTITY	SYMBOL	COMMON/ BOTANICAL NAME	SIZE	SPACING
120	AA	JAPANESE REDLEAF BARBERRY <i>Barberry thunbergii</i> 'Atropurpurea'	5 GAL.	6 FEET ON CENTER
15	BB	ROCK COTONEASTER <i>Cotoneaster horizontalis</i>	5 GAL.	6 FEET ON CENTER
207	CC	DWARF OREGON GRAPE <i>Mahonia aquifolium</i> 'Compacta'	5 GAL.	4 FEET ON CENTER
109	DD	SUTTER'S GOLD POTENTILLA <i>Potentilla fruticosa</i> 'Sutter's Gold'	5 GAL.	4 FEET ON CENTER
11	EE	VANHOUTTE SPIREA <i>Spiraea vanhouttei</i>	5 GAL.	6 FEET ON CENTER
3	FF	DWARF MUGHO PINE <i>Pinus mugo</i> 'mugo'	5 GAL.	5 FEET ON CENTER
55	GG	RED-HOT POKER <i>Kniphofia uvaria</i>	1 GAL.	3 FEET ON CENTER
30	HH	MOONBEAM COREOPSIS <i>Coreopsis lanceolata</i> 'Moonbeam'	1 GAL.	2 FEET ON CENTER
27	II	DAY LILIES (MIXED COLORS) <i>Hemerocallis</i> spp.	1 GAL.	3 FEET ON CENTER
24	JJ	BALTIM IVY <i>Hedera helix</i> 'Baltica'	1 GAL.	18 INCHES ON CENTER

SCALE: NTS

NO.	REVISION	DATE	Standard Landscape Detail	File Name:
			TYPICAL PLANT LIST	[H:\Landscape details\PLANTING LEGEND.dwg]
				Landscape Detail Number: L-XX
				Date: 5/2006 Page: 3

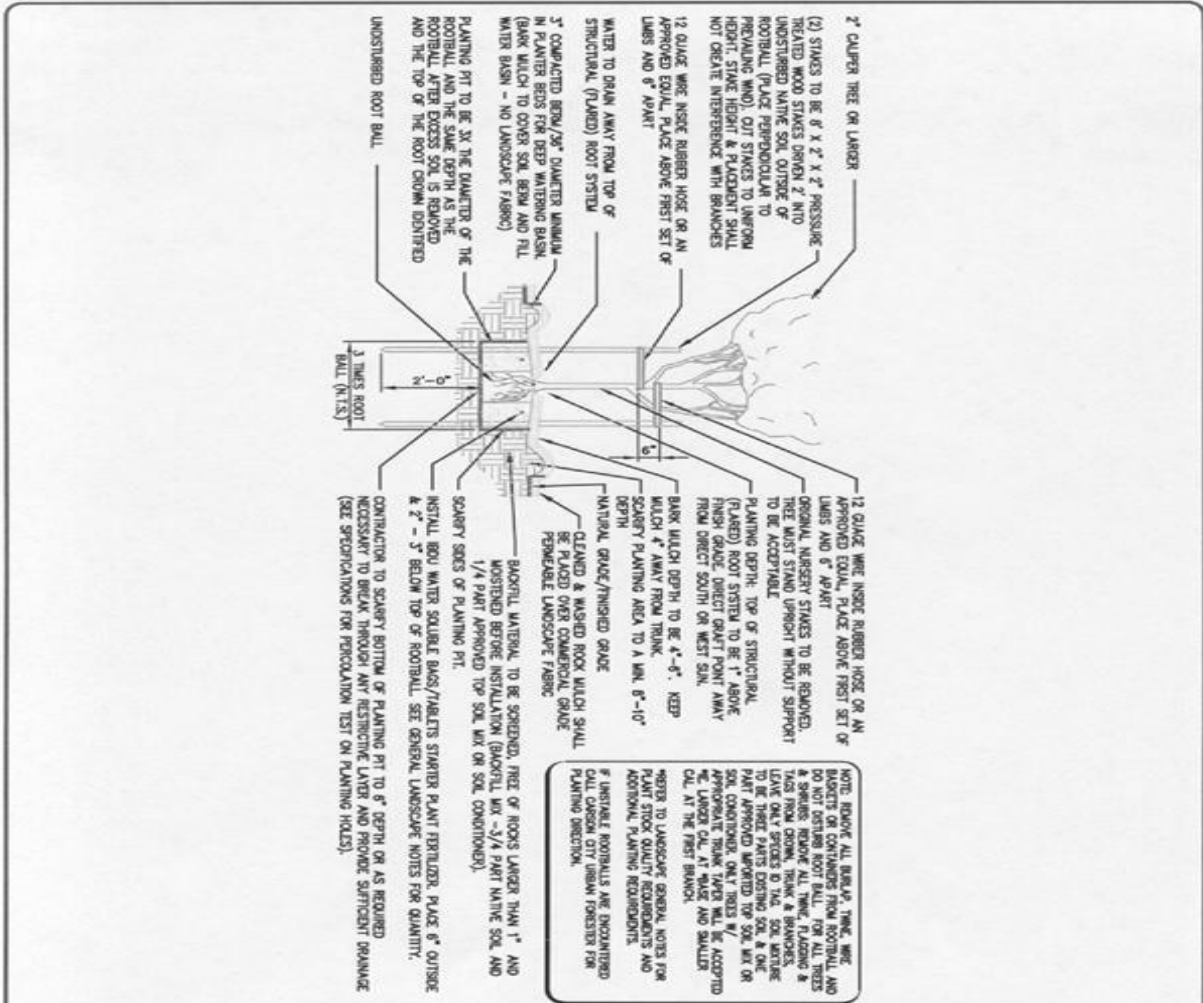

SCALE: NTS

Standard Landscape Detail			File Name:
NO.	REVISION	DATE	[14:landscape details\l2706.dwg]
			Landscape Detail Number: L-XX
			Date: 2/2007 Page: 4

DECIDUOUS TREE

TYPICAL PLANTING DETAIL IN LANDSCAPE AREAS

NOTE: REMOVE ALL BIRAP, TRIM, WIRE BASKETS OR CONTAINERS FROM ROOTBALL AND DO NOT DISTURB ROOT BALLS FOR ALL TREES & SPECIES. REMOVE ALL TRUNK FLUDDING & TAGS FROM GROWN TRUNK & BRANCHES. LEAVE ONLY SPECIES ID TAG, SOIL MIXTURE TO BE THREE PARTS EXISTING SOIL AND ONE PART APPROVED IMPORTED TOP SOIL MIX OR SOIL CONDITIONER.

REFER TO LANDSCAPE GENERAL NOTES FOR PLANT STOCK QUALITY REQUIREMENTS AND ADDITIONAL PLANTING REQUIREMENTS.

IF UNSTABLE ROOTBALLS ARE ENCOUNTERED CALL OREGON CITY URBAN FORESTRY FOR PLANTING DIRECTION.

PLANTING DEPTH: TOP OF STRUCTURAL (FLARED) ROOT SYSTEM TO BE 1" ABOVE FINISH GRADE. WATER TO DRAIN AWAY FROM TOP OF STRUCTURAL (FLARED) ROOT SYSTEM.

3" COMPACTED BENTONITE OR DIAMETER MINIMUM IN PLANTER BEDS FOR GROUND WATERING BASIN. MULCH TO COVER SOIL BERM AND FILL WATER BASIN - NO LANDSCAPE FABRIC.

SCAVERY PLANTING AREA TO A MIN. 12" DEPTH.

SCAVERY SIZES OF PLANTING PIT TO BE 3X THE DIAMETER OF THE ROOTBALL AND THE SAME DEPTH AS THE ROOTBALL AFTER EXCESS SOIL IS REMOVED AND THE TOP OF THE ROOT CROWN IS IDENTIFIED.

UNDISTURBED ROOT BALL

6'-0" MIN.

6"

2'-0"

3 TIMES ROOT BALL (R.T.S.)

12 GAUGE WIRE MESH RUBBER HOSE OR AN APPROVED EQUAL. PLACE ABOVE FIRST SET OF LINES AND 6" APART.

3" DEEP WATERING BASIN - FILL WITH BARK MULCH AS SPECIFIED ON PLANS.

BARK MULCH DEPTH TO BE 4"-6". KEEP MULCH 4" AWAY FROM TRUNK.

NATURAL GRADE/FINISHED GRADE.

SCAVERY PLANTING AREA TO A MIN. 8"-10" DEPTH. CLEANED AND WASHED ROCK MULCH SHALL BE PLACED OVER COMMERCIAL GRADE PERMEABLE LANDSCAPE FABRIC.

CLEANED AND WASHED ROCK MULCH SHALL BE PLACED OVER COMMERCIAL GRADE PERMEABLE LANDSCAPE FABRIC.

INSTALL NEW WATER SOLUBLE BAGS/TABLETS STARTER PLANT FERTILIZER. PLACE 6" OUTSIDE & 2"-3" BELOW TOP OF ROOTBALL. SEE GENERAL LANDSCAPE NOTES FOR QUANTITY, BATCH/L MATERIAL. TO BE SCREENED, FREE OF ROCKS LARGER THAN 1" AND NOSTRIFIED BEFORE INSTALLATION. (BATCH/L MIX - 3/4 PART VANTIC SOIL AND 1/4 PART APPROVED TOP SOIL MIX OR SOIL CONDITIONER).

CONTRACTOR TO SCAVERY BOTTOM OF PLANTING PIT TO 6" DEPTH OR AS REQUIRED NECESSARY TO BREAK THROUGH ANY RESTRICTIVE LAYER AND PROVIDE SUFFICIENT DRAINAGE (SEE SPECIFICATIONS FOR PERCOLATION TEST ON PLANTING HOLES).

6" TALL EVERGREEN TREE OR LARGER

(2) STAKES TO BE 8" X 2" X 2" PRESSURE TREATED WOOD STAKES DRIVEN 2" INTO UNDISTURBED NATIVE SOIL OUTSIDE OF ROOTBALL (PLACE PERPENDICULAR TO PREVAILING WIND). CUT STAKES TO UNIFORM HEIGHT. STAKE HEIGHT & PLACEMENT SHALL NOT CREATE INTERFERENCE WITH BRANCHES.

SCALE: NTS

NO.		REVISION	DATE	Standard Landscape Detail	
				EVERGREEN TREE	
				TYPICAL PLANTING DETAIL IN LANDSCAPING AREA	

File Name: [C:\landscape details\12903.dwg]	
Landscape Detail Number: L-XX	
Date: 2/2007	Page: 5

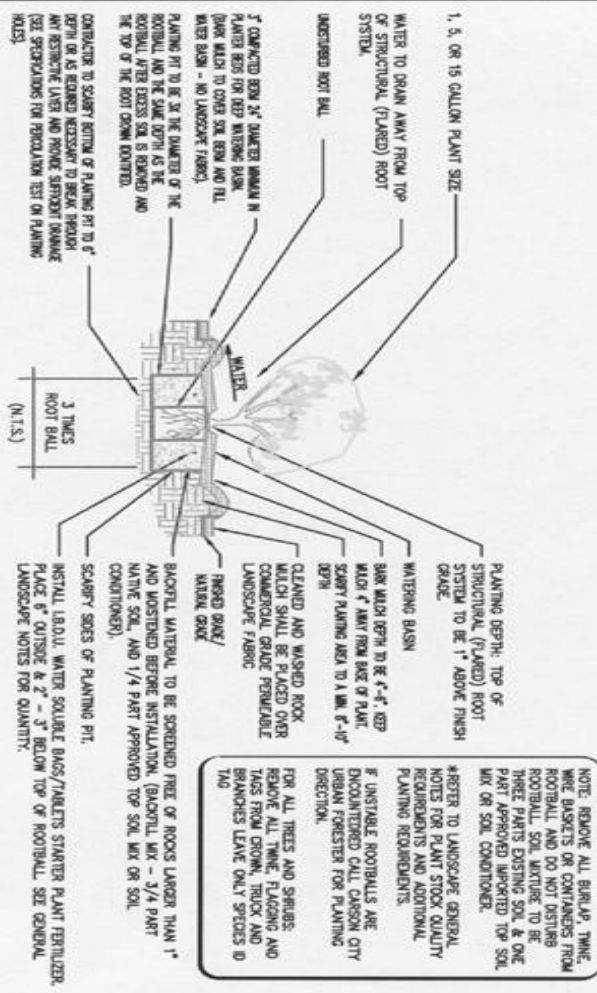

NOTE: REMOVE ALL BURLAP, TWINE, WIRE BASKETS OR CONTAINERS FROM ROOTBALL AND DO NOT DISTURB ROOTBALL SOIL MIXTURE TO BE THREE PARTS EXISTING SOIL & ONE PART APPROVED IMPORTED TOP SOIL MIX OR SOIL CONDITIONER.

*REFER TO LANDSCAPE GENERAL NOTES FOR PLANT STOCK QUALITY REQUIREMENTS AND ADDITIONAL PLANTING REQUIREMENTS.

IF UNSTABLE ROOTBALLS ARE ENCOUNTERED CALL CALSON CITY URBAN FORESTER FOR PLANTING DIRECTION.

FOR ALL TREES AND SHRUBS: REMOVE ALL TWINE, FLAGGING AND TAGS FROM CROWN, TRUNK AND BRANCHES LEAVE ONLY SPECIES ID TAG

SCALE: NTS			Standard Landscape Detail		File Name: <small>[H:\landscape detail\2903.dwg]</small>	
NO.	REVISION	DATE	DECIDUOUS/EVERGREEN SHRUB			Landscape Detail Number: L-XX
			TYPICAL PLANTING DETAIL IN LANDSCAPE AREAS			Date: 2/2007
						Page: 7

IRRIGATION LEGEND**

2/2007

SYMBOL	BRAND	MODEL NUMBER	P.S.I.	G.P.M.	RADIUS	COMMENTS
	RAINBIRD	1804-8Q-FLT	30	.39	8'	4" POP-UP SPRAY HEAD
	RAINBIRD	1804-8H-FLT	30	.79	8'	4" POP-UP SPRAY HEAD
	RAINBIRD	1804-10Q-LA	30	.39	10'	4" POP-UP SPRAY HEAD
	RAINBIRD	1804-10H-LA	30	.79	10'	4" POP-UP SPRAY HEAD
	RAINBIRD	1804-10F-LA	30	.57	10'	4" POP-UP SPRAY HEAD
	WILKINS	BACKFLOW PREVENTER				BACKFLOW PREVENTER (INSTALL IN STRONG BOX INSULATED BACKFLOW COVER)
	STRONG BOX	SBBC-45 ALU				45" LONG, 29.5" HIGH, 16" WIDE, (ALUMINUM INSULATED COVER, LOW PROFILE).
	WATOURS	ISOLATION VALVE/GATE VALVE				1 1/2" OR 2" GATE VALVE (MATCH TO MAINLINE SIZE)
	MUELLER	CURB AND STOP WASTE VALVE				1" VALVE (MATCH TO MAINLINE SIZE)
	WILKINS	500 SERIES				2" PRESSURE REDUCING VALVE
	RAINBIRD	150-PEB				1 1/2" ELECTRIC PLASTIC VALVE (SPRAY SYSTEM)
	RAINBIRD	44RC				1" QUICK COUPLING VALVE
	---	PVC MAINLINE - SIZE INDICATED ON DRAWINGS				SCHEDULE 40 PIPE
	---	1" - 2" DIAM. PVC LATERAL LINES - SIZE INDICATED ON DRAWINGS				SCHEDULE 40 PIPE
	---	EXISTING PVC IRR. SLEEVES (NEW SLEEVES INDICATED ON DRAWINGS)				
	---	VALVE NUMBER GALLONS				
DRIP IRRIGATION SYSTEM **						
	RAINBIRD	XZ-100				CONTROL ZONE KIT W/ 1" DV ELECTRIC PLASTIC VALVE (DRIP SYSTEM) (USE CARSON INDUSTRIES, INC. VALVE BOX OR AN APPROVED EQUAL - SIZE 13 1/2" x 23 1/2")
	PEPCO	3/4" DRIP TUBING				
	PEPCO	FLUSHING END CAP				
	RAINBIRD	XB-10 OR XB-10-6 EMITTERS				SINGLE OR MULTI OUTLET PRESSURE COMPENSATING - INSTALL DRIP TO ALL PLANTS
** IDENTIFIED BRANDS ARE FOR ILLUSTRATION PURPOSES ONLY. THE LANDSCAPE ARCHITECT OR DESIGN PROFESSIONAL IS RESPONSIBLE FOR SPECIFYING THE PROPER EQUIPMENT FOR THE IRRIGATION SYSTEM.						

SCALE: NTS

NO.	REVISION	DATE	Standard Irrigation Detail	File Name:
			TYPICAL IRRIGATION LEGEND	[H:\landscape detail\IRR-LEGEND.dwg]
				Landscaping Detail Number: L-XX
				Date: 2/2007 Page: 8

NOTES:

1. STAKE DISTRIBUTION TUBING IN PLACE AT SURFACE OF EACH EMITTER.
2. ALL PLANTS LOCATED ON SLOPES SHALL HAVE EMITTERS PLACED UP HILL FROM PLANT.
3. DO NOT WRAP DISTRIBUTION TUBING AROUND PLANT STEM OR TREE TRUNK.
4. DO NOT PLACE EMITTERS AGAINST PLANT STEM OR TREE TRUNK.
5. PLACE EMITTERS AROUND PLANT FOR EQUAL DISTRIBUTION OF WATER.
6. CONTRACTOR IS RESPONSIBLE TO ESTABLISH WATERING TIMES AND DURATIONS.
7. EMITTER (GPH) WATER RATE MAY BE ALTERED DUE TO SOIL TYPE AND SOIL DRAINAGE CHARACTERISTICS.

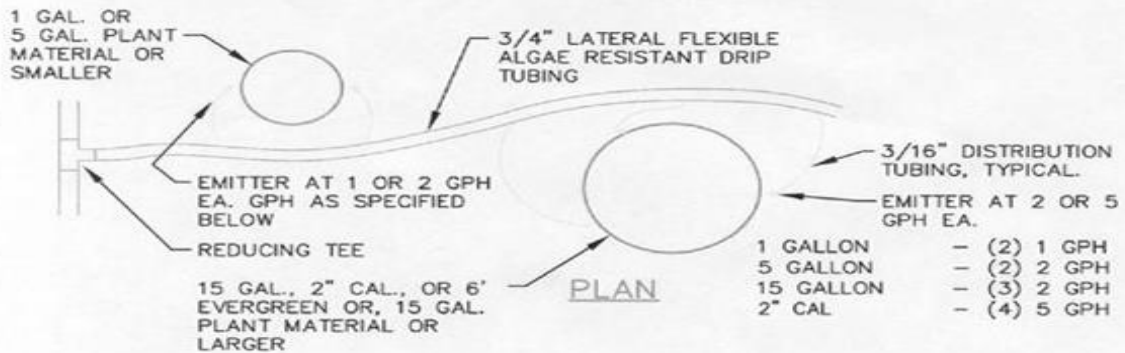

SCALE: NTS

NO.			REVISION			DATE			Standard Irrigation Detail			File Name:	
TYPICAL DRIP EMITTER DETAIL									[P:\landscape detail\DRIP.dwg]			Landscape Detail Number:	
												L-XX	
									Date: 2/2007		Page: 9		

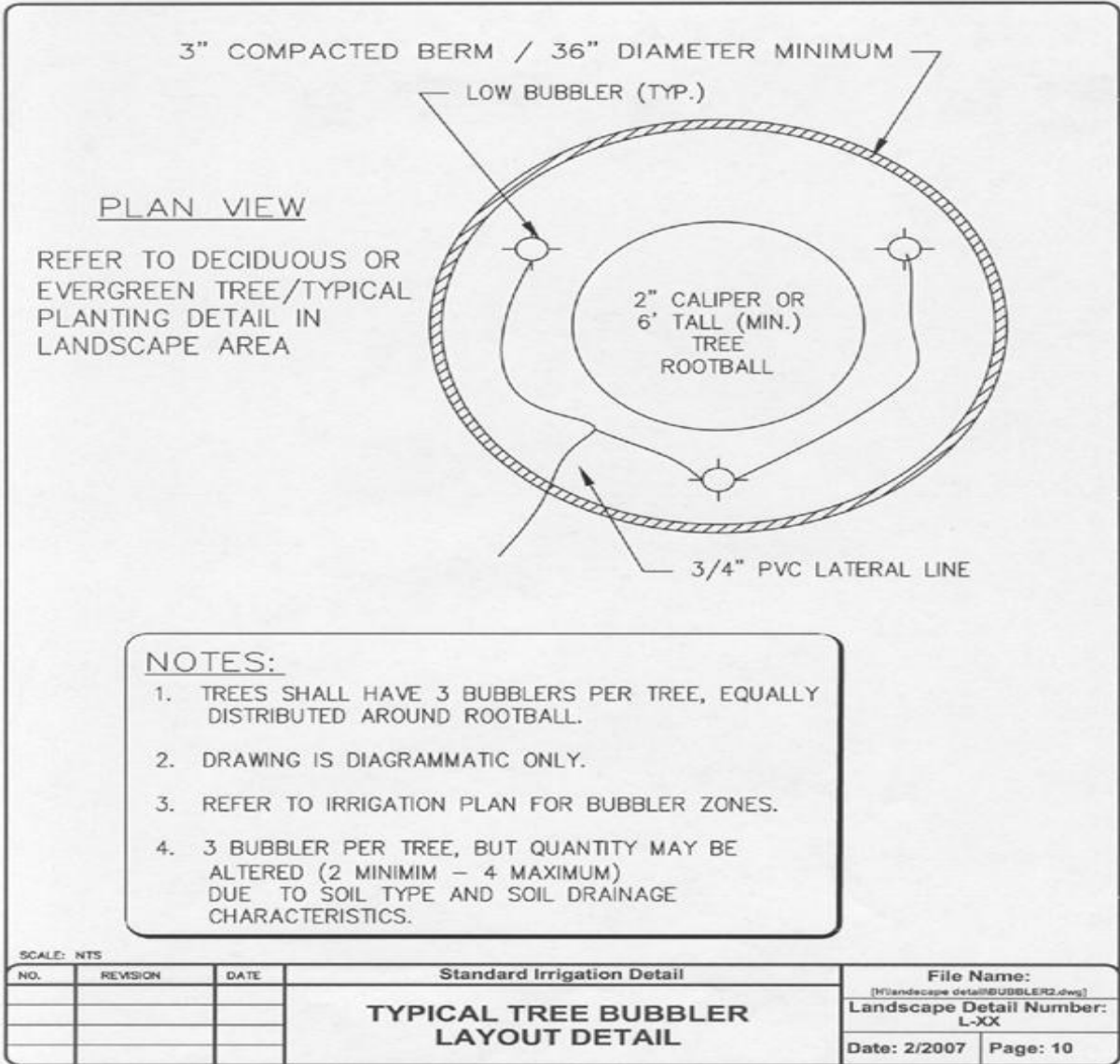

NOTE:
 FENCE SHALL BE LOCATED A
 MINIMUM OF 5' AWAY FROM
 THE TREE'S DRIP LINE

TREE PROTECTION ZONE
 THIS FENCE SHALL NOT BE REMOVED
 UNTIL PROJECT HAS BEEN COMPLETED

**PROTECTIVE
 TREE FENCING**
 This fence shall not be
 removed and is subject
 to a penalty according to
 Carson City Municipal
 Code Section 3.4.2

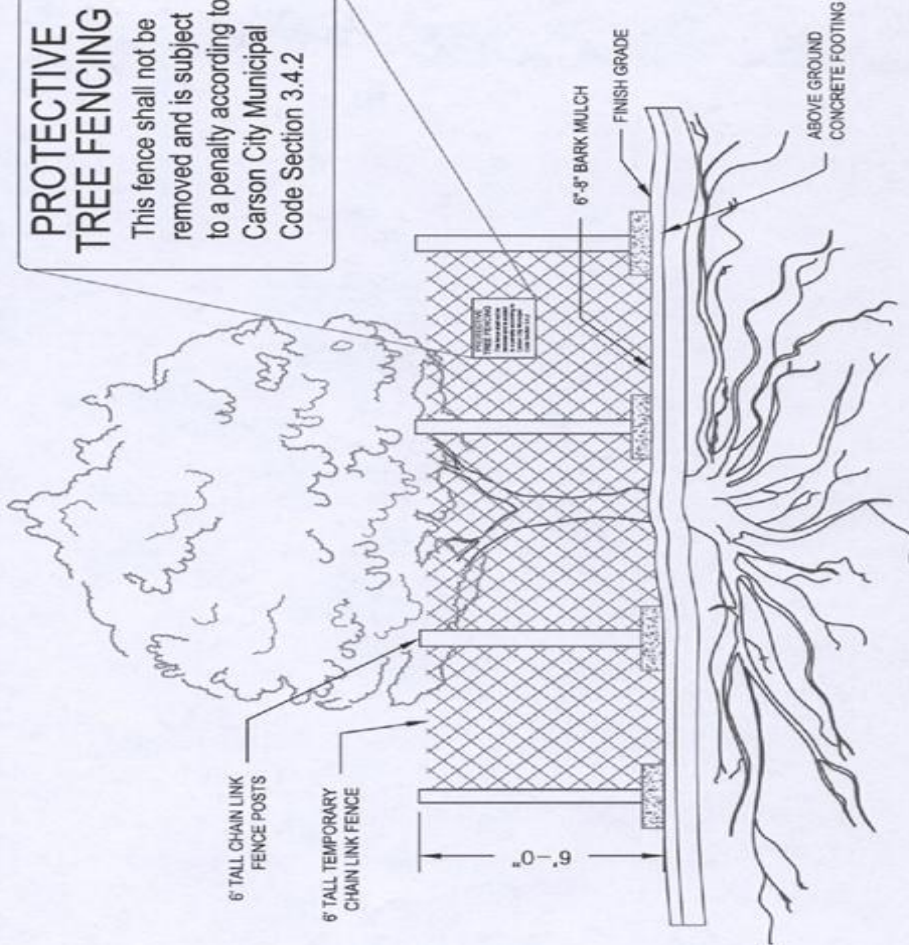

SCALE: NTS

NO.	REVISION	DATE

Standard Site Amenity Detail

**TYPICAL TREE PROTECTION
 FENCE DETAIL**

File Name:

[P:\landscape detail\slTPZ.dwg]

Landscape Detail Number:
 L-XX

Date: 2/2007

Page: 11

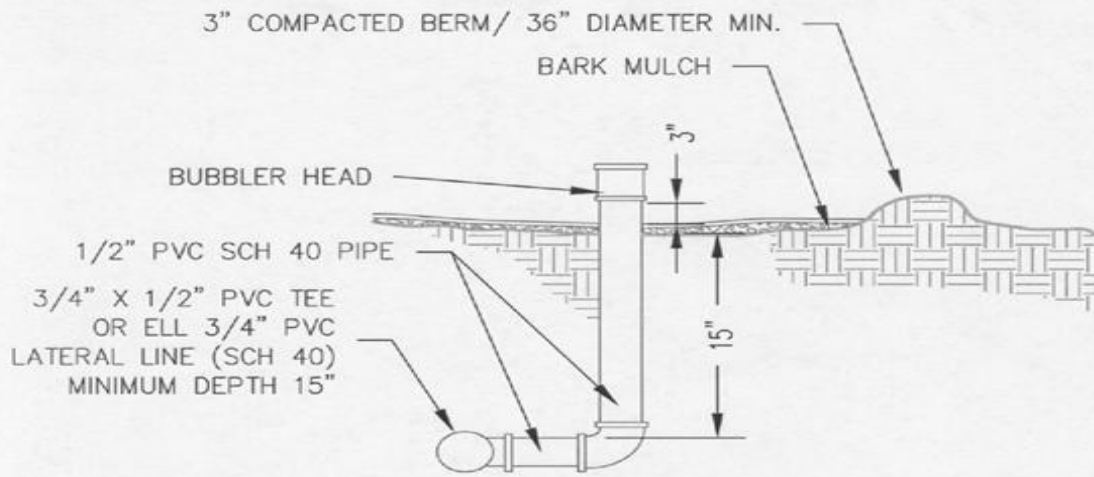

NOTES

1. TREES SHALL HAVE 3 BUBBLERS PER TREE, EQUALLY DISTRIBUTED AROUND ROOTBALL.
2. IN LANDSCAPE PLANTING AREA BUBBLER HEADS NEED TO BE 3" ABOVE BARK MULCH
3. 3 BUBBLER PER TREE QUANTITY MAY BE ALTERED (2 MIN. / 4 MAX.) DUE TO SOIL TYPE AND SOIL DRAINAGE CHARACTERISTICS.

SCALE: NTS

NO.			REVISION			DATE			Standard Irrigation Detail			File Name:	
									TYPICAL TREE BUBBLER DETAIL			[H:\landscape details\BUBBLER1.dwg]	
												Landscape Detail Number: L-XX	
											Date: 2/2007	Page: 12	

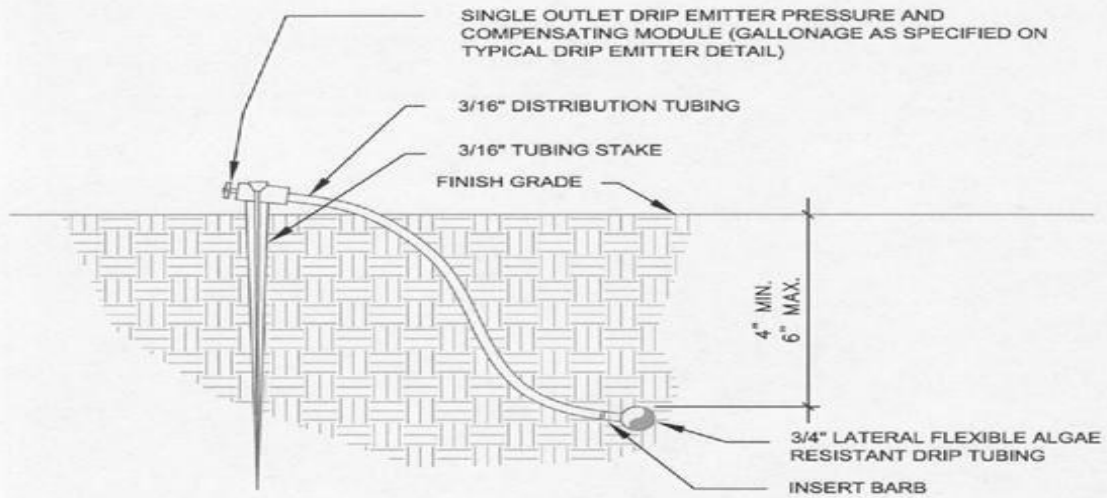

NOTES:

1. INSERT BARB DIRECTLY INTO FLEXIBLE DRIP TUBING FOR INSTALLATION OF DISTRIBUTION TUBING.
2. PLACE EMITTERS ON OUTER EDGE OF ROOT BALL AND SOIL OUTSIDE OF ROOT BALL SO PLANT MATERIAL WILL RECEIVE WATER. DO NOT PLACE EMITTER AT BASE OF TRUNK OR STEM PLANTS.

SCALE: NTS

Standard Irrigation Detail			File Name:	
NO.	REVISION	DATE	[H:\landscape details\dripem.dwg]	
			Landscape Detail Number: L-XX	
			Date: 2/2007	Page: 13

TYPICAL DRIP EMITTER STAKING DETAIL

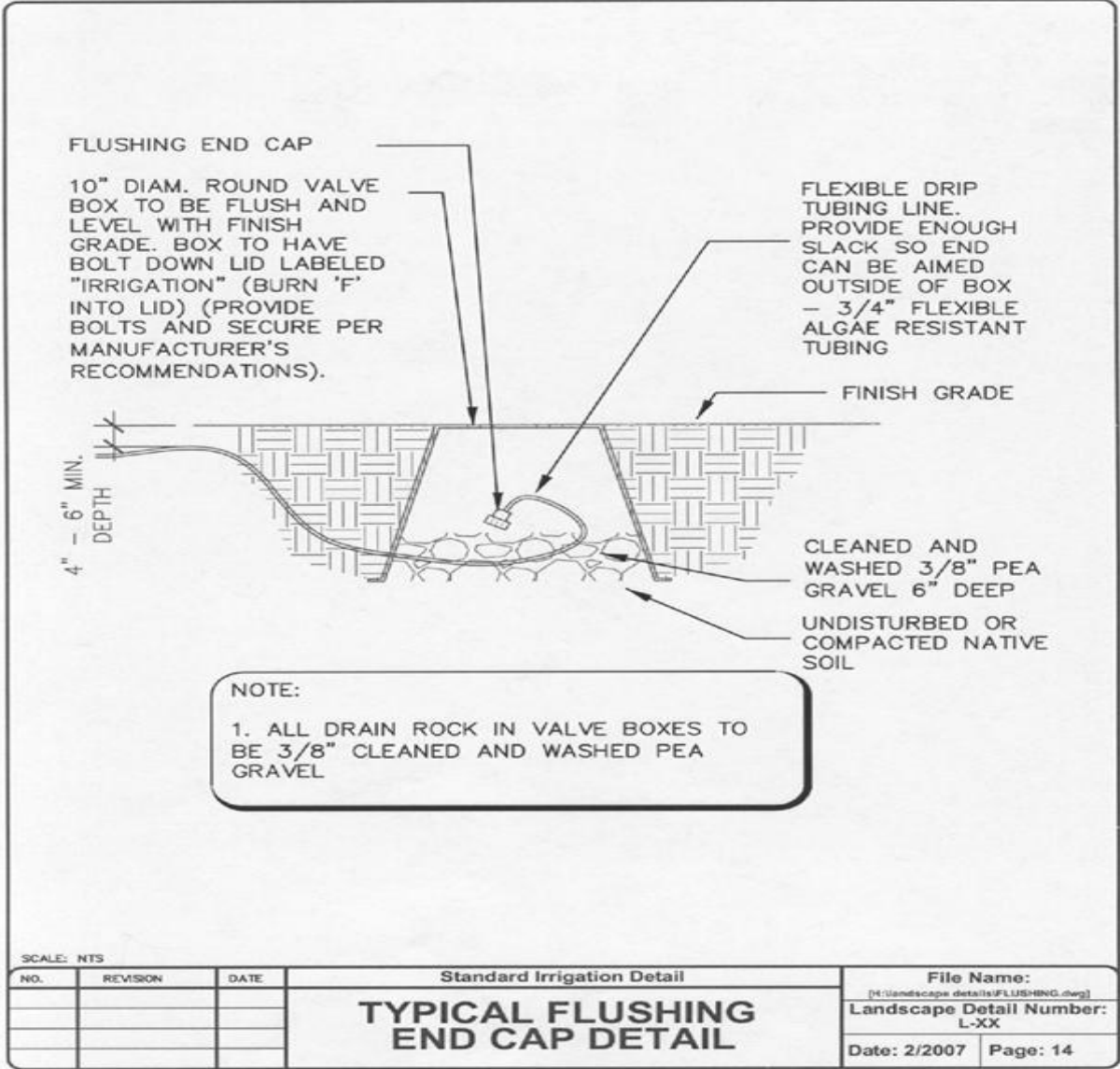

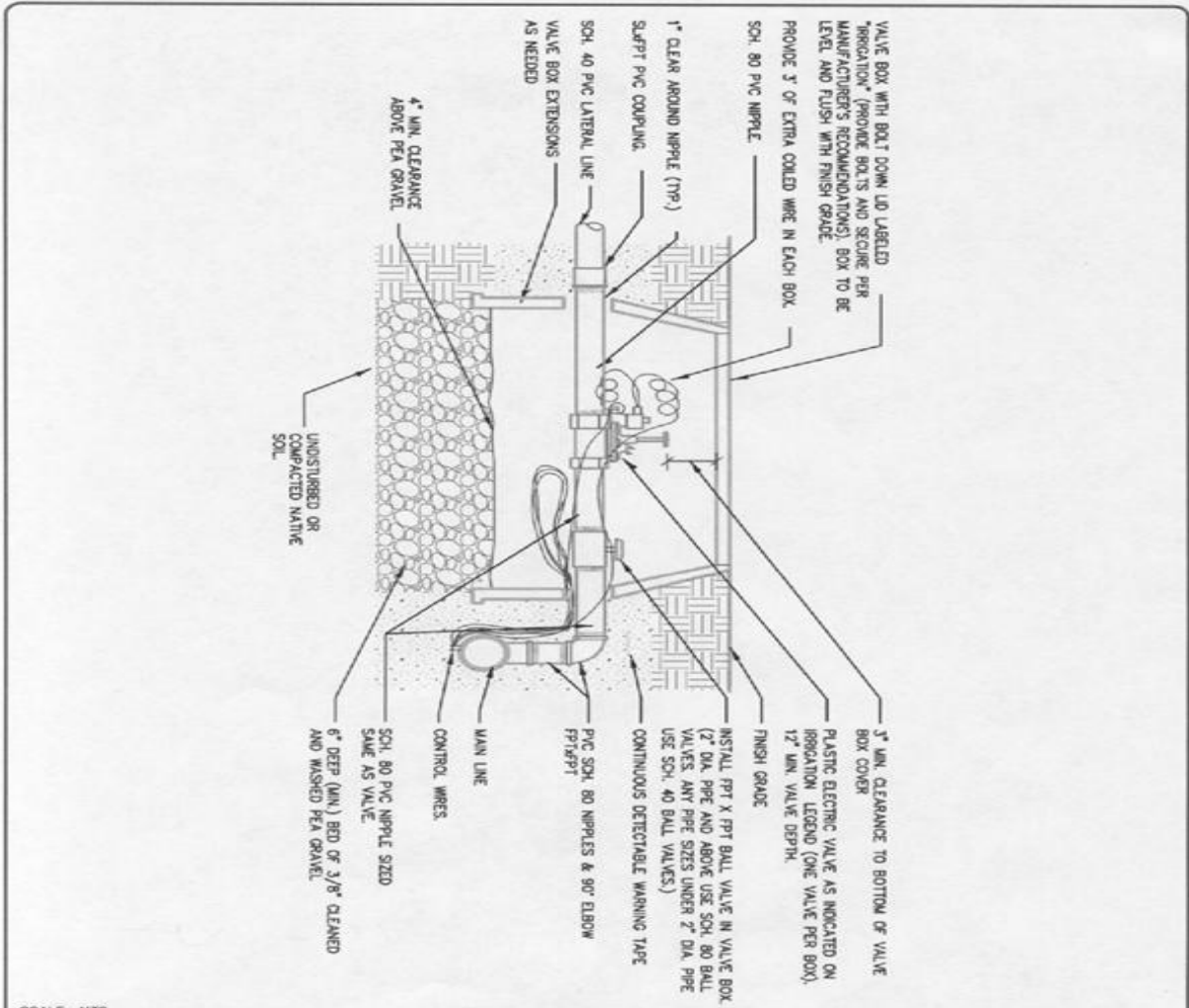

SCALE: NTS

Standard Irrigation Detail			File Name:
NO.	REVISION	DATE	[H:\landscape details\spray-valve.dwg]
TYPICAL SPRAY VALVE DETAIL			Landscape Detail Number: L-XX
			Date: 2/2007 Page: 16

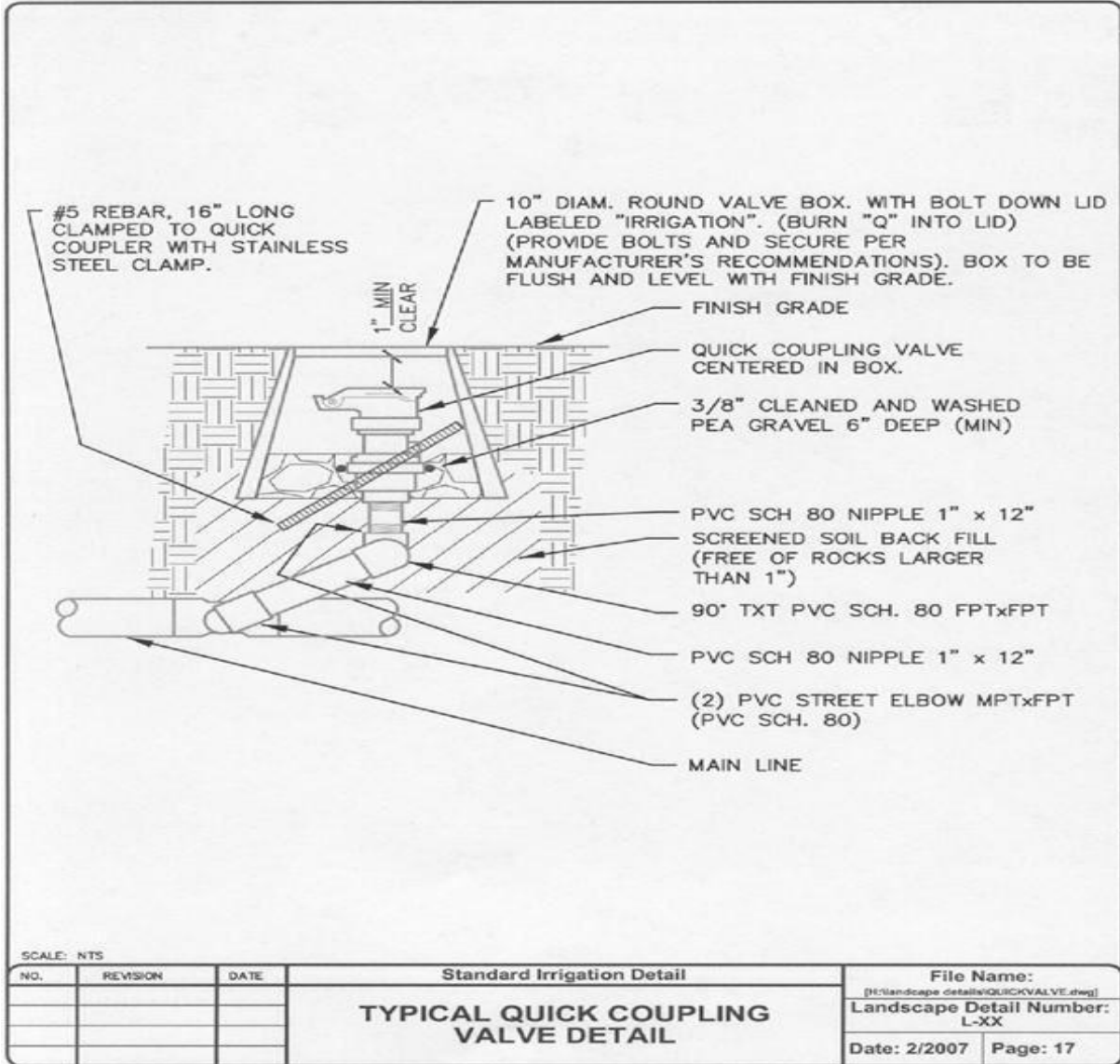

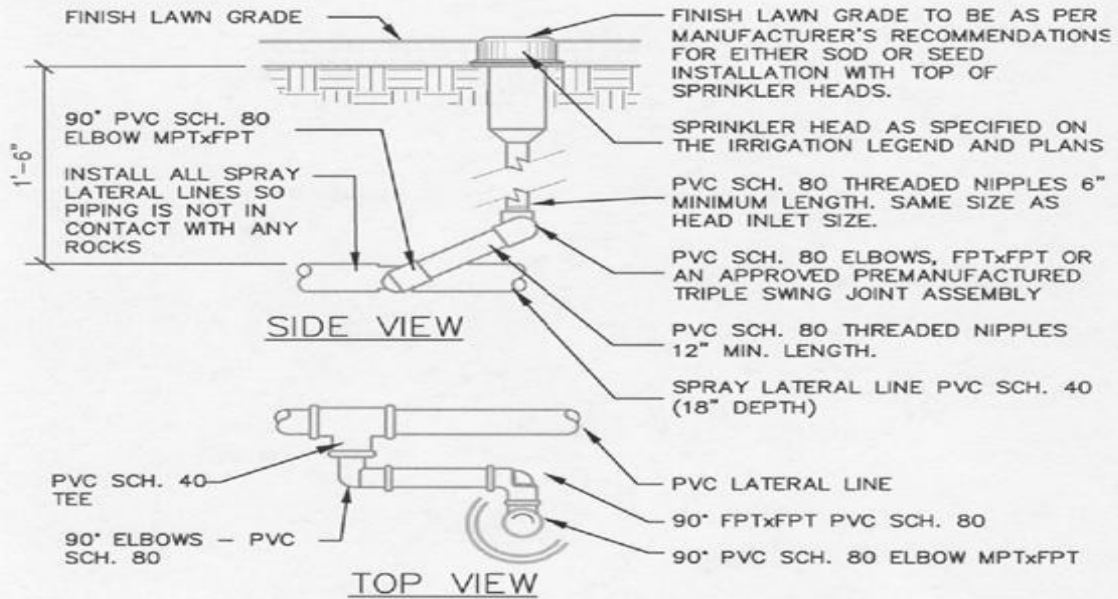

NOTE:

1. MARLEX STREET ELBOWS MAY BE SUBSTITUTED FOR 90° PVC SCH. 80 ELBOWS.

SCALE: NTS

Standard Irrigation Detail			File Name:	
NO.	REVISION	DATE	[H:\Landscape details\ROTOR.dwg]	
			Landscape Detail Number: L-XX	
			Date: 2/2007	Page: 18
TYPICAL ROTOR/POP-UP HEAD DETAIL				

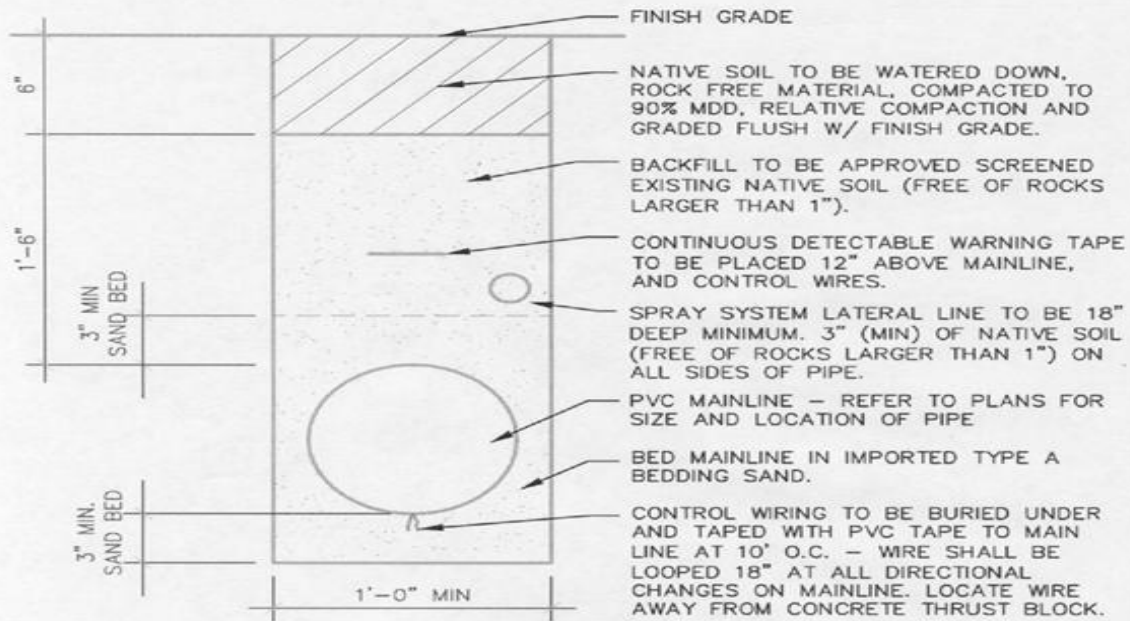

SCALE: NTS

Standard Irrigation Detail			File Name:	
NO.	REVISION	DATE	[D:\Landscape details\TRENCH1.dwg]	
			Landscape Detail Number: L-XX	
			Date: 2/2007	Page: 19

**TYPICAL IRRIGATION TRENCH
WALL SECTION DETAIL**

NOTES:

1. THERE MUST ALWAYS BE A MINIMUM OF 10" OF TOP SOIL OVER THE GRAVEL BACKFILL.
2. ROCK LANDSCAPING WALL OVER 4' IN HEIGHT REQUIRES ENGINEERING CALCULATIONS TO BE SUBMITTED TO THE CARSON CITY BUILDING DEPARTMENT.

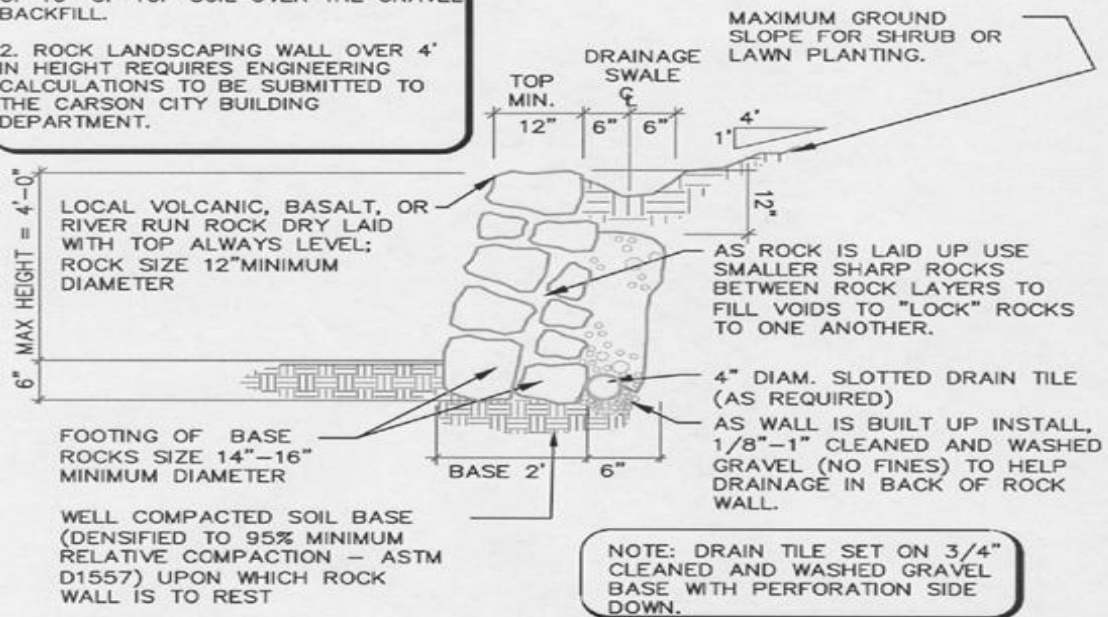

SCALE: NTS

Standard Site Amenity Detail			File Name:
NO.	REVISION	DATE	[H:\landscaping details\L2002.dwg]
TYPICAL DRY-LAID ROCK LANDSCAPING WALL DETAIL			Landscape Detail Number: L-XX
			Date: 2/2007

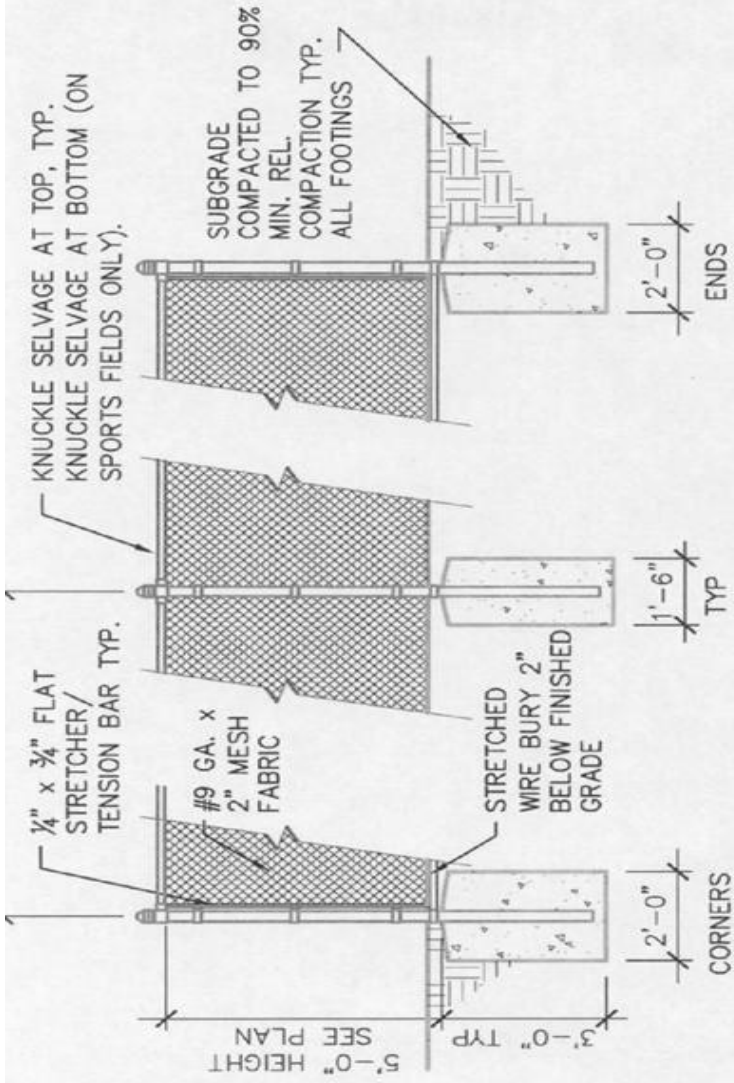

NOTES:

1. TOP RAIL SHALL BE 1 5/8" O.D. SCH 40 STEEL.
2. FENCES 8' OR HIGHER SHALL HAVE 1 5/8" O.D. MID RAIL.
3. CORNER AND END POSTS SHALL BE 3" O.D. AT 6' AND 4' HIGH FENCE.
4. INTERMEDIATE POSTS SHALL BE 2 1/2" O.D. AT 6' AND 4' HIGH FENCE, 3" O.D. AT 8' OR HIGHER FENCE.
5. FENCING FABRIC, POSTS, RAILS AND HARDWARE SHALL BE GALVANIZED.

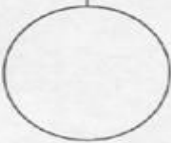

CHAIN LINK FENCE

CHAINLINKFENCE

1/4" = 1'-0"

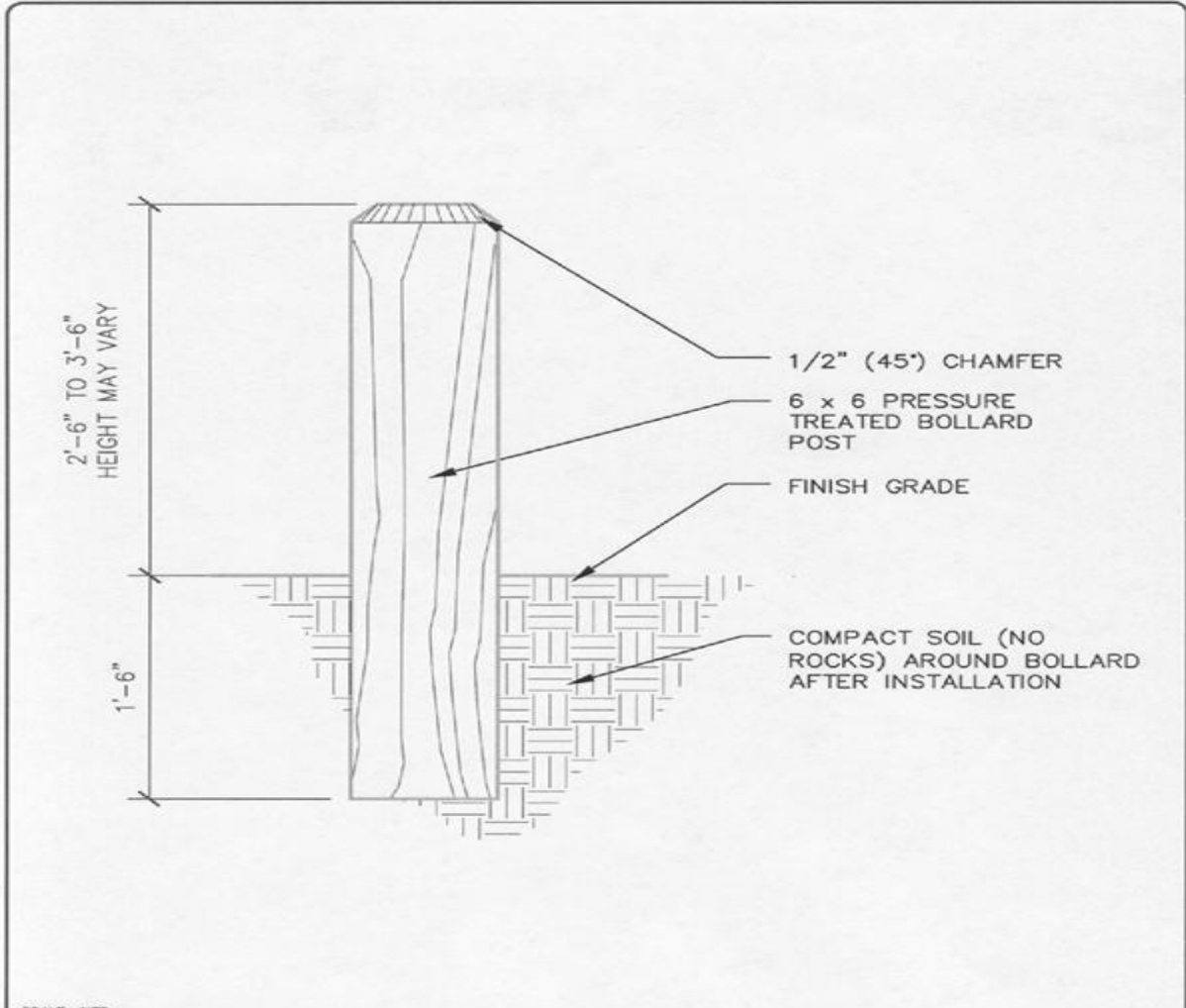

SCALE: NTS

Standard Landscape Site Amenity Detail			File Name:	
NO.	REVISION	DATE	[H:\landscape detail\SL2001.dwg]	
TYPICAL WOOD BOLLARD DETAIL			Landscape Detail Number:	
			L-XX	
			Date: 2/2007	Page: 22

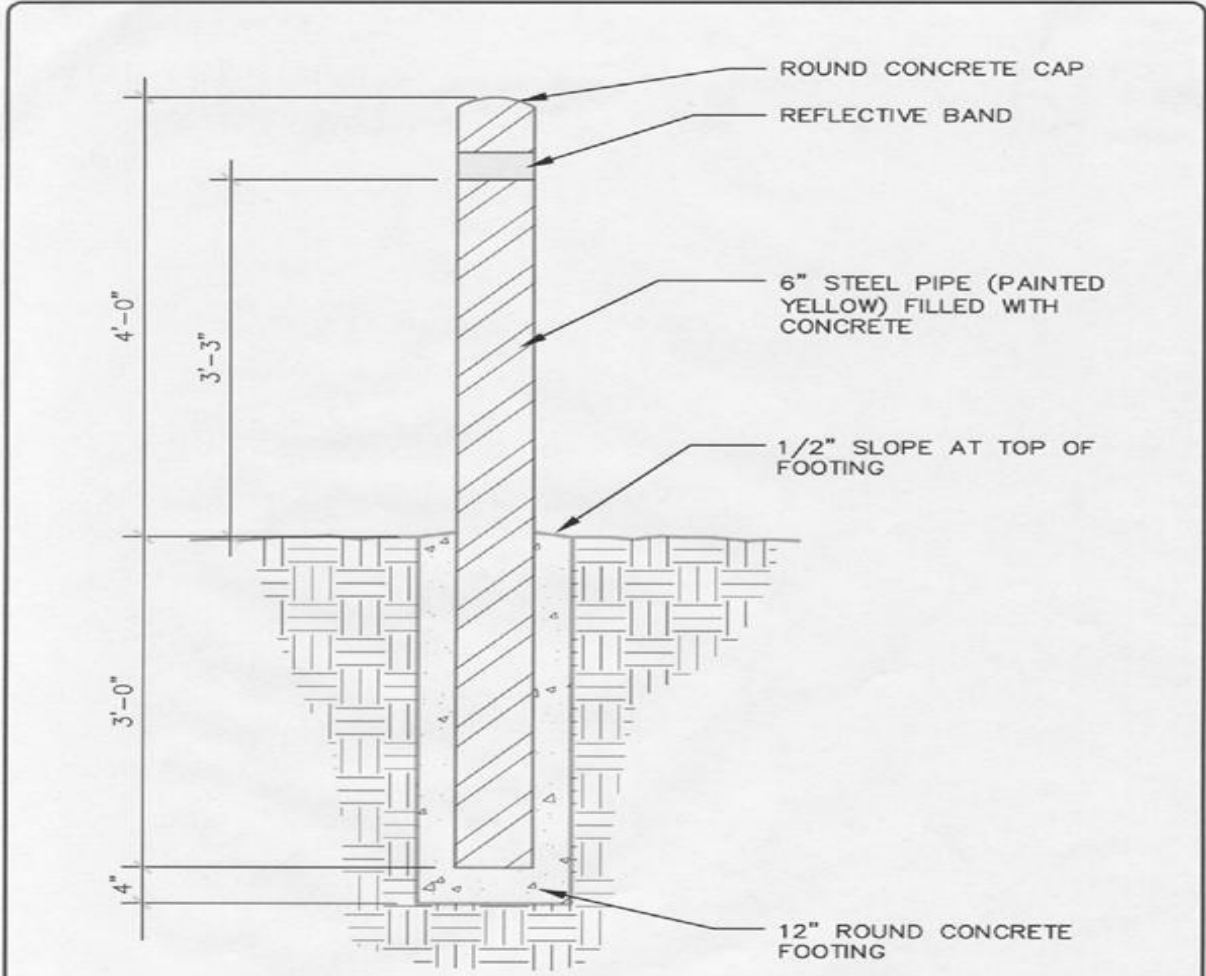

SCALE: NTS

Standard Landscape Detail			File Name:
NO.	REVISION	DATE	[H:\landscape details\pipebollard.dwg]
			Landscape Detail Number: L-XX
			Date: 5/2006 Page: 23

PIPE BOLLARD DETAIL

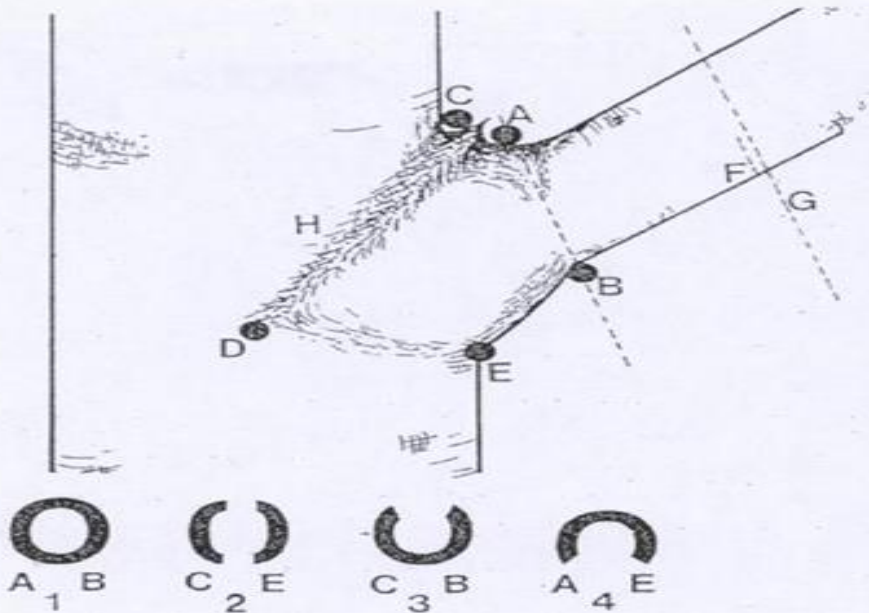

NATURAL TARGET PRUNING

Locate the branch bark ridge (H) and the branch collar (E to B).
 Stub cut the branch (up F, down G).
 Locate points A and B where the branch meets the branch collar.
 Cut from A to B, or from B to A with care.
 If position of B is uncertain, draw a line in your mind from A to E.
 Angle EAD is approximately the same as angle EAB.
 Point D is the beginning of the branch bark ridge (H).
 A proper cut will result in woundwood pattern 1.
 Improper cuts will result in patterns 2, 3, and 4.
 Do not leave stubs.
 Do not make flush cuts.
 Do not paint the wounds.



COOPERATIVE EXTENSION
Bringing the University to You

Wendy Hanson
 Horticulture Assistant
 Master Gardener Program Coordinator

3305 Mill St. • P.O. Box 11130 • Reno, NV 89520
 Reno (775) 794-4648 FAX (775) 794-4881
 Carson City (775) 887-2252 FAX (775) 887-2065
 Gardener-ID# (775) 782-8948 FAX (775) 782-8948
 E-mail: hansonw@cnr.edu
 Web site: www.cnre.unr.edu

Natural Target Pruning

Hardwoods

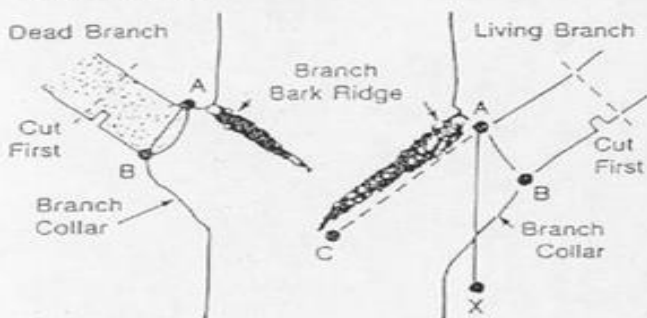

Do Not

- Cut behind the branch bark ridge
- Leave stubs
- Cut branch collar
- Paint cuts—except for cosmetics
- Leave flat top when topping

Topping

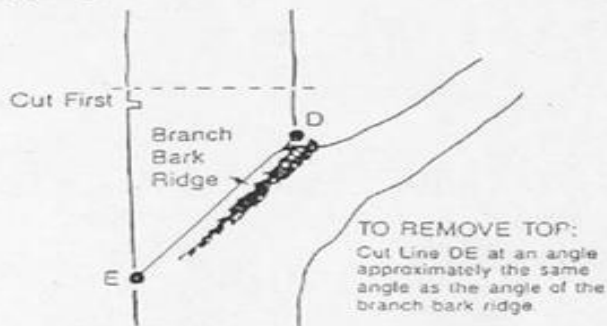

Page 2

Natural Pruning Steps

1. Locate the branch bark ridge
2. Find TARGET A—outside of branch bark ridge
3. Find TARGET B—swelling where branch meets branch collar
4. If B is hard to find—drop a line at AX, Angle XAC=to angle XAB
5. Stub branch to be pruned
6. Make cut at line AB

Conifers

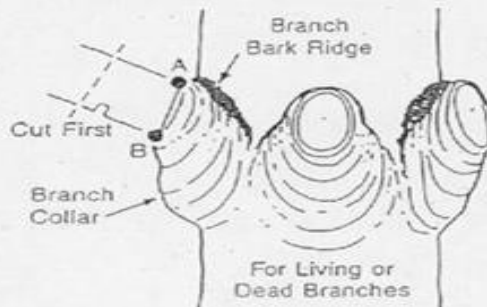

BEST TIME TO PRUNE

Late dormant season or EARLY spring before leaves form

FOR MORE INFORMATION WRITE:

Northeastern Forest
Experiment Station
P.O. Box 640
Durham NH 03824

or
your local State Forestry or
USDA Forest Service Office

TREE RETENTION/PROTECTION

- 1) Where trees are to be retained on a site, protection barriers must be installed as specified in 3.4.2.
- 2) Any required excavation in or around the protection barrier to accommodate underground services, footing, etc. should be indicated on the plan and completed by hand.
- 3) Trees inside the protection zone should be cared for throughout the construction process, i.e., they must be watered sufficiently if a portion of the tree's root system has been disturbed by excavation.
- 4) Root and branch pruning, where necessary, must be done in accordance with 3.4.2.

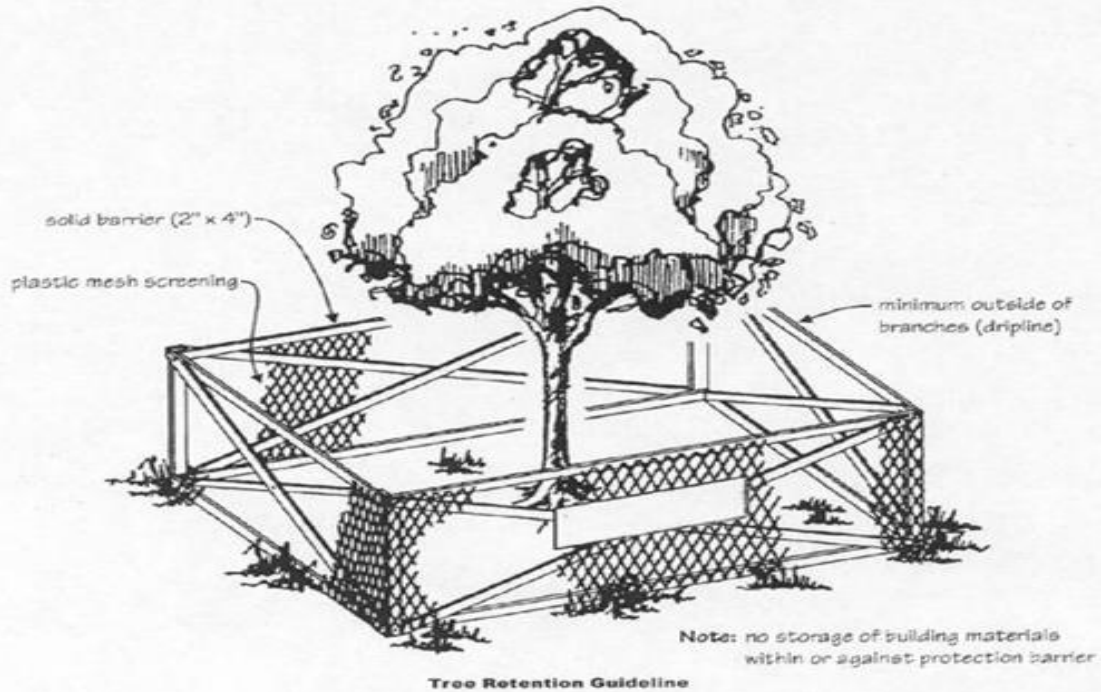

Root Pruning

Root pruning is the practice of removing a portion of a tree's root system. As a first alternative, adding soil and reseeding is recommended to prevent the removal of key structural roots. However, root pruning sometimes becomes necessary in order to accommodate landscape features such as walks, retaining walls, drains or utilities. Root pruning may also be necessary when existing roots begin to interfere with the routine maintenance of surrounding lawns and shrub beds. For example, it would be better to remove a surface root which is continually wounded by a lawn mower blade rather than to increase potential for disease through open wounds in the root. Other reasons for root pruning may include transplanting and undesirable growth patterns.

The circumstances necessitating root pruning vary, but the objective of tree root pruning is always to ensure the health, stability and longevity of the tree. Therefore, major root pruning should only be done by, or in consultation with, an Arborist or other qualified landscape professional.

The following general guidelines for root pruning are provided for your convenience:

- A tree should be root pruned only if the problem can be solved by removing less than 33 percent of the tree's roots, with no more than 25 percent from one side.
- For trees 30 cm in diameter and less, roots should not be removed within 1.2 m of the outer edge of the tree base. Trees with diameters over 30 cm should be allowed an additional 30 cm for every extra 7.5 cm of trunk diameter measured at a point 1.4 m above ground. For example, a tree with a 37.5 cm diameter trunk measured 1.4 m above the ground would require a minimum 1.55 m allowance around it.
- Cut roots cleanly after excavation with clean, sharp tools, to promote callous formation and wound closure. Wounds may be dressed with a tree rooting hormone compound that is available at garden centres.
- Backfill the excavation as soon as possible and water the soil around roots to avoid leaving air pockets.
- Mix soil improvements (e.g. peat moss) with fill soil to promote new root growth, especially if the existing soil is of poor quality. The soil quality can be easily determined by using a basic soil testing kit which is readily available at most nursery supply stores. Do not add fertilizers until improved tree growth is noticed, generally after 6 to 8 weeks during a growing season. Soil testing will better determine soil deficiencies and additional amendment requirements.
- Surface roots which interfere with other elements in the landscape can be removed under the supervision of an Arborist or other qualified landscape professional. Each tree has a different root system and requires individual analysis and treatment.



PLAN VIEW:
Maximum 25% on one side or no more than 33% of total root system.

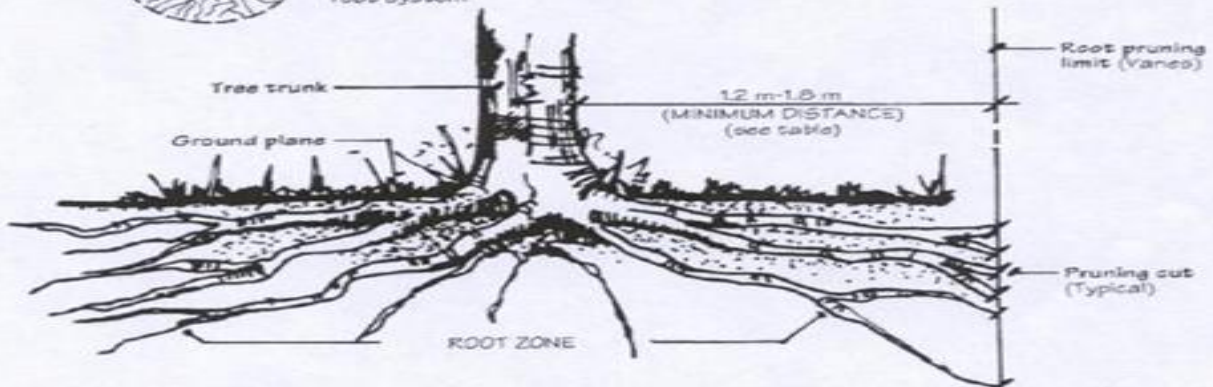

Root Pruning Guidelines

Excavation Adjacent to Retained Trees

In cases where proposed building excavation will affect existing trees to be retained, special attention should be given to proper root pruning and care for the remaining root system. Alternatively, a post and beam structure for the building may be considered to retain the rooting space (see diagram, Alternative 2). It is important to note that most roots are located in the top 60 cm of soil, with the major roots for water and nutrients absorption in the top 20 to 30 cm.

- In order to minimize root damage, soil erosion and tree disturbance, a temporary root curtain² should be wrapped around the root zone to retain and protect the exposed area. The root curtain should consist of heavy wire mesh or similar material lined with burlap (to retain moisture) and supported by posts. Backfill should be used as required to ensure that none of the roots are left exposed. Only hand excavation should be used in the root zone area.
- It is critical that the root zone system (or roots of the tree) be kept moist by watering as required throughout the construction process.
- Once the foundation is ready to be backfilled, the root curtain can be carefully removed. It is of utmost importance that the area surrounding the tree be kept free of building materials, as well as pedestrian and vehicular traffic, to avoid soil compaction.
- Tunnelling rather than trenching should be considered when installing underground utilities and drainage lines to minimize damage to existing trees. This technique entails boring a hole under or through the root system with minimum disturbance. To ensure that the work is undertaken in the appropriate manner, a certified Arborist or similarly qualified landscape professional should be consulted if the applicant decides to use this technique.

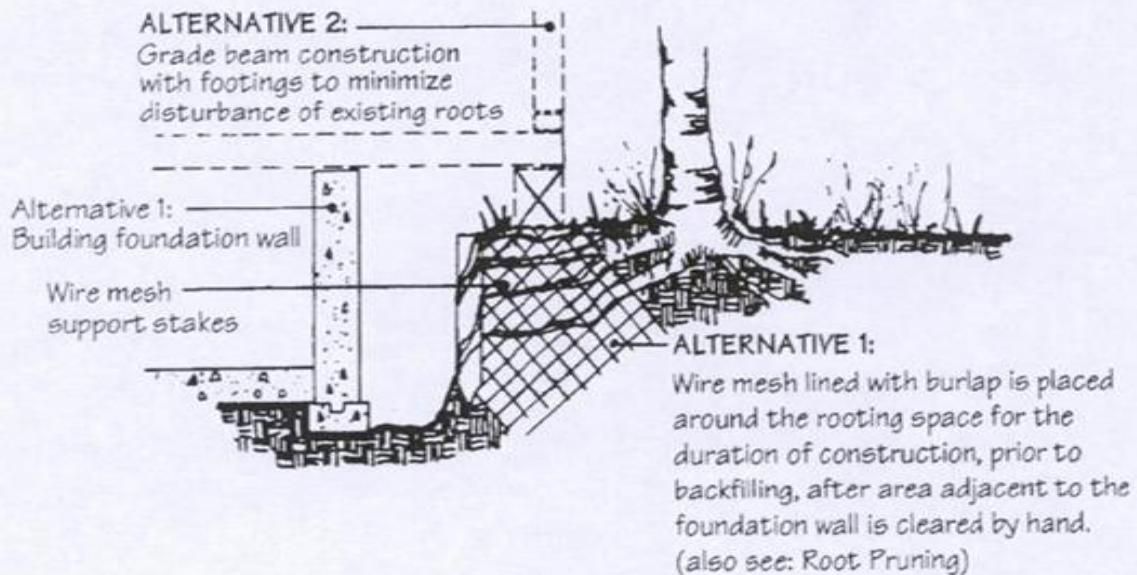

Owner Maintenance Agreement

All landscaping, irrigation and screening shall be maintained at all times to conform to the regulations of Development Standards Division 3 Landscaping. Landscaping and related equipment including, but not limited to, trees, shrubs, plants, screens, walkways, benches, fountains and irrigation systems shall be maintained by the present or subsequent owner of the property. The owner of the property is responsible for maintaining or assuring the ongoing maintenance of installed landscaping so that the landscaping continues to thrive. Each owner shall be required at all times to keep all landscaping materials in good health, repair and maintenance.

The City may require the immediate replacement of any and all dead or damaged plant materials at any time. If any portion of the landscaping material or irrigation equipment is dead, dying, damaged, destroyed or otherwise affected, the owner of the development project shall replace or repair the damaged or affected material within thirty days following notification from the Director. If the season of the year makes this repair or replacement impractical within the thirty-day period, the person responsible for the landscaping shall submit a letter of request to the Director asking for a delay to replace materials and shall submit a time frame for the accomplishment of this work. If the repair or replacement is not accomplished in a timely fashion the Director may initiate proceedings to revoke the special use permit or business license for the subject use.

Signature of Owner

Date



Carson City Tree List for Commercial Projects

USDA Zone: 5 (Plant Material)

Sunset Zone: 3

Species and Varieties Appropriate for Proposed Site That Are Not on This List Are Subject to Approval, Not Including Accent Trees

Deciduous

Small Tree - Less than 30 feet (single stem)

- | | |
|---|--------------------------------------|
| ACER ginnala 'Flame' | Amur Maple |
| * AMELANCHIER species varieties | Serviceberry |
| CARPINUS caroliniana | American Hornbeam |
| CATALPA bignonioides 'Nana' | Umbrella Catalpa |
| * CRATAEGUS species thornless varieties | Hawthorn |
| FRAXINUS pennsylvanica 'Johnson' | Leprechaun Green Ash |
| KOELREUTERIA paniculata | Goldenrain Tree |
| * MALUS species varieties | Flowering Crabapple (<1" size fruit) |
| * PRUNUS maackii | Amur Chokecherry |
| * PRUNUS padus | European Bird Cherry |
| * PRUNUS virginiana 'Canada Red' | Canada Red Chokecherry |
| SORBUS americana 'Dwarfcrone' | Red Cascade Mountain Ash |

Medium Tree - 30 feet to less than 50 feet tall

- | | |
|---|-----------------------|
| ACER fremanii 'Jeffersred' | Autumn Blaze Maple |
| * ACER negundo 'Sensation' | Sensation Box Elder |
| ACER nigrum 'Greencolumn' | Greencolumn Maple |
| * ACER platanoides varieties | Norway Maple |
| ACER pseudoplatanus varieties | Sycamore Maple |
| * ACER rubrum varieties | Red Maple |
| ACER saccharum 'Green Mountain' | Sugar Maple |
| CARPINUS betulus varieties | European Hornbeam |
| CATALPA speciosa | Northern Catalpa |
| CELTIS occidentalis | Common Hackberry |
| CELTIS reticulata | Western Hackberry |
| * FRAXINUS americana varieties | White Ash |
| FRAXINUS excelsior | European Ash |
| FRAXINUS ornus | Flowering Ash |
| * FRAXINUS pennsylvanica varieties | Green Ash |
| FRAXINUS quadrangulata | Blue Ash |
| * GLEDITSIA triacanthos inermis varieties | Thornless Honeylocust |
| GYMNOCLADUS dioicus | Kentucky Coffeetree |
| * PYRUS calleryana varieties | Callery Pear |

* - Carson City Historic District Preferred Tree

- QUERCUS lobata
- QUERCUS robur 'Fastigiata'
- * ROBINIA x ambigua 'Idaho'
- * SORBUS aucuparia varieties
- * TILIA cordata varieties
- TILIA tomentosa varieties

Large Tree - 50 feet or greater

- * PLATANUS occidentalis
- * PLATANUS x acerifolia 'Bloodgood'
- * QUERCUS coccinea
- QUERCUS douglasii
- QUERCUS macrocarpa
- QUERCUS robur 'Fastigiata'
- * QUERCUS rubra
- TILIA americana varieties
- ZELKOVA serrata

- Valley Oak
- Skyrocket English Oak
- Idaho Locust
- Mountain Ash
- Littleleaf Linden
- Silver Linden

- American Sycamore
- London Planetree
- Scarlet Oak
- Blue Oak
- Bur Oak
- Columnar English Oak
- Red Oak
- American Linden
- Sawleaf Zelkova

Evergreen

Small Tree - Less than 30 feet (single stem)

- * PINUS mugo
- PINUS thumbergiana

- Swiss Mountain Pine
- Japanese Black Pine

Medium Tree - 30 feet to less than 50 feet tall

- * JUNIPERUS species varieties
- * PICEA pungens varieties
- PINUS aristata
- PINUS edulis
- PINUS monophylla
- PINUS nigra
- PINUS sylvestris

- Juniper tree
- Spruce
- Bristlecone Pine
- Two-Needle Pinyon Pine
- Single-Leaf Pinyon Pine
- Austrian Pine
- Scotch Pine

Large Tree - 50 feet or greater

- * ABIES concolor
- * CALOCEDRUS decurrens
- CEDRUS atlantica
- * PICEA pungens
- PINUS contorta latifolia
- * PINUS jeffreyi
- * PINUS ponderosa
- SEQUOIA DENDRON giganteum

- White Fir
- Incense Cedar
- Atlas Cedar
- Colorado Spruce
- Lodgepole Pine
- Jeffrey Pine
- Ponderosa Pine
- Giant Sequoia

* - Carson City Historic District Preferred Tree

Carson City Riparian Area List

Scientific Name

Common Name

Tree

ACER negundo	Boxelder
ALNUS incana spp. tenuifolia	Thinleaf Alder
ALNUS rubra	Red Alder
ALNUS sinuata	Sitka Alder
BETULA occidentalis	Water (Black) Birch
CRATAEGUS douglasii	Black/Douglas Hawthorn
POPULOUS fremontii	Cottonwood
POPULUS angustifolia	Narrowleaf Cottonwood
POPULUS balsamifera spp. Trichocarpa	Black Cottonwood
POPULUS tremuloides	Quaking Aspen
PRUNUS virginiana 'Canada Red'	Canada Red Chokecherry
SALIX alba	White Willow
SALIX amygdaloides	Peachleaf Willow
SALIX nigra	Black Willow
SALIX prolixa	Mackenzie Willow
SAMBUCUS coerulea	Blue Elderberry

Carson City Riparian Area List

Scientific Name

Common Name

Shrub

CORNUS sericea	Redosier Dogwood
ELAEGNUS commutata	Silverberry
PENTAPHYLLOIDES floribunda	Shrubby Cinquefoil
PHILADELPHUS lewisii	(Mockorange) Syringa
RHUS tribobata	Skunkbush Sumac
RIBES aureum	Golden Current
RIBES cereum	Wax (Squaw) Current
ROSA woodsii	Wood's Rose
SALIX bebbiana	Bebb Willow
SALIX boothii	Booth Willow
SALIX drummondiana	Drummond Willow
SALIX exigua ssp. Exigua	Coyote Willow
SALIX exigua ssp. Melanopsis	Coyote Willow
SALIX geyeriana	Geyer Willow
SALIX lemmonii	Lemmon Willow
SALIX lutea	Yellow Willow
SALIX lutia spp. Lasiandra	Pacific (Whiplash) Willow
SALIX planifolia var. planifolia	Planeleaf Willow
SALIX scouleriana	Scouler Willow
SALIX sitchensis	Sitka Willow
SAMBUCUS racemosa spp. Pubens	Red Elderberry
SHEPHERDIA argentea	Silver Buffaloberry
SYMPHORICARPOS albus	Common Snowberry

1

SECTION XXXX:

That Title 18 Appendix (CARSON CITY DEVELOPMENT STANDARDS), Division 3 (LANDSCAPING) is hereby amended by adding thereto a new Section 3.20 (Design standard illustrations) (**bold, underlined** text is added, [~~stricken~~] text is deleted) as follows:

3.20 Carson City Standard Details for Public Works Construction.

All design standards that are necessary to carry out the provisions of this Division, including, without limitation, illustrations, diagrams and landscaping, irrigation and

**planting notes and legends, must be maintained by the City and amended from time to time as necessary. A copy of the standards may be obtained from the Carson City Publics Works Department or from the following Internet website:
<https://www.carson.org/government/departments-a-f/community-development/development-engineering-division/details-for-public-works-construction>.**

SECTION XXXX:

That Title 18 Appendix (CARSON CITY DEVELOPMENT STANDARDS), Division 3 (LANDSCAPING) is hereby amended by adding thereto a new Section 3.25 (Owner maintenance agreements) (**bold, underlined** text is added, [~~stricken~~] text is deleted) as follows:

3.25 Owner maintenance agreements.

An owner maintenance agreement that is entered into between the City and any other person for landscaping, irrigation or screening in accordance with the provisions of this Division must include the following substantially similar language:

Owner Maintenance Agreement

All landscaping, irrigation and screening shall be maintained at all times to conform to the regulations of Development Standards Division 3 Landscaping. Landscaping and related equipment including, but not limited to, trees, shrubs, plants, screens, walkways, benches, fountains and irrigation systems shall be maintained by the present or subsequent owner of the property. The owner of the property is responsible for maintaining or assuring the ongoing maintenance of installed landscaping so that the landscaping continues to thrive. Each owner shall be required at all times to keep all landscaping materials in good health, repair and maintenance.

The City may require the immediate replacement of any and all dead or damaged plant materials at any time. If any portion of the landscaping material or irrigation equipment is dead, dying, damaged, destroyed or otherwise affected, the owner of the development project shall replace or repair the damaged or affected material within thirty days following notification from the Director. If the season of the year makes this repair or replacement impractical within the thirty-day period, the person responsible for the landscaping shall submit a letter of request to the Director asking for a delay to replace materials and shall submit a time frame for the accomplishment of this work. If the repair or replacement is not accomplished in a timely fashion the Director may initiate proceedings to revoke the special use permit or business license for the subject use.

Signature of Owner

Date

SECTION XXXX:

That Title 18 Appendix (CARSON CITY DEVELOPMENT STANDARDS), Division 4 (SIGNS), Section 4.1 (Findings) is hereby amended (**bold, underlined** text is added, ~~stricken~~ text is deleted) as follows:

4.1 Findings.

The [~~Carson City board of supervisors (board)~~] **Board of Supervisors hereby** finds that the establishment of regulations and minimum standards for the erection and maintenance of outdoor signs and billboards within the [~~city~~] **City** is necessary [~~for the purpose of promoting~~] **to promote** the [~~public~~] health, safety and general [~~welfare,~~] **welfare of the public,** and **further declares that** the establishment of such regulations and minimum standards [~~is~~] **must be** in

accordance with the provisions of and purposes [of Chapter 278, Nevada Revised Statutes (NRS).] **set forth in chapter 278 of NRS.**

SECTION XXXX:

That Title 18 Appendix (CARSON CITY DEVELOPMENT STANDARDS), Division 4 (SIGNS), Section 4.2 (Purpose) is hereby amended (**bold, underlined** text is added, [~~stricken~~] text is deleted) as follows:

4.2 Purpose.

The purpose of this [~~division~~] **Division** is to provide minimum standards to safeguard life, health, property and public welfare in keeping with the unique character of Carson City by establishing equal enforcement, regulation and control where applicable by the size, number, height, design, quality of materials, construction, location, electrification and maintenance of all signs and sign structures not located within a building, except temporary signs attached to or affixed upon windows, and to accomplish the following results:

- a. To protect and enhance the character of residential and commercial neighborhoods, open views and vistas, and property values by prohibiting signs that are obtrusive and incompatible with the immediate surroundings;
 - b. To protect the economic health of commercial centers and property values by encouraging signs that effectively communicate the availability of goods and services to consumers;
 - c. To provide a reasonable and comprehensive system of sign management addressing size, location, design, and illumination for integration into the zoning ordinance;
 - d. To encourage signs that are varied in design, well constructed, and pleasing in appearance;
 - e. To attract and direct persons to various activities and enterprises in order to provide for the public convenience;
 - f. To prohibit the indiscriminate use of other outdoor advertising.
- 4.2.1 Constitutionality and legality. If any provision of this [~~division~~] **Division** is declared by a court of competent jurisdiction to be illegal or unconstitutional, it shall in no way affect the remainder of this [~~division~~] **Division** or any section thereof, it being intended that the remainder shall remain in full force and effect.
- 4.2.2 Conflict with state law. If this [~~division~~] **Division** or any of the provisions herein are or become in conflict with existing state law, the same shall be null and void as to that particular provision or section until otherwise amended or such conflict is reconciled.

SECTION XXXX:

That Title 18 Appendix (CARSON CITY DEVELOPMENT STANDARDS), Division 4 (SIGNS), Section 4.3 (Definitions) is hereby amended (**bold, underlined** text is added, [~~stricken~~] text is deleted) as follows:

4.3 Definitions.

[Definitions of terms not listed below may be found in the Sign Code as currently adopted by Carson City and/or Section 18.03 (Definitions) of Title 18 of the Carson City Municipal Code (CCMC) as adopted. Where differences exist between definition of terms in this division and those of the Sign Code as currently adopted by Carson City and/or Section 18.03 (Definitions) of Title 18 of the CCMC, the more restrictive definition will be applied. Unless a different meaning is clearly indicated, the terms listed in this division will have the following meanings when used in this title.] **As used in this Division, unless the context otherwise requires, the words and terms defined in this section have the meanings ascribed to them.**

"Administrative Code" is the latest edition as currently adopted by and in effect in Carson City.

"Area identification sign" means a permanent sign used to identify a neighborhood, subdivision, shopping district or industrial district.

"Area of sign" is any portion of a sign display surface area on which the sign copy appears.

"Balloon" is an inflatable device that is less than eighteen (18) inches in height and width.

"Banner" means a temporary flexible sign or similar device.

"Billboards" mean outdoor advertising signs containing a message, commercial or otherwise, which is unrelated to the merchandise for sale or services performed by the person or business on whose property the sign is located, posted for a fee by the owner of the sign framework.

"Building Code" [~~is the latest~~] **or "International Building Code" means the most current edition [as currently adopted by and in effect in Carson City.] of the International Building Code as adopted by the City pursuant to chapter 15.05 of title 15 of CCMC.**

"Building facade" means face of a building to the lower edge of the roof.

"Building inspector" is the Carson City Building Official or their duly authorized designee.

"Changeable promotional flag" is a flag that may or may not contain a commercial message, excluding official flags.

"Changeable promotional sign" is a sign consisting of a permanent exterior framework structure surrounding a temporary changeable copy sign intended for the advertisement of special events, promotions and sales.

"Community directional sign" is any permanent sign erected and maintained by the city, county, state or federal government within the public right-of-way for traffic direction to any school, hospital, historical site, or church, or to any public service, property or facility.

"Community directory sign" is a permanent sign located within the public right-of-way along the major arterial entrances to the city that give information about local religious institutions and civic organizations.

"Compliance officer" is the Carson City community development director (director) or designee.

"Corporate flag" is a flag that contains the corporate logo of the business located on the parcel on which the flag is flown.

"Directional sign" is an on-premise sign giving directions, instructions or facility information, including but not limited to parking, exit and entrance signs. A directional sign may contain a logo, but no advertising copy, provided that the logo may not comprise more than twenty (20) percent of the total sign area.

"Display surface" means the surface of the sign upon, against or through which the message is displayed or illustrated on the sign.

"Dissolve" is a mode of message transition on an electronic message display accomplished by varying the light intensity or pattern, where the first message gradually appears to dissipate and lose legibility simultaneously with the gradual appearance and legibility of the subsequent message.

"Double-faced sign" is any sign designed to be viewed from two (2) directions and on which two (2) faces of the sign are either parallel or the angle between them is thirty (30) degrees or less.

"Downtown business directional sign" is any sign erected in the right-of-way within the downtown area that may contain advertisement for businesses located within the downtown area and is intended to assist pedestrians in locating downtown businesses.

"Electronic message display" is any sign capable of displaying words, symbols, figures or images that can be electronically or mechanically changed by remote or automatic means.

"Erect" means to build, construct, attach, hang, place, suspend or affix and also includes the painting of wall signs.

"Fade" is a mode of message transition on an electronic message display accomplished by varying the light intensity, where the first message gradually reduces intensity to the point of not being legible and the subsequent message gradually increases intensity to the point of legibility.

"Feather flag" means a vertically oriented banner of flexible material attached to a single pole allowing the fabric to hang loose at one (1) or two (2) sides of the banner.

"Flag, official" includes the flags of the United States of America, the state of Nevada, the consolidated municipality of Carson City, flags of the U.S. military including P.O.W./M.I.A. flags, and any flag approved by the board or any foreign nation having diplomatic relations with the United States which are flown in accordance with protocol established by the Congress of the United States.

"Flashing sign" is an illuminated sign in which the artificial light is not maintained in a stationary or constant intensity.

"Frame" is a complete, static display screen on an electronic message display.

"Freestanding sign" means a sign which is permanently supported by any structure which is not an integral part of any building located upon the premises. This definition does not include portable signs.

"Freeway intersection" is a point at the intersection of the centerlines of the freeway and a street at which there is a freeway off-ramp.

"Freeway-oriented sign" is any freestanding on-premise sign that exceeds the maximum permitted sign height or sign area for a commercial use or shopping center and is designed to be visible from at least one direction of the Carson City Freeway.

"Frontage of building" means the lineal length of any portion of a building facing any adjacent public street or parking area. Where the allowable sign area is a function of building or business frontage, no more than two (2) frontages may be counted in calculating the allowable area for any building occupant.

"Hanging sign" is a sign attached to and located below any eave, roof, canopy or awning.

"Height, sign" means the height of a sign as determined by measurement from adjacent, finished grade to the highest point of the sign's structure.

"Indirectly lighted or Shadow-lighted sign" means any illuminated sign constructed so that the immediate source of the illumination is not visible when the sign is lighted.

"Inflatable device" is an inflated object filled, whether mechanically or otherwise, with air or other gas for the purpose of attracting attention, excluding "balloons" as defined in this division.

The terms "listed and listing" refer to equipment or materials included in a list published by an approved testing laboratory, inspection agency or other organization concerned with product evaluation that maintains periodic inspection of current productions of listed equipment or materials. The published list shall state that the material or equipment complies with approved nationally recognized codes, standards or tests and has been tested or evaluated and found suitable for use in a specified manner.

A "logo" is a graphic representation or symbol of a company name, trademark, abbreviation, etc., used for ready recognition.

"Marquee" is a sign other than a wall sign which is attached to and projects either perpendicular to or at any angle from a building.

"Monument sign" means a detached sign with a solid base equal to or greater than the length of the sign copy and connected solidly to or arising from the ground.

"Non-conforming sign" is a sign which may have been validly installed under laws or ordinances in effect prior to the effective date of this division, but which is now in conflict with the provisions of this division.

Official Flag. (See "Flag, official.")

"Off-premise sign" is a sign which advertises or informs about goods, products, services or uses not directly concerning the use on the property upon which the sign is located.

"Parapet" is that portion of a wall of a building which extends higher than the roof of the same building.

"Parapet sign" is a sign which is affixed to the parapet of a building and parallel thereto.

"Parcel" means any real property shown on the latest adopted tax roll as a unit.

"Pennant" is any lightweight plastic, fabric or other material not exceeding eighteen (18) inches in length, whether or not containing a message of any kind, suspended from a rope, pole, wire or string, usually in a series or as a single flag, designed to move in the wind.

"Permanent sign" is any sign which from nature and effect of its proposed composition, construction, message to be carried, or its proposed placement would make it reasonable to determine that it was intended for continuous display.

"Person" means any person, firm, partnership, associations, co-partnership, company or organization of any kind.

"Political sign" is a sign designed for the purpose of advertising support of or opposition to a candidate or proposition.

"Portable sign" is a sign that is designed to be movable and is not structurally attached to the ground, a building, a structure or any other sign, and includes signs carried by a person/pedestrian.

"Projecting sign" is a sign other than a wall sign which is attached to and projects either perpendicular to or at any angle from a building.

"Reader board sign" is a sign or a part of a sign on which the messages are readily changeable.

"Real-property sign" is a sign placed upon real property to advertise that the property upon which the sign is placed, or any piece or parcel thereof, or any interests therein, is or will be for sale, exchange, lease or rent.

"Roof sign" means a sign erected upon a roof, the ridge of a roof or a parapet of a building or structure.

"Roof-mounted sign" means a sign erected upon a roof of a building which extends higher than the highest portion of the roof or parapet where the sign is located.

"Shopping center" means a group of five (5) or more commercial establishments planned and developed as a unit on a single parcel or commonly managed parcels of land that utilize an undivided or unsegregated parking area.

"Sign" means anything displayed with the intent to attract attention, advertise, promote and or direct any person when the sign is placed so that it is visible from any public right-of-way, common parking area, or surrounding properties.

"Sign area" is any portion of a sign display surface area on which the sign copy appears.

"Sign Code" is the latest edition as currently adopted by and in effect in Carson City.

"Street" includes any public street, alley, way, place or thoroughfare. The sidelines of the right-of-way constitute the sidelines of a street.

"Structure" means a structure which is built or constructed, any edifice or building of any kind or any piece of work artificially built up or parts joined together in some definite manner.

"Temporary sign" refers to any sign meeting the definition of a "sign" which is not permanently installed.

"Transition" is a visual effect used on an electronic message display to change one message to another.

"Value" is the total estimated cost of the sign including labor materials.

"Wall sign" means any sign attached, painted or erected against a wall of a building or structure with the exposed face of the sign in a plane parallel to the plane of the wall.

"Window sign" is a sign maintained in or painted upon a window, including all signs located inside and affixed to, whether temporary or permanent, lighted or unlighted, intended to be viewed from the exterior of the building. The term does not include advertising located within the building.

SECTION XXXX:

That Title 18 Appendix (CARSON CITY DEVELOPMENT STANDARDS), Division 4 (SIGNS), Section 4.4 (Administration) is hereby amended (**bold, underlined** text is added, [~~stricken~~] text is deleted) as follows:

4.4 Administration.

4.4.1 Permit required. It is unlawful for any person to erect, construct, enlarge, alter, or relocate within Carson City any sign or other advertising structure as defined in this division or to install or alter any electrical wiring or fixture therein without first having obtained a permit from the building division.

Billboards or off-premise signs shall obtain a special use permit approval and a business license for each sign.

4.4.2 Application for permit. Application for sign permits shall be made at the building division on forms provided by the division and shall contain or have attached thereto the required information and material including:

- a. Name, address and telephone numbers of the owner of the property;
- b. Name, address and telephone numbers of the applicant (owner of sign);
- c. Name, address and telephone numbers of sign contractor if required;
- d. Location of building, structure and lot to which or upon which the sign or other advertising structure is to be attached or erected, and the lineal frontage of the building or suite which faces the street or parking area, as applicable;
- e. Three (3) copies of plans showing:
 - (1) Position of sign or other advertising structure in relation to adjacent buildings or structures.

- (2) The design and size, type of materials to be used, structural details and the calculations, colors proposed, and proposed location on the premises of such sign or sign structure.
 - (3) An exhibit showing or describing the size and dimensions of all existing and proposed signs on the premises at the time of making such application;
- f. An assessment of the valuation of the proposed sign(s) material and labor (installation).

4.4.3 Issuance of permits. The building division and community development department shall check the application, plans and specifications for sign permits. No permit shall be issued unless the plans and specifications have been reviewed and approved by all pertinent city departments as being in conformance with pertinent laws and ordinances under their jurisdiction. If the plans and specifications conform to the requirements of this division and other pertinent laws and ordinances, and the specified fee has been paid, then the permit shall be issued. If it is determined from the application or from the inspection of the premises that signs or other advertising structures exist in excess of allowances, no permit shall be issued for any new sign or advertising structure which would increase the gross size or dimensional area of all signs or advertising structures beyond the allowable limits of this Division.

4.4.4 Inspection. Every sign erected in Carson City shall be subject to inspection by the building division for compliance with the latest adopted editions of the applicable building and electrical codes. All electric signs require inspection and approval of wiring and electrical fixtures before they may be connected to the electrical power source.

4.4.5 Schedule of permit fees. Fees for sign permits shall be based upon the fee schedule as currently adopted by Carson City.

4.4.6 Fee for electrical inspection. Fees for electrical inspection shall be based upon the fee schedule as currently adopted by Carson City.

4.4.7 Exemptions. The following signs are exempted from all other provisions of this division except as noted.

- a. Professional occupation signs denoting only the name, firm name and profession of an occupant in a commercial building, public institutional building or dwelling house when the area of such signs does not exceed two (2) square feet for each professional occupant therein;
 - b. Memorial signs or tablets, historical reference signs, names of buildings and dates of erection when cut into any masonry surface or when constructed of bronze or other incombustible material and permanently fastened to the building or structure;
 - c. Identification nameplates or signs on apartment houses, rooming houses and trailer parks, public telephones and similar uses not exceeding four (4) square feet in area;
 - d. Bulletin boards not over fifteen (15) square feet in area for public charitable and religious institutions when such bulletin boards are located on the premises of said institutions;
 - e. Community directory sign or community directional sign;
- (1) Prior to the installation of any such structures, the location, size, height, width and general design shall have been approved by the commission as being in

conformance with the general purpose of this division through commission review procedure.

- f. Any sign denoting the name of any political campaign, charitable organization or religious institution, provided that:
 - (1) The area of such sign shall not exceed thirty-two (32) square feet;
 - (2) The height of a freestanding sign shall not exceed eight (8) feet;
 - (3) Political signs shall be removed by the candidate within fourteen (14) days after the election has been held;
- g. Off-site temporary signs and banners of a civic, charitable, educational, municipal or religious nature not to exceed a period of thirty (30) consecutive days within any ninety-day period; planning and community development shall be notified by the applicant prior to installation of any such sign;
- h. Temporary promotional window signs on the interior of windows or temporarily painted on the outside of windows that provide information about a specific product, price, event, or activity;
- i. The changing of advertising copy of message on a reader board, theater marquee and/or similar sign, specifically designed for the use of replaceable copy;
- j. On-premise "open," "closed," "vacancy," or "no vacancy" signs not exceeding four (4) square feet in area;
- k. Directional signs which do not exceed three (3) feet in overall height and two (2) square feet in sign area;
- l. Garage sales. Temporary signs for a noncommercial garage sale, provided that they are removed within twenty-four (24) hours of the end of the sale date by the individuals conducting the sale. Such signs shall not be placed on traffic control signs or utility poles;
- m. On-premise real property signs (including future tenants, "for sale," "for rent," "open house," etc.) are permitted subject to the following conditions:
 - (1) Parcels of five (5) acres or more in any land use district may have signs which do not exceed thirty-two (32) square feet of total surface area.
 - (2) Parcels of less than five (5) acres may have signs which do not exceed six (6) square feet in residential districts, or twenty (20) square feet in nonresidential districts.
 - (3) Signs shall not exceed eight (8) feet in height above average ground level.
 - (4) Not more than one (1) sign shall be allowed on each parcel of land. If the property is located on two (2) street frontages, one (1) sign is permitted on each street frontage. One (1) additional on-site "open house" sign per street frontage is permitted during open house events described in subparagraph (5), below. On-site signs may include flags, streamers, balloons or similar devices during such events.
 - (5) In addition to the on-premise signs permitted above, off-premise "open house" signs may be placed subject to the following conditions:

- (a) The signs must be for a designated open house that is listed for sale or lease.
 - (b) The overall height of a sign must not exceed thirty-six (36) inches from the ground to the top of the sign, and the sign area must not have a horizontal dimension of more than twenty-four (24) inches and a vertical dimension of more than eighteen (18) inches.
 - (c) Signs shall have no riders with the exception of the listing agent's name and/or firm's name; no additions, tags, streamers, balloons or other appurtenances may be added to the sign. Directional arrows may be incorporated into the permitted sign face area but may not be added appurtenant to the sign.
 - (d) No more than three (3) off-premise open house signs shall be allowed per open house. Additional off-premise signs are allowed upon prior approval of the Planning Director or his designee if the open house is more than one (1) mile (closest travel distance) from an arterial street, as designated on the Carson City Roadway Functional Classification map.
 - (e) Signs may be displayed on the day of the open house from 8:00 a.m. to 6:00 p.m. while the home is open to the public and shall be removed by 6:00 p.m. or when the open house is closed, whichever comes first.
 - (f) No sign shall be placed on public property including State right-of-way. A sign may be placed within city right-of-way behind the curb and sidewalk but may not be placed on a sidewalk, in a street, on or within a median strip, traffic island or center roadway divider, or within a traffic safety site area. Signs shall not be attached to trees, utility poles or traffic control devices.
 - (g) No more than two (2) different open house signs may be placed at a single street intersection, with preference given to the first two (2) legal signs placed at the intersection.
- n. Construction signs are permitted subject to the following conditions:
- (1) In nonresidential zones: One (1) sign advertising the various construction trades on any construction site. Such signs shall not exceed one hundred (100) square feet in area, shall not be installed prior to the start of construction, and shall be removed before occupancy of the site.
 - (2) In agricultural and residential zones: One (1) sign advertising the various construction trades on any construction site. Such signs shall not exceed thirty-two (32) square feet in area, shall not be installed prior to the start of construction, and shall be removed before occupancy.
- o. Replacement of sign panels which do not involve the electrical or structural modification of an existing sign structure.
- p. Pennants located on private property. The following specific standards shall apply to all pennants:

- (1) The maximum collective length of such advertising devices across the subject parcel shall not exceed three (3) times the width of the parcel facing a public right-of-way.
 - (2) Each individual pennant shall not exceed eighteen (18) inches in length.
 - (3) Strings of pennants shall not exceed the height of any buildings on the subject site, if no buildings are present, the maximum height shall be twenty (20) feet. Pennants shall be maintained in good condition.
- q. Except as otherwise provided in these development standards, inflatable devices located on private property provided that the inflatable device is used in conjunction with a special event where a special event permit has been obtained pursuant to Chapter 4.04 (Business Licenses) of the Carson City Municipal Code, subject to the time limitation and any other limitations of the special event permit. The maximum height of such devices shall not exceed the height of any buildings on the subject site or twenty (20) feet, whichever is less. Inflatable devices shall be anchored securely and shall not interfere with pedestrian access, vehicular traffic movements, or traffic control devices.
- r. Balloons located on private property provided that the maximum height of such devices shall not exceed the height of any buildings on the subject site or twenty (20) feet, whichever is less. Balloons shall be anchored securely and shall not interfere with pedestrian access, vehicular traffic movements, or traffic control devices, and shall be maintained in good condition.
- s. Banners located on private property. The following specific standards shall apply to all banners:
- (1) One (1) banner per business is allowed.
 - (2) Banners for businesses with less than ten thousand (10,000) square feet of gross floor area shall not exceed fifty (50) square feet. An additional twenty-five (25) square feet of banner area is permitted per twenty thousand (20,000) square feet of gross floor area over ten thousand (10,000) square feet up to a maximum banner area of two hundred (200) square feet.
 - (3) Banners shall be securely attached to the primary structure or permitted freestanding sign. No freestanding banners are permitted.
 - (4) Only one banner or promotional flag may be used by a business at any given time.
 - (5) Notwithstanding the size limitations above, a new business may utilize a banner of one hundred (100) square feet or a size permitted under subparagraph (2), whichever is greater, for up to ninety (90) consecutive days upon the opening of the business.
 - (6) Except as otherwise provided in this subparagraph, a banner may not be used in lieu of a permanent sign at any time sixty (60) days after the date on which the business to which the banner relates is first open for business. A banner may be used by a business in lieu of a permanent sign for a period not to exceed sixty (60) days, unless otherwise approved by the Carson City Planning and Community Development Director, if it is reasonably necessary to remove the permanent sign

for purposes of construction or to make an improvement on the building to which the permanent sign is affixed.

- t. Changeable promotional flags or feather flags located on private property subject to the following standards:
 - (1) One (1) flag per business.
 - (2) A flag shall not exceed a total size of twelve (12) square feet.
 - (3) A flag shall be securely attached to the primary structure in which the business is located. No freestanding flags are permitted except when used in conjunction with a special event where a special event permit has been obtained pursuant to Chapter 4.04 (Business Licenses) of the Carson City Municipal Code, subject to the time limitation and any other limitations of the special event permit.
 - (4) Any flag displayed above a pedestrian area shall be maintained so that its lowest point is no less than eight (8) feet above the pedestrian ground surface.
 - (5) Only one (1) promotional flag or banner may be used by a business at any time.
- u. Signs within NDOT right-of-way in compliance with state sign regulations.
- v. Official flags flown in accordance with protocol established by the United States Congress; and corporate flags that may contain a business logo when flown on a flagpole with an official flag, provided that the corporate flag does not exceed forty-eight (48) square feet or the size of the official flag, whichever is less.
- w. One (1) off-premise electronic message display sign, if such sign:
 - (1) Is owned by a community college, state college or university within the Nevada System of Higher Education, which by this exemption is deemed to be an important community asset;
 - (2) Is located within one (1) mile of the community college, state college or university that owns the sign;
 - (3) Is located on an arterial street, as designated on the Carson City Roadway Functional Classification map;
 - (4) Does not exceed twenty (20) feet in height;
 - (5) Does not exceed ninety (90) square feet in area for the electronic message display portion of the sign and one hundred twenty (120) square feet in total sign area; and
 - (6) Complies with the provisions of Section 4.6.6 of this Appendix.
- x. Notwithstanding any other provision of this division, A-frame signs are subject to the following standards:
 - (1) One (1) A-Frame sign is permitted per business.
 - (2) The sign must be placed within twenty (20) feet of the doorway to the business.
 - (3) If placed on a pedestrian sidewalk or walkway, a minimum of six (6) feet of unobstructed sidewalk clearance must be maintained.

- (4) Signs must be professionally manufactured and shall not exceed thirty-two (32) inches in width and thirty-six (36) inches in height. Chalkboard frames with erasable letters are also allowed.
- (5) All signs shall be in good repair and neatly painted. Attachments to signs are prohibited.
- (6) Signs shall not be displayed during non-business hours.
- (7) Signs may not be located in any area or in any manner such that obstruction of the line of sight for passing motorists or within proximity to a driveway occurs.

4.4.8 Duty to enforce. It is the duty of the building division and community development department to enforce all of the provisions of this division.

4.4.9 Interference with enforcement. It is unlawful to interfere with the building inspector or compliance officer in the performance of their duties and enforcement of this division.

4.4.10 Compliance with ordinance-nuisance-abatement. The board hereby determines that the public peace, safety, morals, health and welfare require that all signs and advertising structures heretofore constructed or erected are hereby made subject to the provisions of this division, and shall conform to this division. Any new sign not in compliance shall be deemed a public nuisance and must be removed and abated in the manner provided by the law.

4.4.11 Illegal signs. Any sign erected in violation of laws in effect at time of erection is an illegal sign and shall be removed immediately by the responsible persons upon notification.

4.4.12 Exception—Official signs, safety signs, "OSHA" requirements. Nothing contained in this division shall prevent the erection, construction and maintenance of official traffic safety, fire and police signs, signals, devices and markings of the Nevada Department of Transportation (NDOT), the Carson City Public Works Department, the board or other competent public authorities, nor the posting of notices required by law. Similarly, on-premise regulation signs and signs necessary for the safety of those members of the public using said premises, whether said signs are officially or privately erected, are not subject to the provisions of this division.

4.4.13 Non-conforming signs. All non-conforming signs will be removed from the premises or brought into conformance with the requirements of this division upon the expansion of an existing building which exceeds twenty (20) percent of the gross floor area of the existing building or one thousand (1,000) square feet, whichever is greater, or upon replacement, damage or destruction of the sign structure that exceed fifty (50) percent of the total sign valuation (replacement cost), or upon a change in the design of the sign display area, including a change in size, shape or proportions, unless the non-conforming sign is approved by special use permit.

4.4.14 Appeal to commission.

- a. Appeals. Any person aggrieved by the denial of:
 - (1) Issuance of a building permit; or
 - (2) Any other decision of an administrative officer under the authority of this division, or any officer or agency of Carson City, may appeal from such denial, issuance or decision to the commission.

- b. Filing. An appeal may be made within ten (10) calendar days after the denial or issuance of the permit or the rendering of the decision by filing a written statement of the reasons why the denial, issuance or decision is erroneous.
- c. Hearing. The commission shall hear the appeal and render a decision within sixty (60) calendar days after the filing of the statement of reasons. The commission shall give ten (10) calendar days written notice of the date, time and place of the hearing to the applicant and parties involved in the application. The commission may uphold or modify the administrative officer's decision.
- d. Appeals of the commission's decision shall be made to the board within ten (10) calendar days after the decision.
- e. Anyone desiring to appeal to a court of law after the final decision of the board shall do so in the manner provided by and in accordance with state law.

4.4.15 Penalty for violations.

- a. Any person, firm or corporation, whether as principal, agent, employee, or other-wise, violating any provision of this division or violating or failing to comply with any order or regulation made hereunder is guilty of a misdemeanor, and upon conviction thereof shall be punished by the penalty prescribed in Section 1.08.010 of the Carson City Municipal Code.
- b. Such person, firm or corporation may be deemed guilty of a separate offense for each and every day during which such violation of this division or failure to comply with any order or regulation is committed, continued or otherwise maintained.

4.4.16 Maintenance. All signs shall be maintained by the responsible party in good order and repair at all times and shall be kept free of peeling paint, faded materials, major cracks, tear and/or dangling materials. All canister type signs missing a sign panel insert shall be placed with a blank insert within thirty (30) days of notification.

4.4.17 Construction and safety.

- a. All signs requiring a permit in Carson City shall be regulated by the Sign Code as currently adopted by Carson City and any other applicable building, electrical and fire prevention codes as adopted by the board and administered by the building department.
- b. If a permit is not required, signs shall be safely erected and maintained as specified by the Sign Code as currently adopted by Carson City and any other applicable building, electrical and fire prevention codes as adopted by the board and administered by the building division.

SECTION XXXX:

That Title 18 Appendix (CARSON CITY DEVELOPMENT STANDARDS), Division 4 (SIGNS), Section 4.5 (Restricted and/or prohibited signs) is hereby amended (**bold, underlined** text is added, [~~stricken~~] text is deleted) as follows:

4.5 Restricted and/or prohibited signs.

- 4.5.1 Signs on trees, shrubs, traffic control signs, or utility poles. No signs shall be affixed to trees, shrubs, traffic control signs or support structures, utility poles, or any structure within the public right-of-way except as expressly permitted by other provisions of this division.
- 4.5.2 Rotating and revolving signs. Rotating and revolving signs may be permitted for commercial/shopping center uses with the following restrictions:
- a. Maximum speed. Maximum speed of revolution or motion of a sign or any part of a sign may not exceed five (5) revolutions or cycles per minute.
 - b. Non-Flashing. No rotating, revolving or moving sign or part of a sign shall be illuminated in whole or in part by any flashing or intermittent light or light source.
 - c. Location Restrictions. If the majority of adjacent property on the same side of the street contains a residence, apartment, hospital, or home for the aged or convalescent located within 100 feet line-of-sight distance on the opposite side of the street or intersection, or there is such land use within 200 feet line-of-sight distance of the opposite side of the street or intersection, no rotating or revolving or moving sign shall be permitted to be illuminated after 10:00 p.m. or before 7:00 a.m., unless the rotation or other movement is stopped, and all light from such a sign is steady and continuous.
- 4.5.3 Flashing Signs. Flashing signs are permitted only with the following restrictions:
- a. Non-Rotating or Moving. Where a flashing sign or intermittent source of sign illumination is allowed, such sign may not revolve, rotate or move in any other manner.
 - b. Light Source Restrictions. No strobe lights or zip lights shall be permitted. Exposed incandescent bulbs may be used on the exterior surface of a sign if each such bulb does not exceed 25 watts (incandescent light equivalent).
 - c. Locations Restrictions. If adjacent property on the same side of the street contains a residence, apartment or hospital, or home for the aged or convalescent located within 200 feet line-of-sight distance of the sign, or there is such land use within 200 feet line-of-sight distance of the opposite side of the street or intersection, no sign shall be permitted to flash or appear to flash. This does not preclude time and temperature signs or scoreboards.
- 4.5.4 Spot-Lights or Rotary Beacons. Spot-lights or rotary beacons may be located at any shopping center or individual commercial location providing such devices are maintained for more than 1 time period, not to exceed 7 consecutive days in any 60 day period.
- 4.5.5 Abandoned Signs. No persons shall maintain or permit to be maintained on any premises owned or controlled by them any sign which has been abandoned. Any such sign shall promptly be removed by the owner. Any sign which is located on property which becomes vacant and unoccupied for a period of 6 months or more, or any sign which was erected for an occupant or business unrelated to the present occupant or their business, or any sign which pertains to a time, event or purpose which no longer applies shall be presumed to have been abandoned, except that permanent signs applicable to a business temporarily suspended by reason of change of ownership or management of such business shall not be considered abandoned unless the property remains vacant for a period of 12

months. If the sign is not removed within the above time limits, the city will remove the sign at the expense of the property owner.

4.5.6 Advertising By Vehicle. No sign shall be erected upon or attached to any vehicle unless painted directly upon the vehicle's surface or magnetically attached thereto. The primary use of such vehicles shall be in the operation of the business and not for the purpose of directing (graphically) patrons to the location of the business premises. The provisions of this section shall not be applicable to signs affixed to vehicles of public carriers operating within the city.

4.5.7 Illuminated Delivery Vehicle Signs. Delivery vehicle identification signs may be internally illuminated, but shall not exceed 3 square feet in area. The provisions of this section shall not be applicable to signs affixed to vehicles of public carriers operating within the city.

4.5.8 Changeable Promotional Signs. Changeable promotional signs are permitted accessory to a permanent sign(s) for all commercial/shopping center uses subject to the following standards:

- a. The sign must have a permanent framework structure. The framework structure shall be compatible with the materials and colors of the primary structure. A PVC-type material framework is not permitted.
- b. The square footage of all changeable promotional signs shall be counted toward the maximum square footage of signs allowed for a use and shall not exceed 25% of the total allowable sign area.
- c. No more than 2 permanent changeable copy signs shall be permitted per site.
- d. The changeable portion of the sign structure must be an all-weather material, such as vinyl, canvas or other material as approved by planning and community development.

4.5.9 Cards, Posters, Handbills. It is unlawful for any person to paste, post, paint, print, nail, tack or otherwise fasten any card, banner, handbill, sign, poster, advertisement or notice of any kind upon any property or vehicle without the consent of the owner, holder, lessee, agent or trustee thereof.

4.5.10 Roof-Mounted Signs. Roof-mounted signs are prohibited.

4.5.11 Billboards and Off-Premise Signs. Billboards and off-premise signs are permitted if:

- a. A special use permit has been issued for the sign in accordance with the general special use permit standards set forth in CCMC Title 18; and
- b. The sign complies with the billboard and off-premise signs provisions of this division.

4.5.12 Window Signs. Window signs shall be prohibited except where included in maximum allowable area of advertising sign or as provided in Section 4.4.7(h).

4.5.13 Parapet Signs. Parapet signs extending above the building parapet are prohibited.

4.5.14 Imitation Signs. No sign shall be erected or located in a manner which would:

- a. Imitate a traffic or directional sign;
- b. Cause a hazard to movement of vehicles or pedestrians upon public rights-of-way;

- c. Obstruct or interfere with the view of a traffic sign, signal or other safety device located upon a public right-of-way.
- 4.5.15 Obscene Signs. All signs shall comply with all state of Nevada laws regulating obscenity.
- 4.5.16 Areas Where Signs Are Not Permitted.
- a. Along both sides of the right-of-way of U.S. Highway 50 West from the Carson City line easterly to the range line between R.19 E. and R.20 E. and along both sides of the right-of-way of State Route 28 (Lake Tahoe) within Carson City;
 - b. Within any stream or drainage channel;
 - c. Within 100 feet from any highway intersection if such location would obstruct vision to vehicular traffic;
 - d. Which may prevent a traveler on a highway from obtaining a clear view of approaching traffic for a distance of not less than 500 feet.
- 4.5.17 Portable Signs. Portable signs are prohibited unless carried by a person on private property to advertise a business located on the same property for no more than 3 days within a calendar month.

SECTION XXXX:

That Title 18 Appendix (CARSON CITY DEVELOPMENT STANDARDS), Division 4 (SIGNS), Section 4.6 (General regulations and standards) is hereby amended (**bold, underlined** text is added, [~~stricken~~] text is deleted) as follows:

4.6 General regulations and standards.

- 4.6.1 Application. The provisions set forth in this section shall be applicable to all signs permitted by this ordinance except where specific regulations contrary to this section are established.
- 4.6.2 Computation of Sign Area.
- a. In computing maximum permissible sign area or display surface, all signs designed to be seen from off the premises upon which the sign is proposed to be located shall be included; 1 face of a double-faced sign shall be used for calculation, in the event that a sign contains more than 2 faces, each additional face shall be calculated separately. Sign area computation includes any portion of the sign display surface area on which the sign copy appears.
 - b. Signs may be permitted on each street frontage of the maximum size allowed for the street frontage being used for calculating the sign size. The regulations and standards by use (Section 4.7) shall govern as to size of signs.
 - c. Sign area shall be calculated in the manner illustrated in diagram A, made a part hereof.

- d. The maximum sign area for a use shall be calculated based on the lineal frontage of a single building side facing any adjacent public street or common parking area. For uses located on properties with multiple street frontages each building frontage facing a street frontage may be used for purposes of calculating the maximum allowable sign area.

Diagram A

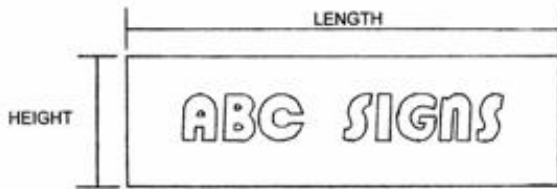

All signs are calculated Height X Length



Signs with individual letters are measured by enclosing the area around them as if in a frame

4.6.3 Number of Freestanding Signs.

- a. A maximum of 1 freestanding sign is allowed for a shopping center or commercial use. A shopping center or commercial use located on an arterial street, as designated on the Carson City Roadway Functional Classification map, which has 2 or more street frontages is allowed 1 additional freestanding monument type sign which does not exceed a maximum of 6 feet in height and a maximum of 36 square feet in sign area on the secondary frontage.
- b. For all other uses, except for new automobile dealerships, which are permitted to have a freestanding sign under the provisions of Section 4.7 of this ordinance, a maximum of 1 freestanding sign is allowed.
- c. Pursuant to Section 4.7.8, the number of freestanding signs allowed in this category is 1 freestanding sign per manufacturer line of vehicle and 1 secondary freestanding sign if the new automobile dealership is adjacent to a side or rear street.

4.6.4 Minimum Height Clearance. The minimum height clearance for any sign shall not be less than 8 feet above the ground where pedestrian traffic may occur underneath the sign nor less than 14 feet above any driveway, alleyway or other way designed for vehicular traffic.

4.6.5 Variation from Certain Regulations and Standards. Variations to the regulations and standards of division 4.7 (Regulations and Standards by Use) may only be permitted by special use permit, approval of which shall be pursuant to Title 18, Section 18.02 (Special Use Permits).

4.6.6 Electronic Message Display Signs. A sign that displays electronic messages must comply with each of the following requirements:

- a. The portion of the sign that displays an electronic message must be equipped with technology that automatically dims the display according to ambient light conditions. The brightness of the sign at full white screen must be limited to 0.3 foot-candles over ambient light, measured at a distance of 10 times the square root of the area of the sign.
- b. The sign must have a message hold time that is three seconds or longer. As used in this subsection, "message hold time" means the time a message is displayed on the sign before the sign transitions to display another message.
- c. The transition time between different messages being displayed on the sign must not exceed one second.
- d. Except as otherwise provided in this subsection, a sign that displays electronic messages may also display video graphics. However, any such graphics must comply with any other operational parameters for the sign that are applicable.
- e. The sign must not emit any sound.

SECTION XXXX:

That Title 18 Appendix (CARSON CITY DEVELOPMENT STANDARDS), Division 4 (SIGNS), Section 4.7 (Regulations and standards by use) is hereby amended (**bold, underlined** text is added, [~~stricken~~] text is deleted) as follows:

4.7 Regulations and standards by use.

4.7.1 Agricultural and Single-Family Residential Uses. In agricultural and single-family residential areas as defined in Title 18 and the development standards, 1 identification sign not exceeding 2 square feet in area denoting the name and address of the occupant shall be permitted subject to the following regulations:

- a. Maximum sign height shall be the height of the building facade or roof eave;
- b. Illumination shall be by indirect lighting only;
- c. Sign materials shall be compatible with the building to which it is attached.

4.7.2 Multifamily Residential Uses.

- a. Permitted signs:
 - (1) 1 sign denoting the name of the multi-family residential use either freestanding or attached, not exceeding 32 square feet in area;
 - (2) 1 address sign not exceeding 4 square feet in area for the entire site;
 - (3) 1 address sign not exceeding 2 square feet for each unit within the complex.
- b. The maximum height of a freestanding sign shall be 6 feet in any residential or office zoning district; 15 feet in any other zoning district.
- c. Illumination of signs shall be by indirect lighting only.

- d. Sign materials shall be compatible with the primary on-site building.

4.7.3 Office Building Uses.

- a. Permitted signs:
 - (1) 1 freestanding sign not to exceed a maximum of 32 square feet;
 - (2) Wall sign(s) measuring 1 square foot for each lineal foot of building frontage not to exceed a maximum of 15 feet per street frontage;
 - (3) 1 wall directory sign, not to exceed a maximum of 1 square foot of sign area for each occupant of an office building;
 - (4) 1 address sign not exceeding 4 square feet in area.
- b. The maximum freestanding sign height shall be 6 feet in the Residential Office or General Office zoning districts and 20 feet in any other non-residential zoning district.
- c. Illumination from or upon any signs in Residential or General Office zoning districts shall be of such a light intensity or brightness that does not distribute light on adjacent areas.
- d. Materials and design shall be compatible with the primary on-site building.

4.7.4 Shopping Center Uses.

- a. A freestanding sign identifying the shopping center is intended as the primary identification sign. Signs on individual businesses within the shopping center are secondary signs intended to direct shoppers within the complex.
- b. Permitted signs and maximum sign area shall be as follows:
 - (1) Freestanding sign(s) pursuant to Section 4.6.3 denoting the name of the complex, which may also be a combination sign depicting individual businesses with the complex and not exceeding 300 square feet in area.

The shopping center name is exempt from the sign area calculation when limited to 30 square feet (10% of the total permitted sign area);
 - (2) Permitted sign area for individual signs for each business/tenant in the complex shall be calculated based on a ratio of 3 square feet for every 1 foot of the frontage of building/suite for the first 100 feet of frontage. Sign area shall be calculated on a ratio of 1 square foot for every 1 foot of the frontage of the building/suite for the portion of the frontage exceeding the first 100 feet up to a maximum sign area of 600 feet;
 - (3) 1 address sign on each street frontage not to exceed 4 square feet;
 - (4) Regardless of the amount of the frontage of a building/suite, each building/suite is entitled to a minimum of 50 square feet of wall signs.
- c. Maximum height for a freestanding sign shall be 30 feet.
- d. Illumination from or upon any sign shall be shaded, shielded, directed or reduced so as to avoid undue brightness, glare, or reflections of light. The intent is to make the sign reasonably visible to the average person on an adjacent street.

- e. Sign materials shall be integrated into, and compatible with, the design of the shopping center.

4.7.5 Other Commercial Uses.

- a. Permitted signs and maximum sign area shall be as follows:
 - (1) Permitted sign area for the parcel shall be calculated based on a ratio of 3 square feet for every 1 foot of the frontage of building for the first 100 feet of frontage. Sign area shall be calculated on a ratio of 1 square foot for every 1 foot of the frontage of the building/suite for the portion of the frontage exceeding the first 100 feet up to a maximum sign area of 600 feet;
 - (2) 1 address sign not exceeding 4 square feet in area;
 - (3) A maximum of 50 percent of the total allowable sign area may be located on the freestanding sign pursuant to Section 4.6.3.
- b. Maximum sign height of the freestanding sign shall be 20 feet.
- c. Illumination from or upon any sign shall be shaded, shielded, directed or reduced so as to avoid undue brightness, glare or reflection of lights.
- d. Sign materials shall be compatible with the design of the primary on-site building.
- e. Regardless of the amount of the frontage of the building or suite, each business is entitled to a minimum of 80 square feet of signs.
- f. 1 downtown business directory sign, platform, or pole, is permitted per intersection, which shall encompass all corners, within the downtown area subject to approval of a special use permit. All sign platforms or poles must be consistent in construction and appearance. Individual signs for businesses are limited to a maximum of 1 square foot with a maximum letter height of 3 inches and must be constructed on the single platform or pole. Downtown business directory signs are intended to assist pedestrians to locate downtown businesses. Approval of an encroachment permit from the Nevada Department of Transportation and/or the Carson City Development Services Engineering is required prior to the city's approval of the sign permit.

4.7.6 Signs For Manufacturing/Industrial Uses. This section applies only to manufacturing and industrial uses as defined in Title 18 and the development standards.

- a. Permitted signs and maximum sign area shall be as follows:
 - (1) Signs shall not exceed a ratio of 3 square feet for every 1 lineal foot of the frontage of the building not to exceed a maximum of 200 square feet;
 - (2) 1 address sign not exceeding 4 square feet;
 - (3) 1 freestanding sign.
- b. Maximum height of freestanding sign shall be 10 feet.
- c. Materials and sign design shall be compatible with the primary on-site building.

4.7.7 Area Identification Signs. Permanent area identification signs may be erected subject to the following conditions:

- a. Maximum Area. The total surface area shall not exceed 100 square feet;
- b. Maximum Height. The maximum height of a freestanding sign shall not exceed 10 feet;
- c. Materials and sign design shall be compatible with the immediate surroundings.

4.7.8 New Automobile Dealership Uses.

a. Permitted Signs:

- (1) 1 freestanding sign is permitted for each manufacturer line of new automobiles and the sign(s) shall not exceed 200 square feet in size and not more than 32 feet in height.

The dealership may exchange 1 of the manufacturer line of new automobiles signs for a reader-board sign which shall not exceed 200 square feet in size and not more than 32 feet in height.

- (2) Should the new automobile dealership be adjacent to a side or rear street, one secondary sign per street is allowed and shall not exceed 80 square feet and shall not exceed 20 feet in height.

- b. Permitted sign area for the parcel shall be calculated based on a ratio of three feet for every one foot of the frontage of the building parallel to a street and one square foot of signage for each square foot of new automobile display area; for a total maximum signage area of 850 square feet for a new automobile dealership, including all building and freestanding signage.

- c. A maximum of up to 50 percent of the total allowable sign area may be located on freestanding signs pursuant to Section 4.6.3(c).

- d. Maximum sign height of dealership primary signs shall be 32 feet.

- e. Illumination from any sign must be shaded, shielded, directed or reduced so as to produce excessive brightness, glare, or reflection of lights.

- f. Sign materials must be compatible with the design of the display area portion of the main building.

- g. All sign platforms and/or poles must be consistent in construction and appearance.

h. Other Permitted Uses:

- (1) Address signs of a maximum of 4 square feet.
- (2) Directional signs which do not exceed 3 feet in height and 4 square feet in sign area.
- (3) Pennants located on private property. The following specific standards shall apply to all pennants:
 - a. The maximum collective length of such advertising devices across the subject parcel shall not exceed three times the width of the parcel facing a public right-of-way.
 - b. Each individual pennant shall not exceed 18 inches in length.

- c. Strings of pennants shall not exceed the height of any buildings on the subject site and, if no buildings are present, the maximum height shall be 20 feet. Pennants shall be maintained in good condition.
- (4) Large inflatable devices located on private property providing such devices are not used for a period in excess of twelve days within any calendar month and provided that the maximum height of such devices shall not exceed the height of any buildings on the subject site or 20 feet, whichever is less. Inflatable devices shall be anchored securely and shall not interfere with pedestrian access sidewalks, vehicular traffic movements, or traffic control devices.
 - (5) Balloons located on private property provided that the maximum height of such devices shall not exceed the height of any buildings on the subject site or 20 feet, whichever is less. Balloons shall be anchored securely and shall not interfere with pedestrian access sidewalks, vehicular traffic movements, or traffic control devices, and shall be maintained in good condition.
 - (6) Banners located on private property providing such devices are not used for a period in excess of 30 consecutive days within any 90 day period. The following specific standards shall apply to all banners:
 - a. One banner per building elevation per unit of operation or business is allowed, with a maximum of two banners per business.
 - b. Banners for businesses with less than 10,000 square feet of gross floor area shall not exceed 50 square feet. An additional 25 square feet of banner area is permitted per 20,000 square feet of gross floor area over 10,000 square feet up to a maximum banner area of 200 square feet.
 - c. Banners shall be securely attached to the primary structure or on bollards within the new automobile dealership's front yard. The bollards design shall be approved by the Director prior to use.
 - d. Any banner used for a period exceeding 30 days in any 90-day period may be allowed subject to the provisions of Section 4.5.8, Changeable Promotional Signs.
 - (7) Changeable promotional flags located on private property provided such flags are not used for a period in excess of 30 consecutive days within any 90 day period. Any flag maintained in excess of 30 days may be allowed subject to the following standards:
 - a. Flags must be spaced at 15 foot intervals across the front property line of the business.
 - b. Flags shall not exceed a total size of 10 square feet.
 - c. Flags will be securely attached to the primary structure. Freestanding flags are permitted with the approval of the Director.
 - d. Any flag displayed above a pedestrian area shall be maintained so that its lowest point is no less than eight feet above the pedestrian ground surface.

- (8) Signs within NDOT right-of-way must be in compliance with state sign regulations.
- (9) Official flags may be flown in accordance with protocol established by the United States Congress and corporate flags that may contain a business logo may be flown on a flagpole with an official flag, provided that the corporate flag does not exceed 80 square feet or the size of the official flag, whichever is less.
- i. Administrative Variances. Allowances for additional height and signage may be allowed if less than 10 percent as an administrative variance by the director, and if more than 10 percent, then by a special use permit pursuant.

SECTION XXXX:

That Title 18 Appendix (CARSON CITY DEVELOPMENT STANDARDS), Division 4 (SIGNS), Section 4.8 (Requirements for billboards and off-premises signs) is hereby amended (**bold, underlined** text is added, [~~stricken~~] text is deleted) as follows:

4.8 Requirements for billboards and off-premises signs.

4.8.1 Name. This chapter shall be called the off-premises sign regulations.

4.8.2 Findings.

- a. Comprehensive Regulation of Off-Premises Advertising. The Board finds and declares that the purpose of developing requirements for billboards and off-premises signs is to establish a comprehensive system for the regulation of the time, manner and place of the commercial use of billboards and off-premises signs and the gradual elimination of nonconforming off-premises signs through attrition and natural deterioration. Illegal billboards and off-premises signs are public nuisances, and unless the status is changed under this chapter to nonconformance, shall be removed and abated in the manner provided by law. It is intended that these regulations:
 - (1) Impose reasonable standards on the number (density), size, height and location of billboards and off-premises signs and facilitate removing or bringing into conformance existing illegal and nonconforming billboards and off-premises signs in order to:
 - (a) Prevent and relieve distraction and clutter resulting from excessive and confusing billboard displays,
 - (b) Safeguard and enhance property values,
 - (c) Achieve the objectives of the Carson City Master Plan, and
 - (d) Promote the public safety and general welfare;
 - (2) Provide one (1) of the tools essential to the preservation and enhancement of the environment, thereby protecting an important aspect of the economy of Carson City which is instrumental in attracting those who come to live, visit, vacation and trade;

- (3) Eliminate hazards to pedestrian and motorists brought about by distracting and/or unsafe billboards and off-premises signs;
 - (4) Improve, enhance and preserve the appearance and other aesthetic qualities of Carson City.
- b. Findings and Purpose Supplementary to Other Chapters. These findings are supplementary to other statements of findings and purpose contained in this Division.
- c. Commercial Use Defined. Commercial use of billboards and signs, as used in this chapter, means and includes, without limitation, the use of signs having some or all of the characteristics and purposes listed in this section. These characteristics and purposes tend to describe the business practices and other arrangements of the persons who are engaged in the business of off-premises advertising, or of persons who use off-premises advertising in connection with their business and nonbusiness advertising, and therefore tends to describe the types of signs intended to be regulated by this chapter.
- (1) Signs on which advertising space is sold, leased, given or otherwise made available by the sign owner to other members of the public at large for the purpose of displaying the other person's message. The sign owner may or may not, but typically does, receive revenue or other value or benefits for allowing other persons to use the advertising space. The sign owner may or may not, but typically does not, own the land occupied by the sign;
 - (2) Signs which do not advertise the interests of the person who owns or occupies the land on which the sign is located, but which do advertise the interests of persons elsewhere. The sign message is determined by the sign owner or his lessee without regard for, and sometimes adverse to, the interests of the owners of the sign site;
 - (3) Signs owned and controlled by a person other than the person who owns or controls the land on which the sign is located;
 - (4) Signs which advertise interests or uses not present at the location of the sign;
- d. No Preferences Allowed to Particular Types of Messages.
- (1) Commercial use under this chapter is not determined by making reference to the content of the sign message to determine whether the sign advertises a commercial message or a noncommercial message. Noncommercial messages are those usually considered to be, for example, ideological, religious or political in nature. A noncommercial message does not cause a billboard or off-premises sign to no longer be a "commercial use" under this chapter. Commercial use is determined by making reference to the overall practices and arrangements of the sign owners and sign site owners in making the sign available to others.
 - (2) Nothing in this chapter may be construed to allow a commercial message any preference or greater protection over a noncommercial message, or to allow one (1) noncommercial message any preference or greater protection over another noncommercial message. Any reference to the message content of a billboard or off-premises sign, to the limited extent such reference is necessary, is made for

the sole purpose of classifying and segregating the two basic types of signs regulated in this Division:

- (a) Signs subject to the requirements of Division 4.8 and which are known variously as off-premises, off-site, nonappurtenant, nonaccessory, "outdoor advertising" or "billboards";
- (b) Signs subject to the other sections of Division 4 and which are known variously as on-premises, on-site, appurtenant, accessory and "business" signs.

4.8.3 New Billboards and Off-Premises Signs-Allowed Subject to Requirements.

a. Special Use Permit-Compliance with Other Restrictions.

- (1) A billboard or off-premises sign not in existence as of the effective date of the ordinance codified in this chapter may only be erected subject to the Special Use Permit process set forth in CCMC Title 18, the requirements set forth in this Division, CCMC Chapter 4.04 (Business Licenses), and all other applicable requirements of local, state and federal laws.
- (2) A Special Use Permit issued for a sign expires automatically five (5) years from the date of issuance.

b. Permitted Streets.

- (1) A sign may only be erected adjacent to the following existing streets:
 - (a) North and South Carson Street, between Douglas and Washoe Counties;
 - (b) US Highway 50, between Lyon County and North Carson Street.
 - (c) The south side of US Highway 50 West from the Douglas County line to six hundred sixty (660) feet (one-eighth ($\frac{1}{8}$) mile) east of that point within Section 31 of Township 15N., Range 20E.
- (2) New streets or portions of streets not yet constructed but which will have the same designations and descriptions as described in subdivisions (1)(a), (b) and (c) of this subsection are not permitted streets adjacent to which such signs may be erected.

c. Height.

- (1) Sign height may not exceed twenty-eight (28) feet from street elevation for new signs and from existing grade for existing signs. The street elevation to be used for measuring height is the permitted streets described in subsection 'b' of this section.
- (2) Existing signs having a height less than twenty-eight (28) feet may be increased to that height only if the sign conforms to all requirements of this chapter including, without limitation, the issuance of a Special Use Permit for the added height.
- (3) Appendages, cut-outs or other such components shall be allowed only where such appendage, cut-out or other such component:

- (a) Does not extend more than two (2) feet above the maximum height limitations set forth in this section; and
 - (b) The added sign area is not greater than ten (10) percent of the area of the maximum display surface set forth in Section 4.8.3(g).
- d. Number of Sign Faces on Each Structure—Position of Multiple Sign Faces.
 - (1) The supporting structure of a sign may not contain more than one (1) sign on each side of the structure, and each face must be parallel to the other face.
 - (2) Existing single-faced signs may have a second face added to the opposite side of the sign only if the sign conforms to all requirements of this chapter, including without limitation, the issuance of a Special Use Permit for the added sign face and the additional business license pursuant to Chapter 4.04 of the Carson City Municipal Code.
- e. Zoning of the Sign Site. The location of a sign must be zoned:
 - (1) General Commercial; or
 - (2) General Industrial.
- f. Spacing Distance from Other Off-Premises Signs. A sign may not be closer than one thousand (1,000) feet in any direction to another billboard or off-premises sign. The spacing distance shall be measured by circumscribing the area around the sign by a full circle having the sign at the center of the circle and having a radius equal to the spacing distance.
- g. Area of Sign.
 - (1) The area of a sign may not exceed four hundred (400) square feet.
 - (2) Existing signs having an area less than four hundred (400) square feet may be increased to that area only if the sign conforms to all requirements of this chapter including without limitation, the issuance of a Special Use Permit for the added sign area.
 - (3) Where an advertising display consists of individual letters, symbols, appendages, cut outs or other such components, or where such components are without an integrated background definition or are not within a single circumscribed frame area, it shall be deemed circumscribed by a line frame and shall not exceed the square foot limitation imposed by this chapter or by a Special Use Permit issued pursuant to this chapter.
- h. Setback from Certain Uses and Zoning. A sign may not be closer than three hundred (300) feet to property zoned Agricultural, Conservation Reserve, or Residential (single-family or multifamily).
- i. Setback from Redevelopment Area. A sign may not be located within one thousand (1,000) feet of the Carson City redevelopment project area as presently defined in this code.
- j. Prohibited Supporting Structures. A sign may not be attached to a roof or wall or other surface of a building. A sign must be a freestanding sign.

k. Prohibited Characteristics and Materials.

- (1) No three-dimensional objects and no movable reflective materials may be used on a sign.
- (2) A sign may be illuminated if:
 - (a) No direct rays of light project into residences or streets;
 - (b) The source of light is external from and not attached to or part of the display surface.
- (3) Flashing, animated or intermittent illumination is not allowed on a sign.
- (4) Moving or rotating parts or beams of light are not allowed on a sign.
- (5) Lights which simulate or create the effect of motion or which change numbers or letters are not allowed on a sign.

4.8.4 Existing Signs—Allowed to Continue in Existence Subject to Requirements.

- a. Special Use Permits for the continuance of a nonconforming sign are subject to denial or approval in accordance with the requirements for new signs as set forth in Section 4.8.3.
- b. A Special Use Permit for continuance of a nonconforming sign may not be denied on account of a sign failing to comply with the following requirements:
 - (1) The spacing distance specified in Section 4.8.3.(f)
 - (2) The setback distance from certain zoning areas and uses specified in Sections 4.8.3(h) and (i).
 - (3) The zoning requirement in Section 4.8.3(e).
- c. Any order to remove a sign adjacent to a primary or interstate highway is not effective unless the order has been submitted to the Nevada Department of Transportation (NDOT) for review and the Department has determined that the removal will not subject the State to highway funding penalty provided for in Title 23, United States Code, Section 131.

4.8.5 Maintenance and Repair of Signs.

- a. Reestablishment or Repair of Nonconforming Sign after Major Damage. A sign which does not conform to the requirements of this chapter for new signs may be continued in existence, repaired and maintained subject to the following limitations:
 - (1) A sign damaged by storm, fire, wind, lightning, earthquake or other natural causes, or negligence of a person to an extent greater than fifty percent (50%) of its depreciated replacement cost shall not be repaired or reestablished.
 - (a) The extent of damage is determined by the cost to repair, rebuild and reestablish the damaged physical components of the sign in conformance with the Building Code as currently adopted by Carson City, so as to make the sign able to display the same sign face as existed before the damage.

- (b) The depreciated replacement cost is determined by the cost (to the same person who would perform the repair and rebuilding using the same materials, labor and equipment as would be used in the repair and rebuilding of the damaged sign) to build and replace the sign new, less depreciation.
 - (c) The costs are limited to the costs of the physical components of the sign and the cost of labor and equipment in performing work on those components.
 - (d) In comparing the costs of damage (subsection (a)(1)(a) of this section) to the depreciated replacement cost (subsection (a)(1)(b) of this section) like materials, like equipment and like labor shall be compared in order to make a valid and consistent comparison. New materials may not be compared to used materials; free or low-cost materials may not be compared to full-price materials, personal labor may not be compared to hired labor; sign owner-supplied labor or equipment may not be compared to contractor-supplied labor or equipment; inconsistent cost comparisons of any kind are not allowed in making the determinations required by this section.
 - (e) If the building official determines that the professional services of an engineer, appraiser, cost estimator, contractor or other appropriate person are necessary to determine the extent of damage and the depreciated replacement cost, he shall notify the owner of the sign who, as a condition of applying for a building permit to perform work on the damaged sign, shall acknowledge the owner's responsibility to pay reasonable fees incurred as a result thereof. No permit of the repair, rebuilding or reestablishment of the sign may be issued until the fees have been paid by the owner.
- b. **Building Permit Exemptions for Nonstructural Work.** Building permits are not required for:
 - (1) Painting or changing of copy on the display surface.
 - (2) Maintenance and repair work involving superficial, essentially nonstructural work such as painting, applying liquid preservatives, replacing light bulbs, tightening and adding fasteners, replacing walking deck, skirting, display panels, border trim on poster panels and similar work that does not involve additions, deletions, reinforcement, replacement, substitution or other changes of structural components that support the display surface of a sign, or which involve a change in materials, design or configuration of the original structural design.
 - (3) Appendages or cut-outs if:
 - (a) The added sign area of the addition is not greater than ten percent (10%) of the area of the maximum display surface set forth in Section 4.8.3(g); and
 - (b) The addition does not extend more than two (2) feet in height above the maximum height limitation set forth in Section 4.8.3(c).
- c. **Building Permits Required for Structural Work.** Building permits are required for any work involving additions, deletions, reinforcement, replacement, substitution or other changes of structural components that support the display surface of a sign, or any work involving a change in materials, or configuration of the original structural design.

4.8.6 Applicability of Other Laws—Severability.

- a. If other chapters of the Development Standards, Title 18, or state or federal laws impose more restrictive requirements on the construction of new signs or on the continuance of existing signs, the more restrictive law shall apply except:
 - (1) Removal of a nonconforming sign is not required if the only nonconformities are the excepted requirements of Section 4.8.3(e); and
 - (2) A more restrictive requirement shall not apply if the requirement violates the prohibitions against giving preferences or greater protection for particular messages, as described in Section 4.8.2, so as to avoid violation of the First Amendment of the Constitution of the United States.
- b. In the event the administrative and other chapters of Title 18 or the Development Standards are invalidated, the procedures and requirements provided for performing work on buildings and structures generally as provided for in other titles, chapters or divisions of this code shall apply to work performed on a sign.
- c. If any provision of this Division is declared by a court of competent jurisdiction to be illegal or unconstitutional, it shall in no way affect the remainder of this chapter or any section thereof, it being intended that the remainder shall remain in full force and effect.

4.8.7 Off-Premises Signs located on City Bus Shelters

- a. Notwithstanding the prohibitions included in Section 4.5, Restricted and/or Prohibited Signs, Subsection 4.5.1, Signs on Trees, Shrubs, Traffic Control Signs, or Utility Poles, which prohibit signs on any structure within the right-of-way, this section authorizes the placement of off-premises advertising signs on authorized Carson City bus shelters located within the right-of-way and on private property.
- b. Off-premise advertising signs on bus shelters shall only be allowed in non-residential zoning districts.
- c. Off-Premise advertising signs shall be prohibited on transit bus shelters in the following areas:
 - (1) Historic District;
 - (2) Residential and Residential Office zoning districts;
 - (3) Within one hundred (100) feet of any residentially zoned property.
- d. Sign Permits may be required for off-premise advertising signs on transit bus shelters.
- e. Off-Premise transit bus shelter advertising signs shall be subject to the Carson City Regional Transportation Commission (RTC) Advertising Policy.
- f. Requirements for Carson City bus shelter signs:
 - (1) The maximum size for an advertising sign is four (4) feet by six (6) feet (twenty-four (24) square feet).
 - (2) Internal sign illumination is prohibited; any external lighting shall be shielded and must be downward.

- (3) No signs resembling any traffic control device, official traffic control sign, or emergency vehicle marking shall be permitted.
- (4) No banners or flying paraphernalia signs shall be permitted.
- (5) No signs that produce sound, noise, smoke or vapor shall be permitted.
- (6) Electronic reader board signs are prohibited, excluding signs that provide information on bus schedules and fares.
- (7) Roof mounted signs are prohibited.
- (8) Sign placement is limited to one (1) side of the bus shelter only.
- (9) Graffiti abatement shall be the responsibility of the RTC.
- (10) Advertising may be permitted on transit bus shelters authorized to be in the public right-of-way as long as the sign does not create a physical or visual hazard to motorists.

SECTION XXXX:

That Title 18 Appendix (CARSON CITY DEVELOPMENT STANDARDS), Division 4 (SIGNS), Section 4.9 (Freeway-oriented sign standards) is hereby amended (**bold, underlined** text is added, [~~stricken~~] text is deleted) as follows:

4.9 Freeway-oriented sign standards.

4.9.1 Purpose. Carson City finds that the limited use of on-premise signs for certain existing and proposed commercial land uses is an appropriate means to help achieve economic sustainability. Carson City also recognizes that there must be a balance between the needs of the business community and the desire of citizens to preserve view corridors along the freeway. To achieve this balance, these guidelines are a means to allow freeway signage that is well designed, appropriately sited, and to the extent possible, esthetically pleasing. These standards are to be utilized in evaluating requests for freeway-oriented signs.

The purpose of these guidelines is to:

- a. Encourage development of property in harmony with the desired character of the city while providing due regard for the public and private interests involved.
- b. Promote the effectiveness of freeway-oriented signs by preventing the over concentration, improper placement, deterioration, and excessive size and number.
- c. Enhance the flow of traffic and the convenience, ease and enjoyment of travel along the freeway.
- d. Protect travelers on Carson City's freeway from injury or damage as a result of distraction or obstruction of vision attributable to large signs.
- e. Assure that public benefits derived from expenditures of public funds for the improvement and beautification of the freeway and other public structures and spaces

shall be protected by exercising reasonable control over the character and design of large sign structures.

- f. Require that signs be properly maintained for safety and visual appearance.

4.9.2 Applicability. The standards contained in this section (4.9) shall apply to all freeway-oriented signs as defined in this chapter.

4.9.3 General Provisions.

- a. A maximum of one freeway-oriented sign may be permitted per parcel or shopping center in addition to other permitted on-premise signs and sign area.
- b. Signs with more than four tenant spaces shall include the shopping center or project name on the sign, which shall be located on the uppermost portion of the sign and shall occupy a minimum of twenty percent of the permitted sign area.

4.9.4 Location and Siting. A freeway-oriented sign may only be located:

- a. On a parcel or shopping center site which has frontage on the freeway right-of-way, and only between the freeway intersection at North Carson Street and 1,500 feet west of the freeway intersection at South Carson Street; and
- b. On a parcel or shopping center site that is either:
 - (1) At least 15 contiguous acres in area; or
 - (2) At least three contiguous acres within 500 feet of a freeway intersection; or
 - (3) At least three contiguous acres located on the corner with frontage on both the freeway and the cross-street; and
- c. On property zoned General Commercial, Retail Commercial or Limited Industrial; and
- d. No more than 200 feet from the right-of-way line of the adjacent freeway; and
- e. A distance of no less than ten times the proposed height of the sign in relation to the ground elevation at the property line of the nearest residentially zoned property, except as otherwise provided in Section 4.9.8.

4.9.5 Design and Construction. A freeway-oriented sign shall be designed and built:

- a. No higher than reasonably necessary in order for the sign copy to be visible from a vehicle approaching on the same side of the freeway as determined by a line-of-site analysis and in no case more than 30 feet above the highest freeway improvement immediately adjacent to the proposed sign, including freeway barriers and soundwalls but excluding light fixtures and sign structures; and
- b. Having a form, texture, color, and finish that incorporates representations complimentary to the primary architectural or natural features of the associated development or feature; and
- c. Having low maintenance, architectural-grade surfacing materials such as metal, masonry, ceramic tile, glass or stucco; and
- d. Having a sign area determined by the lesser of:

- (1) One square foot of sign area for each two lineal feet of freeway right-of-way frontage or one square foot of sign area for each lineal foot of building frontage facing the freeway right-of-way, whichever is greater; or
 - (2) 50 square feet per acre of parcel; or
 - (3) 600 square feet; and
- e. Limiting nighttime illumination to just the sign copy or sign message. Internally illuminated signs shall have opaque backgrounds so that only the sign copy is illuminated. Where a background is integral to the design of a corporate image or registered trademark, the background is to be colored to mute the amount of illumination. Vacant or blank tenant sign panels shall be blocked out.
 - f. To be located appropriately on the site for visibility from the freeway while minimizing the sign height in accordance with this section.
- 4.9.6 Exterior Illumination. A freeway-oriented sign composed of exposed neon, argon or krypton tubing, exposed incandescent lighting, or other exposed artificial lighting to outline such sign or portion thereof, is permitted provided such illumination:
- a. Constitutes a design component of the overall sign architecture; and
 - b. Is integrated into the primary physical elements of sign and is harmonious with the architectural style of the structure; and
 - c. Serves only for the purpose of embellishing the nighttime architecture of the sign and does not portray an advertising message or move, blink or change in intensity; and
 - d. Is compatible with the land use and architecture of adjacent developments; and
 - e. Is fully functional. If any component of the lighting becomes nonfunctional, none of the lighting system may be illuminated until the entire lighting system is repaired and is functioning as intended.
- 4.9.7 Electronic Message Display. A freeway-oriented sign using an electronic message display is permitted provided:
- a. The electronic message display portion of the sign is no more than fifty percent of the total sign area.
 - b. The display contains static messages only with no animation, moving video or change in intensity of lighting; and
 - c. The message change sequence is accomplished immediately or by means of fade or dissolve modes with each frame displayed for a minimum period of four seconds, and shall have no continuous, traveling or scrolling displays or movement, nor shall it have the appearance or illusion of movement of any part of the sign structure, design, pictorial segment of the sign, including the movement of any illumination or the flashing, scintillating or varying of light intensity; and
 - d. The electronic message display has automatic photocell dimming capabilities based on ambient outside light and is set at seventy-five percent of full capacity for daytime (full sun) and forty percent for nighttime, or equivalent for other lighting technologies.

- e. The applicant provides written certification from the sign contractor that the sign's light intensity has been factory pre-set not to exceed the limits specified above, and the intensity level is protected from end-user manipulation by password-protected software or other method as deemed appropriate by the Director.
- f. Notwithstanding other provisions of Title 18, electronic message displays may be required to comply with any future amendments to the limitations on the brightness of the display or reduce the brightness permitted through the special use permit process based upon review of the actual sign in the field for compatibility with the surrounding properties. The Director shall schedule freeway-oriented signs with electronic message displays for review by the Commission within six months of the completion of the sign.

4.9.8 Modifications and Alternatives. The Commission may approve modifications or alternatives to these freeway-oriented sign standards when:

- a. The proposed sign incorporates special design features or unique architectural elements that represent superior quality; and
- b. Such modifications or alternatives are consistent with the intent of these standards and will result in conditions that are commensurate with or superior to these standards; and
- c. One of the following is present:
 - (1) An individualized assessment reveals the existence of extraordinary conditions involving topography, land ownership, adjacent development, parcel configuration, or other factors related to the development site; or
 - (2) The proposed or existing development exhibits unique characteristics of land use, architectural style, site location, physical scale, historical interest or other distinguishing feature that represents a clear variation from conventional development; or
 - (3) Where a reduction in the required setback from residential property is proposed, evidence that the residents within the setback area will be screened from view of the sign by other means such as freeway soundwalls, buildings, or other features.

4.9.9 Permit Requirement. A freeway-oriented sign may only be approved by special use permit.

- a. Exception. A freeway-oriented sign that is no more than 30 feet in overall height and meets all other requirements for freeway-oriented signs may be reviewed and approved administratively through the sign permit process.

4.9.10 Required Submittals with Special Use Permit Application. In addition to site plan(s), elevation(s) and other standard submittals typically required for special use permit applications, the applicant shall submit additional support materials, as follows:

- a. Photographs documenting observation (e.g. field test with crane and balloon). The observation shall document at minimum four possible sign heights (the proposed height plus two lower and one higher than proposed).
 - (1) Each documented option shall differ a minimum of ten feet from the next option.

- (2) Written notice of the test shall be made to the Planning Director ten working days in advance of the test date.
 - (3) The test shall be observed or verified by the Planning Director or his/her designee.
 - (4) Heights shown in the observation shall be confirmed by an independent source: the Planning Director, his/her designee, or by professional survey.
 - (5) The device used to confirm the proposed heights shall have sufficient size and substance so as to provide a comparable sense of scale for the proposed sign. Examples of sufficient size and substance include four foot wide banners strung between two balloons, or four foot by eight foot sheets of plywood suspended in place by a crane.
 - (6) If balloons are used, methods to limit wind drift should be utilized, such as tethering.
- b. Computer photo simulations or other professionally rendered (to scale) perspectives in which the proposed sign is depicted on site, as if the sign were already in place.
 - (1) Simulations or renderings shall depict several vantage points.
 - (2) At minimum, at least one of the photo simulations or renderings shall depict the view or potential view of the sign from the same side of the freeway as the sign placement approximately 1,000 feet from the sign.
 - (3) Photo simulations shall include at least one view from the residential subdivision closest to the overall project site related to the sign.
 - c. A section drawing depicting the line-of-sight available to the occupants of a vehicle approaching the sign from 1,000 feet away.
 - d. If the proposed sign is located with the Airport Review Area as identified by the Planning Division, the applicant shall submit written comments from the Airport Authority regarding FAA and/or Airport Authority requirements for construction of the sign. Freeway-oriented signs shall comply with all applicable FAA requirements.

SECTION XXXX:

That Title 18 Appendix (CARSON CITY DEVELOPMENT STANDARDS), Division 5 (HISTORIC DISTRICT), PREFACE is hereby amended (**bold, underlined** text is added, [~~stricken~~] text is deleted) as follows:

PREFACE

Carson City's historic district is often thought of as a "Victorian Village" frozen in time. Nothing could be further from the truth. Carson City's historic district reflects a unique variety of ongoing economic, social and political circumstances. The district provides a link with Nevada's past through historic buildings dating from the early [~~1860's to the 1950's.~~] **1860s to the 1950s.**

Modest in scale, means and architectural pretense, these buildings document Nevada's development as a state and give Carson City its unique character.

The value of Carson City's historic resources was formally recognized by the Carson City board of supervisors in May 1982 with the creation of the historic district and the designation of an architecture review committee. Renamed the [~~historic resources commission (HRC),~~] **Historic Resources Commission**, it is comprised of property owners, building, design, and preservation professionals. By ordinance, the [~~Carson City historic resources commission~~] **Historic Resources Commission** is charged with maintaining the overall architectural character of the district and properties listed or eligible for the National Register of Historic Places within the guidelines recommended by the U.S. Department of the Interior, National Park Service. Carson City adopted these guidelines to protect and preserve its heritage.

The [~~commission~~] **Historic Resources Commission** recognizes that Carson City's future prosperity lies in a balanced approach to economic development and historic preservation. These objectives are not mutually exclusive. The [~~commission~~] **Historic Resources Commission** realizes that it is necessary to maintain a balance between preservation and utility.

This [~~section~~] **Division** explains the review policies and design guidelines of the [~~commission~~] **Historic Resources Commission** when [~~reviewing~~] **the Commission reviews** projects within the **historic** district, whether [~~involving~~] **the project involves** historic structures or new construction.

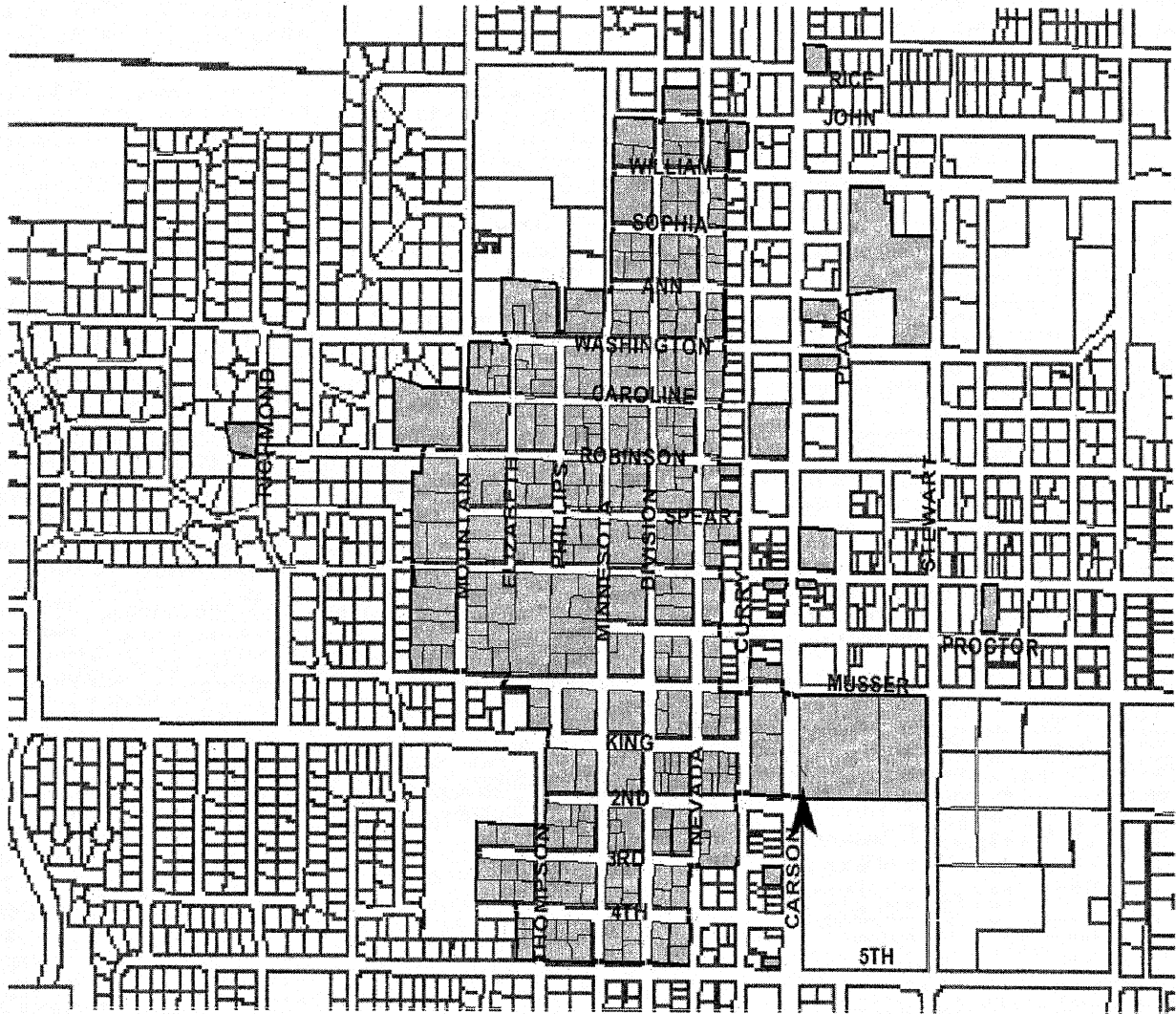

HISTORIC DISTRICT MAP
Carson City, Nevada

SECTION XXXX:

That Title 18 Appendix (CARSON CITY DEVELOPMENT STANDARDS), Division 5 (HISTORIC DISTRICT), Section 5.1 (Introduction) is hereby amended (**bold, underlined** text is added, [~~stricken~~] text is deleted) as follows:

5.1 Introduction.

The architectural styles found in Carson City's historic district span approximately 100 years from the 1860s to the 1960s. Examples of ten architectural styles found in the historic district were selected. Less common styles in the district have not been [~~included, however,~~]; **However,** the buildings representing these styles are equally important to the district's character.

Between the [city's] founding **of the City** in 1858, and 1874, the Greek Revival and Gothic Revival styles were popular. After 1874, four "Victorian" period styles were adopted: the

Italianate, Second Empire, Queen Anne and [~~Stick/Eastlake~~] **Stick or Eastlake** styles. By the turn of the century, changing architectural fashions prompted period revivals and "modern" architecture. The period revivals included: Colonial, Classical, Mediterranean and English Country. The modern styles included the Bungalow Craftsman, a uniquely American creation, and [~~Art Deco/Modern~~] **Art Deco or Modern**. These styles were popular in Carson City up to World War II.

Architectural styles form a system which describes the design of the building - its scale, mass, proportions, height, rhythm and ground plan - and the architectural details - such as roofline, exterior cladding, windows, entrances, ornamentation and interior features. A house of a particular style is not just a random collection of parts; all the design elements work together to form a specific image.

Most buildings do not possess all the characteristics of a particular style. Carson City buildings are vernacular interpretations of architectural styles which include the essential form of the style and selected details. Many houses within the historic district reflect the influence of more than one style. For example, a house which was built in the 1860s may have the form of the Greek Revival style, but the original form was enlarged and embellished in the 1880s with Italianate style ornamentation. Similarly, a house constructed in the 1880s could combine the popular Queen Anne and the [~~Stick/Eastlake~~] **Stick or Eastlake** styles in its design.

The designs of a large number of buildings within the historic district do not fall into a discrete style. These "vernacular" houses provided basic shelter for their occupants and were probably built without much regard for the current architectural fashion. These buildings are important to the ambience of the historic district and provide [~~us~~] **the City** with a balance between the modest and the spectacular. Vernacular houses represent building traditions handed down from one generation to another modified by technology, local building materials and geography. Their basic design and modest details are their identifying features.

The character-defining features of a particular house should be recognized and protected through maintenance and rehabilitation. Features which define a building's style and character also contribute to the overall character of the historic district.

SECTION XXXX:

That Title 18 Appendix (CARSON CITY DEVELOPMENT STANDARDS), Division 5 (HISTORIC DISTRICT), Section 5.2 (Greek Revival (1850 to 1870)) is hereby amended (**bold, underlined** text is added, [~~stricken~~] text is deleted) as follows:

5.2 Greek Revival style (1850 to 1870).

Classically inspired architecture developed as an outgrowth of our country's desire to distance its culture from England after the War of 1812. In architecture, classical Greece and Rome became the new inspiration and Nevada adopted these prototypes in the latter part of this era through the Greek Revival style. During this period Greek temples were regarded as the perfect building forms and the character defining features were applied to American residences.

The typical Carson City, Greek Revival house is rectangular or L-shaped in ground plan, is 1 or 1.5 stories, and has clapboard or shiplap siding. A characteristic feature is the gable roof with the gable facing front to emulate the Greek Temple form. Its ornamentation is classical in its derivation as evidenced by plain, boxed cornices with eave returns, simplified columns and in some case, metopes and tryglyths. Windows are commonly six-over-six light, double hung with cornice molding. The typical entrance in this style includes a paneled door with transom and sidelights. Front porches are common.

There is no dominant floor plan, front facade fenestration pattern, or porch type associated with Greek Revival residences in Carson City. Greek Revival appears to be the most popular pre-Victorian period style for residential construction. Many houses in the vernacular of the Greek Revival style include ornamentation from the Italianate style.



Built in 1862 by a Carson City carpenter named Smaill, this house, at 512 North Curry Street, is one of the finest Greek Revival styled houses in Carson City. Its ornamentation is Classical Greek and suggests a designer familiar with Classical architecture. Its frieze with tryglyths and metopes is unique in Carson City. Its basic form and detailing is typical of the Greek Revival style. Other Carson City examples of Greek Revival include 304 West 5th Street, 108 North Minnesota Street and 406 North Mountain Street.

5.2.1 Characteristic Elements of the Greek Revival Style.

PLAN VIEW:	EXTERIOR SIDING:	WINDOWS:	ORNAMENTATION:
rectangular or L-shaped	horizontal clapboards	double hung sash windows six-over-six lights	Classical: frieze board, dentils, eave returns

HEIGHT:	ROOF:	ENTRANCE:	
one, one and one-half or two story	medium pitched gable roof, eave returns, gable facing front	sidelights and transom around door	

SECTION XXXX:

That Title 18 Appendix (CARSON CITY DEVELOPMENT STANDARDS), Division 5 (HISTORIC DISTRICT), Section 5.3 (Gothic Revival (1850 to 1875)) is hereby amended (**bold, underlined** text is added, [~~stricken~~] text is deleted) as follows:

5.3 Gothic Revival style (1850 to 1875).

Inspired by the romantic movement of the late 18th and early ~~[19]~~ **19th** centuries, the Gothic Revival style came to America from England. Proponents proclaimed the superiority of the Christian medieval past and sought to replace the formal, pagan Greek and Roman architectural styles.

Made popular by the designs of architect Alexander Jackson Davis through the pattern books of landscaper and writer Andrew Jackson Downing, the Gothic Revival style was seen as appropriate for the rural American landscape.

The Gothic Revival style, introduced to Nevada in the 1850s, was popular through the 1870s for residential design and until the early 20th century for church design. [4] **Four** of Carson City's churches built during this period include elements of the Gothic Revival style: First Presbyterian Church (1862-64), First United Methodist Church (1865), St. Peter's Episcopal Church [~~(1867-68),~~] **(1867-68)** and St. Teresa of Avila Catholic Church (1870-71). All 4 churches have Gothic or pointed arch windows: some very plain, some elaborate with tracery and stained glass.

The Gothic Revival style is distinguished by the pointed arch [~~used~~] **which is used** with **features such as** doors, [~~windows, entries, etc.~~] **windows and entries**, and its elaborate woodwork. The invention of the jigsaw allowed builders to produce an endless variety of fancy wooden details—"gingerbread"—cheaply and quickly. These wooden decorative embellishments are found on Gothic Revival style buildings in the form of bargeboards, pendants, finials, [~~brackets,~~] **brackets** and other ornamentation.



The J.D. Roberts house, built in Washoe City in 1859 and moved to its present location at 1206 North Carson Street in 1873, is Carson City's finest residential example of the Gothic Revival style. Note the following characteristic elements of Gothic Revival: steeply pitched, cross gabled roof; bargeboard decorating the gable [~~ends:~~] **ends**; and pointed arch or "Gothic" windows. Another domestic Gothic Revival style building in Carson City is the Ormsby-Rosser house at 304 South Minnesota Street.

5.3.1 Characteristic Elements of the Style.

PLAN VIEW:	EXTERIOR SIDING:	WINDOWS:	ORNAMENTATION:
rectangular, L-shaped, or T-shaped	clapboard vertical board-and-battens	pointed arched or Gothic commonly located in the gable end	jigsaw-cut bargeboards, brackets, balustrades, porch, frieze

HEIGHT:	ROOF:	ENTRANCE:	
one and one-half story, one story porch	steeply pitched cross gables	pointed arch door, sidelights and transom	

SECTION XXXX:

That Title 18 Appendix (CARSON CITY DEVELOPMENT STANDARDS), Division 5 (HISTORIC DISTRICT), Section 5.4 (Italianate (1875 to 1900)) is hereby amended (**bold, underlined** text is added, [~~stricken~~] text is deleted) as follows:

5.4 Italianate style (1875 to 1900).

The Italianate style was derived from the rural architecture of northern Italy and came to the United States via England as part of the Picturesque movement. The Picturesque movement was a reaction to the earlier classically influenced styles and includes both the Gothic Revival and the Italianate architectural styles. Introduced into the United States during the 1830s, the Italianate style dominated American domestic architecture between 1850 and 1880. Its popularity was spread by the pattern books of landscaper and writer Andrew Jackson Downing, who utilized the designs of architect Alexander Jackson Davis.

Italianate style buildings are identified by heavy, wooden cornices, window surrounds and door overhangs. Window bays, [~~cupolas,~~] **cupolas** and entry hoods also are typical of the style. Roofs are typically low, hipped or gabled and finished with a boxed cornice. Windows are tall and narrow.

Carson City has several Italianate styled houses. Many houses designed from the 1870s and 1880s combine some Italianate style influences along with other styles. Earlier houses also include Italianate style features, probably resulting from remodeling in the late 1870s or 1880s. A larger number of Italianate residences survive in Virginia City.



The Lou Meder house located at 308 North Nevada Street was built circa 1875 and is an excellent example of the Italianate style in Carson City. The house has the typical heavy boxed cornice with double brackets and dentils; a paneled entry with recessed door under a hood; and characteristic square window bays. This house is 1 story while most houses in this style are 2 or 3 stories adding to the vertical emphasis. Another Italianate example is the Rinckel Mansion at 102 North Curry Street.

5.4.1 Characteristic Elements of the Style.

PLAN VIEW:	EXTERIOR SIDING:	WINDOWS:	ORNAMENTATION:
rectangular	shiplap	tall narrow sometimes arched one-over-one light with heavy and elaborate crowns	boxed cornice with brackets, bay windows cupolas, entry hoods

HEIGHT:	ROOF:	ENTRANCE:	
two stories or more	low pitched, hipped or gabled roof	tall door with transom recessed door paneled entry	

SECTION XXXX:

That Title 18 Appendix (CARSON CITY DEVELOPMENT STANDARDS), Division 5 (HISTORIC DISTRICT), Section 5.5 (Second Empire (1860 to 1880)) is hereby amended (**bold, underlined** text is added, [~~stricken~~] text is deleted) as follows:

5.5 Second Empire style (1860 to 1880).

The Second Empire style originated in France and took its name from the reign of Napoleon III (1852-1870). Considered a "modern" style, its most identifying feature is the mansard or dual-pitched hipped roof introduced by 17th century French architect Francois Mansart. The boxy roofline allows a full story of usable attic space.

This style is characterized by: a mansard roof; roof dormers; decorative patterns of color or texture in the roofing material—often wooden shingles of different cuts; and a tower with a curved roofline. Below the roof, Second Empire styled houses may borrow many of the characteristics of the Italianate style including: heavy wooden cornices, window surrounds and door overhangs; tall and narrow windows, window bays, cupolas and entry hoods.

The Second Empire style was popular in the United States between 1860 and 1880. Used for many public buildings during President Grant's administration (1869-77), it is sometimes referred to as the General Grant style. The Second Empire style was not widely used in the west and rapidly declined in popularity following the panic of 1873. Nevada's most prominent Second Empire public building is the Fourth Ward School (1876) in Virginia City.



The Beck-Barber-Belknap house, 1206 North Nevada Street, is [1 of 3] **one of three** extant Second Empire styled houses in Carson City. Built in 1875 by H.H. Beck, the house was later owned from 1881 to 1908 by Supreme Court Justice Charles Belknap. The Second Empire styled house has the characteristic mansard roof with arched hooded dormers. Eave lines are decorated with brackets and dentils. A full front width porch and square window bays further enhance the design. The [2] **two** other examples of the Second Empire style in Carson City are 1112 North Carson Street and 503 East Telegraph Street.

5.5.1 Characteristic Elements of the Style.

PLAN VIEW:	EXTERIOR SIDING:	WINDOWS:	ORNAMENTATION:
rectangular	shiplap	tall narrow sometimes arched one-over-one light with heavy and elaborate crowns	boxed cornice with brackets, bay windows cupolas, entry hoods

HEIGHT:	ROOF:	ENTRANCE:	
two stories or more	mansard with dormers dormers often patterned wood shingle	tall door with transom recessed door paneled entry	

SECTION XXXX:

That Title 18 Appendix (CARSON CITY DEVELOPMENT STANDARDS), Division 5 (HISTORIC DISTRICT), Section 5.6 (Stick (1875 to 1895)) is hereby amended (**bold, underlined** text is added, [~~stricken~~] text is deleted) as follows:

5.6 Stick style (1875 to 1895).

The Stick style was promoted through period pattern books along with the Italianate and Second Empire styles but never gained the popularity of the other styles. Stick style architecture is defined by decorative stickwork applied to the wall planes rather than applied to **features such as** windows, [~~doors, cornices, etc.~~] **doors and cornices.** The Stick style was used to express the

structure of the building through its ornamentation on the exterior walls. Wall ornamentation imitated corner posts, studs, brackets, bracing and other structural elements. A typical Stick style house would include some of the following features: steeply pitched, gabled or cross-gabled roof; decorative trusses at the gables; overhanging eaves supported by simple brackets; horizontal board siding with stickwork decoration - patterns of horizontal, vertical or diagonal boards raised from the wall surface; and porches with diagonal braces.



112 North Curry Street is a Carson City example of the Stick style. Although not a strict Stick style design, this building has a tall corner tower decorated with diagonal Stickwork ornamentation and diagonal braces decorating the front porch.

SECTION XXXX:

That Title 18 Appendix (CARSON CITY DEVELOPMENT STANDARDS), Division 5 (HISTORIC DISTRICT), Section 5.7 (Queen Anne (1880 to 1905)) is hereby amended (**bold, underlined** text is added, [~~stricken~~] text is deleted) as follows:

5.7 Queen Anne style (1880 to 1905).

The Queen Anne style has little to do with England's Queen Anne or the style of formal Renaissance architecture popular during her reign in the 18th century. The style was named and popularized in England by a group of architects led by Richard Norman Shaw. The most popular domestic style of architecture during the last [2] **two** decades of the 19th century, the Queen Anne is conspicuously eclectic and romantic. It is decoratively rich with bright colors and a generous variety of exterior wall textures. The Queen Anne house is typically asymmetrical and large with multi-gabled roofs and tall, decorated chimneys. Towers with conical roofs and turrets protrude from corners. The style frequently uses: a multiplicity of window types including rectangular, oval, [~~round,~~] **round and** square; slanted and square bays; and oriels. [~~Wrap-around~~] **Wraparound** veranda and porches with turned posts are typical of the Queen Anne style.

There are many variations of the Queen Anne style in the United States. Some are based on different roof types and others are based on various types of ornamentation. Throughout the

United States, about half of the Queen Anne houses are ornamented with spindlework. Spindlework, delicately turned wooden pieces, were used as porch balustrades, porch friezes and in gables. About [$\frac{1}{3}$] **one-third** of the Queen Anne houses in this country used Classical ornamentation. Classical columns replaced posts with spindlework: Palladian windows, cornice line-dentils and other classical details were also employed. [2] **Two** other expressions of the Queen Anne style not typical to Carson City include half-timbered work and patterned masonry.

Related to the Queen Anne style is the Princess Anne style: a slightly later and subdued derivative of the popular Queen Anne style. Princess Anne style houses retain the asymmetrical plan and mass, multiple gables, and tall, decorated chimneys. In keeping with the 20th century move towards more restrained decoration, the Princess Anne style is less ornamented and does not include the characteristic towers, [turrets,] **turrets** and verandahs of its progenitor.

The Queen Anne Cottage style is derived from the Queen Anne style. This smaller version [(usually 1 or 1.5 stories)] , **usually 1 or 1.5 stories**, first appeared in the 1880s and was ideally suited for smaller city lots. It retains the asymmetrical massing of the large Queen Anne and is dominated by a tall gabled roof. Ornamentation is usually confined to the gable end. Typically, a front window bay, corner porch and a variety of window types are included.

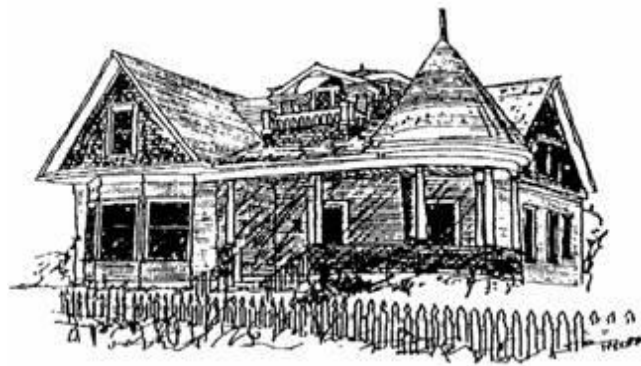

The Springmeyer House located at 302 North Minnesota Street is a rare Carson City example of the Queen Anne style. Built in 1908 by H. H. Springmeyer, a member of the Douglas County ranching family, the house is also known as the home of Governor and Mrs. Charles Russell. Typical of the Queen Anne style, this house has both clapboard and shingle siding; gabled, hipped, and conical roof forms; asymmetrical massing; a roof dormer with balcony; and a slanted bay.

5.7.1 Characteristic Elements of the Style.

PLAN VIEW: irregular	EXTERIOR SIDING: shiplap, clapboard fancy cut shingles for second floor or gable end	WINDOWS: many types and shapes	ORNAMENTATION: spindlework: turned balustrade, frieze turned posts, Classical columns, dentils, Palladian windows
-------------------------	---	-----------------------------------	--

HEIGHT:	ROOF:	ENTRANCE:	
---------	-------	-----------	--

two stories or more	hipped or gabled or combination, conical roof over tower/turret	Classical or ornate single or double doors often a single light	
---------------------	---	---	--

SECTION XXXX:

That Title 18 Appendix (CARSON CITY DEVELOPMENT STANDARDS), Division 5 (HISTORIC DISTRICT), Section 5.8 (Colonial & Classical Revival (1895 to 1915)) is hereby amended (**bold, underlined** text is added, [~~stricken~~] text is deleted) as follows:

5.8 Colonial [~~&~~] and Classical Revival styles (1895 to 1915).

At the end of the ornate Victorian period, American builders sought new inspiration for 20th century residential design. As suburban living became the norm for an increasing number of Americans, earlier and more rural building forms and styles from both the United States and Europe were chosen as prototypes. [2] **Two** stylistic movements grew in the early 20th century: the "Picturesque" Period Revival and the Modern movement.

The World's Columbian Exposition held in 1893 in Chicago was built with a classical theme and started this architectural revival in classical forms. Colonial and Classical Revival styles were dominant for residential building in many parts of the country in the first part of the 20th century, but few Classical and Colonial Revival houses were built in Carson City.

The Colonial Revival style is a restrained, dignified, [~~and~~] harmonious [~~style, uniquely American, based Colonial styles~~] **and uniquely American-based Colonial style** [~~which, in turn, were~~] **which was** influenced by Classical Roman designs. The typical Colonial Revival style design is a large, two storied, rectangular-in-plan structure with a paucity of exterior projections from its symmetrical facade. A centrally placed entrance is the major focus of the design. The door is commonly framed by sidelights and topped with a fanlight. A portico may cover the entrance. Windows are double hung; Palladian windows are a popular feature. The hipped roof is moderately pitched and includes a projecting cornice ornamented with modillions and dentils. Classical, fluted pilasters, quoins or cornerboards ornament the corners.

The identifying feature of the Classical Revival [~~include:~~] **style includes:** a dominating full-height porch with roof support by classical columns; columns with Ionic or Corinthian capitals; central door; and symmetrical facade.

The most prominent Classical Revival style house in Carson City is the Governor's Mansion at 600 North Mountain Street. Built in 1909 as the Governor's Mansion, the large symmetrical building is ornamented with a pedimented front porch supported with fluted columns with Ionic capitals; a projecting cornice with modillions; and classically inspired door and window moldings.



Pictured above is a fine Carson City example of the Colonial Revival style. Built in 1915, the Ira I. Winters house at 600 North Richmond Avenue is sometimes called a Classic Box; the house is a 2-story, rectangular-in-plan box topped with a hipped roof. The front dormer, the [1-story] **1-story** full width porch, and the quoins are all typical to the Colonial [~~Revival.~~] **Revival style.**

SECTION XXXX:

That Title 18 Appendix (CARSON CITY DEVELOPMENT STANDARDS), Division 5 (HISTORIC DISTRICT), Section 5.9 (Bungalow/Craftsman (circa 1905 to 1930)) is hereby amended (**bold, underlined** text is added, [~~stricken~~] text is deleted) as follows:

5.9 [Bungalow/Craftsman] Bungalow or Craftsman style (circa 1905 to 1930).

Moving toward a modern lifestyle, the architects that popularized the Craftsman and Bungalow styles were among the first to emphasize comfort and convenience, concepts of human scale and sensible plans. Their designs helped shape a growing phenomenon of the time: the affordable small house for the middle class. The designs (in wood or brick) provided an easy to build, affordable house for the growing middle-class, who were moving to the suburban fringe of cities. The homes were also the first to include a detached garage.

The Craftsman style represented an independent western movement in American architecture. Its guiding force was the English Arts and Crafts movement, which rejected the mass reproduction and mediocre design associated with the Industrial Revolution in favor of the beauty and "honesty" of traditional handcraftsmanship and natural materials. The Craftsman ideas were widely disseminated in the pages of the Craftsman magazine, published from 1901 to 1916 by the furniture maker and designer Gustave Stickley. The style was adapted for countless small houses and bungalows but found its most sophisticated expression in the work of Pasadena architects Greene and Greene. Craftsman details often included inglenooks, built-in wood cabinets, wood beam ceilings and large fireplaces.

The Bungalow is often affiliated with the Craftsman but also may be influenced by Japanese, chalet and period styles. The Bungalow is typically a snug 1.5 story home with wide

overhanging roof, deep porch and simple interior with built-in cupboards. The interior floor plan differs little from prior architectural styles with floor plans divided into small distinct rooms. 1 exception was the inclusion of a plumbed bathroom. Other conveniences such as central heating, electricity and gas ranges were becoming standard during this period.



The Craftsman Bungalow was the dominant residential building style in the United States between 1905 and 1920. The house at 202 North Curry Street, illustrated above, is a typical example. Note the exposed rafter ends, the purlins decorating the gable end, the 3 part windows with four-lights-over-one-light and the typical front porch with typical elephantine posts on piers. Also, 502 West Spear Street is an excellent example of a brick Bungalow and is similar to the brick Bungalows prevalent in southwest Reno. Few examples of the style survive in Carson City.

5.9.1 Characteristic Elements of the Style.

PLAN VIEW:	EXTERIOR SIDING:	WINDOWS:	ORNAMENTATION:
rectangular, square L-shaped masonry	wood shiplap, shingles	grouped in pairs or ribbons multi-pane over single, double-hung or fixed sash, decorative pane glass	stick work, dormers, extended rafter ends, eave braces and brackets, window boxes, balconies, bay windows, stone or large masonry exterior chimney, Oriental or flared roof line, exposed beams

HEIGHT:	ROOF:	ENTRANCE:	SPECIAL FEATURES
one or one and one-half story	low pitch, wide overhang eaves, hipped, front gable, cross-gable, side-gable	raised entry porches, porch columns or piers baustrades	detached garage often in the same style as the house

SECTION XXXX:

That Title 18 Appendix (CARSON CITY DEVELOPMENT STANDARDS), Division 5 (HISTORIC DISTRICT), Section 5.10 (Period Revival (1900 to 1940)) is hereby amended (**bold, underlined** text is added, [~~stricken~~] text is deleted) as follows:

5.10 Period Revival (1900 to 1940).

In an era of major social and cultural change, Period Revival houses were designed to conjure up the romantic times and far away places of another "period" in history. Popular styles from the past include the English Cottage, Tudor Revival, Dutch Colonial, Country Cottage, Mediterranean Revival and Spanish Colonial. There are "high-style" examples which include all the major elements of a particular style, and vernacular examples which may incorporate only one or two elements into the design. Modest examples of the English Cottage and the Mediterranean styles are found in Carson City's historic district.

5.10.1 English Cottage Revival. The English Cottage style is the most modest of the English Revivals, which were popular in America between 1910 and 1930. The prototype of the English Cottage is the masonry rural farmhouse of England. This quaint and charming, typically 1 story cottage is usually constructed of stone, stucco or brick construction. Distinguishing features include an asymmetrical composition, a steeply pitched roof with little overhang and a steeply pitched front entrance. Large expanses of wall are pierced by relatively few windows.

5.10.2 Mediterranean Revival. The key to distinguishing the Mediterranean Revival style is its heavy tile roof and restrained ornamentation. The structures are generally wood frame construction with a smooth or textured stucco wall surface painted white or a light color. Ornamentation is restrained; wall surfaces are flat with few projections. Windows are casements and framed by wooden or wrought iron grills. Small, second story balconies are typical. The Mediterranean Revival style was used for public, commercial and residential structures.



500 West Telegraph Street, built in 1926, is an example of the Mediterranean Revival style of domestic architecture. Although remodeled, the residence maintains key stylistic features of the style: a heavy red tile roof, a corner tower with hipped roof, white stucco walls and round arched openings. An example of the English Cottage style is 1008 North Curry Street.

SECTION XXXX:

That Title 18 Appendix (CARSON CITY DEVELOPMENT STANDARDS), Division 5 (HISTORIC DISTRICT), Section 5.11 (Ranch Style (1940 to 1960)) is hereby amended (**bold, underlined** text is added, [~~stricken~~] text is deleted) as follows:

5.11 Ranch Style (1940 to 1960).

The Ranch house was perhaps the ultimate symbol of the postwar American dream: a safe, affordable home promising efficiency and elegant, casual living inspired by California's temperate climate. California architects, such as Cliff May introduced the "A close-to-the-ground" ranch in the 1930s, evidently finding inspiration in the 1-story plan of the Spanish rancho of the Southwest. By the late 1940s, this new house type had caught on across the country and still remains popular. After World War II, the popularity of the Ranch house increased, especially with dependence on the automobile and newly constructed suburban neighborhoods. In the West, where land was available, the new large lots provided plenty of room for a rambling, 1-story plan, driveway, garage and expanse of green lawn.

The classic Ranch is a rectangular or L-shaped house whose low-pitched roof caps an open, free-flowing plan. The house is typically long, narrow, and low to the ground, with a strong emphasis on the horizontal. The roof is usually hipped with wide overhanging eaves. The Ranch style also features wide porches, large patios or interior courtyards, a de-emphasis of the main entrance, integral garage, large windows, and use of native materials, especially masonry as accents. The use of large glass windows or glass walls suggests the connection to the outside.

The interior of the Ranch house also differs dramatically from earlier styles by diminishing the boundaries between formal and informal spaces. Ranch houses might still have a formal living room based on the parlor concept, but more often the dining room was situated between the kitchen and the new "family" room. With its open kitchen/living area, the ranch was specifically geared to casual entertaining. Another key point was the desirable indoor/outdoor living promised by the one-story layout, which features sliding glass doors, picture windows, terraces and patios secluded in a rear yard.

- 5.11.1 Minimal Traditional (1935 to 1950). With the economic Depression of the 1930s came this compromise style which reflects the form of traditional Eclectic houses, but lacks their decorative detailing. Roof pitches are low or intermediate and eaves and rake close, rather than overhanging. Usually, but not always, the design incorporates a large chimney and at least 1 front-facing gable. Many examples suggest Tudor cottages with the roof line lowered and detailing removed. These houses were built in great numbers in the years immediately preceding and following World War II.



A modest example of a period revival home on West Robinson St.

5.11.2 Ranch (1940 to 1975). Asymmetrical 1-story shapes with low-pitched roofs in one of 3 forms: hipped (the most common), cross-gabled and side-gabled. There is usually a moderate or wide eave overhang. This may be either boxed or open, with the rafters exposed as in Craftsman houses. Both wooden and brick wall cladding are used, sometimes in combination. Builders frequently add modest bits of traditional detailing, usually loosely based on Spanish or English Colonial precedents, such as decorative iron or wooden porch supports and shutters. Ribbon windows are frequent as are large picture windows in living areas. These private outdoor living areas to the rear of the house are a direct contrast to the large front and side porches of most late 19th and early 20th century styles.



A typical Ranch style home in Carson City. This is located on King Street at the periphery of the historic district.

5.11.3 Split Level (1955 to 1975). The style rose to popularity during the 1950s as a multi-story modification of the then dominant 1-story Ranch house. It retained the horizontal lines, low-pitched roof and overhanging eaves of the Ranch house, but added a 2-story unit intercepted at mid-height by a 1-story wing to make 3 floor levels of interior space. An elaborate theory of interior planning grew around this form. Families were felt to need 3 types of interior spaces: quiet living areas, noisy living and service areas, and a sleeping area. The Split Level form made it possible to locate these on separate levels. The lower level usually housed the garage and, commonly, the "noisy" family room with its television, which was becoming a universal possession. The mid-level wing contained the "quiet" living areas and the upper level the bedrooms.

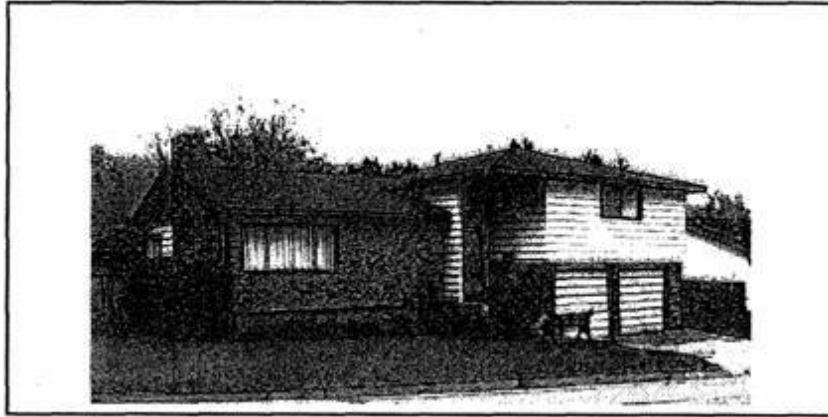

1 of several examples of a split-level home in Carson City. This is located on Westview at the periphery of the historic district.

5.11.4 Variations of the Ranch Style in Carson City.

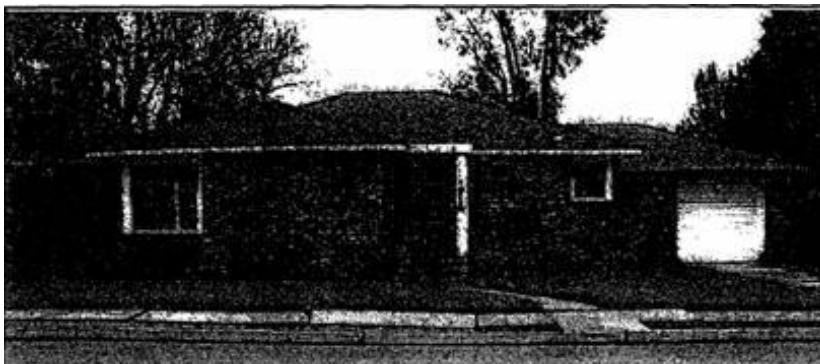
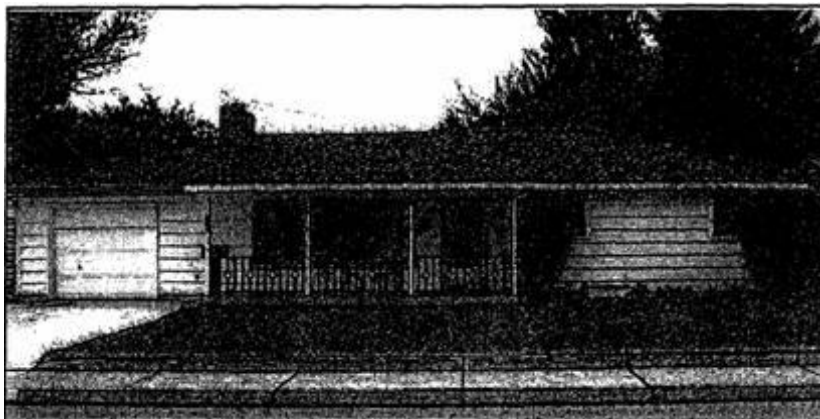

Characteristic Elements of the Ranch Style.

PLAN VIEW:	EXTERIOR SIDING:	WINDOWS:	ORNAMENTATION:
rectangular, L-shaped, U-shaped	rustic drop, vertical board and batten, masonry veneer or in combination	large picture windows, single pane, double-hung sash, slider, jalousie, sliding patio	very limited but may include shutters, masonry walls, planters, Tudor or Colonial details

HEIGHT:	ROOF:	ENTRANCE:	SPECIAL FEATURES
one story, split level rarely one and one-half story	low pitch, wide overhang eaves, hipped, front gable, cross-gable, side-gable	de-emphasized, undecorated, often focus is on the rear of the house	integrated garages, patios, covered walkways, interior courtyards

SECTION XXXX:

That Title 18 Appendix (CARSON CITY DEVELOPMENT STANDARDS), Division 5 (HISTORIC DISTRICT), Section 5.12 (Glossary) is hereby amended (**bold, underlined** text is added, [~~stricken~~] text is deleted) as follows:

5.12 Glossary.

"Balloon frame" means a timber frame construction having uprights (studs) that extend in 1 piece from foundation line to the roof with horizontal members (joists) nailed to them.

"Baluster" means an upright support for the stair railing or banister.

"Balustrade" means a railing consisting of a handrail on balusters.

"Bargeboard" (verge board) means a stylized rafter set out from a gable, usually pierced with jig-sawn design. Used especially on Gothic Revival houses.

"Bay" means a structural set, composed of columns and beams or piers and vaults; it is one of a group of such sets. Each added unit makes another bay. A projection from an exterior wall which rests on its foundation and creates space within.

"Belt course" means a band or strip of building material or molding such as bricks, wood, or stone around a building, or along the length of the facade.

"Billboards" mean outdoor advertising signs containing a message, commercial or otherwise, which is unrelated to the merchandise for sale or services performed by the person or business on whose property the sign is located, posted for a fee by the owner of the sign framework.

"Board-and-batten" means vertical siding composed of wide boards that do not overlap and narrow strips (battens) nailed over the spaces between the boards.

"Bracket" means a structural support attached to a wall and bolted to or bearing thereon. Often used as decorative feature connecting an overhanging cornice to the frieze board. Consoles and modillions are brackets in Classical architecture.

"Capital" means the crowning element of a column, pilaster or pier.

"Casement windows" means a window which opens inward or outward from hinges to the side of the frame.

"Clapboard" means a narrow board thicker on one edge to facilitate overlapping; applied horizontally to form a weatherproof, exterior wall surface.

"Column" means an architectural support of definite proportions, usually cylindrical in shape, with shaft, capital and sometimes, a base. May be free-standing or attached to a wall. See pilaster.

"Cornice" means (1) the topmost part of the entablature in classical architecture; (2) any projecting horizontal molding which crowns an exterior elevation, sometimes a window or door; or a molding used internally at the junction of wall and ceiling.

"Cresting" means an ornamental decoration along the ridge of a building often of wood or iron work.

"Cupola" means a small dome and the shaft that supports it, sits on top of the building.

"Dentils" means a small square block used in a series for ornamentation in Ionic and Corinthian cornices. A dentil course is a series of dentils.

"Dormer" means a shed, single gable or single hipped roofed structure rising from a slope of the roof; usually pierced by a window.

"Double-hung window" means a two-part window with an outside sash that slides down and an inside one that goes up. The movement of the sash is usually controlled by chains or cords on pulleys with a sash weight.

"Double-faced sign" means any sign designed to be viewed from 2 directions and on which 2 faces of the sign are either parallel or the angle between them is 30 degrees or less.

"Eave returns" means continuation of the cornice part way across a gable.

"Eaves" means the lower edge of a sloping or gable roof: the line of the rafters beyond the supporting wall.

"Elephantine posts" means tapered (smaller at the top) posts, typically used as a supporting porch member on a Bungalow style residence.

"Entablature" in classical architecture, the elaborated beam member carried by the columns, horizontally divided into architrave (below), frieze and cornice (above). The proportion and detailing are different for each other and strictly prescribed.

"Facade" means the front or face of a building; the entire aspect of the side of the building.

"Fanlight" means radiating panes within a semicircular glazed opening, usually over an entrance.

"Finial" means the carved or molded ornament crowning a gable, gatepost, pinnacle, spire or other roof point.

"Frieze" means the middle division of an entablature, sometimes decorated with sculptural relief. A board parallel and butting a cornice.

"Gable" means the triangular upper portion of an end wall under a peaked roof.

"Gabled roof" means a roof which slopes from both sides of a ridge.

"Gambrel roof" means a double pitched gabled roof.

"Gothic window" means a window topped with a pointed arch.

"Hipped roof" means a roof with slopes on all four sides, continuous from peak to eaves.

"Lights" means the panes of glass in a window. Double-hung windows are designated by the number of lights in the upper and lower sash.

"Lintel" means a horizontal structural beam resting on 2 separate posts, often bridging an opening such as a door or window.

"Mansard roof" means a steep, dual pitched hipped roof allowing a tall attic space; frequently used to add an upper story.

"Modillion" means an ornamental, horizontal, block or bracket under a projecting cornice.

"Oculus" means a round or oval window without tracery or muntins.

"Oriel" means a unit projecting from a wall and carried on brackets, corbels or a cantilever. Unlike a bay, the projection of an oriel does not extend to the foundation.

"Palladian window" means a three-part window with a central, top arched portion and rectangular windows on both sides.

"Pediment" means the triangular space in the gable of a ridged roof or any similar area above porticoes, doors, windows, etc.

"Pendent" means a hanging ornament on eaves, ceilings, and soffits often at the end of a gable roof.

"Pilaster" means a rectangular column or shallow engaged pier projecting only slightly from a wall; in Classical architecture it follows the height and width of a related column, with similar base and capital.

"Pitch" means the amount of slope of the roof in terms of angle or other numerical measure; 1 unit of horizontal rise for 3 units of horizontal shelter is expressed as 1 in 3.

"Porch" means a roofed space outside the main walls of the building; a covered entrance for a building, having a projecting roof supported by columns, posts, or enclosing walls. See recessed porch.

"Quoins" means units of stone, brick or wooden block that are used decoratively to accent the corners of a building. Derived from the French coin or coign (corner).

"Sash" means the framework of stiles and rails in which the panes or lights of a window are set.

"Segmented arched opening" means a slightly curved arch shape, flatter than a semi-circular arch shape, but not flat.

"Shed Roof" means a single plane sloping roof.

"Shiplap" means a beveled jointing of 2 boards to form a weather-resisting outside wall surface.

"Sidelight" means a window flanking a door, usually placed on each side, occasionally found on 1 side of the door. It is frequently narrow and may be the same height as the door.

"Sill" means the bottom member of a window or door frame. The mating of a foundation with the above structure.

"Spindles" means round turned balusters.

"Tracery" means delicate intersecting lines of muntins or glazing bars that form ornamental designs in a window.

"Transom" means a small window over a door or window usually hinged or pivoted, used for ventilation and decoration.

"Verandah" means a roofed, open gallery or balcony extending along the outside of a building and which is designed for outdoor living in hot weather.

SECTION XXXX:

That Title 18 Appendix (CARSON CITY DEVELOPMENT STANDARDS), Division 5 (HISTORIC DISTRICT), Section 5.13 (Secretary of interior standards for rehabilitation) is hereby amended (**bold, underlined** text is added, [~~stricken~~] text is deleted) as follows:

5.13 Secretary of interior standards for rehabilitation.

Rehabilitation is defined as the process of returning a property to a state of utility, through repair or alteration, which makes possible an efficient contemporary use while preserving those portions and features of the property which are significant to its historic, architectural and cultural values.

The standards for rehabilitation are as follows:

1. A property will be used as it was historically or be given a new use that requires minimal change to its distinctive materials, features, spaces and spatial relationships.
2. The historic character of a property will be retained and preserved. The removal of distinctive materials or alteration of features, spaces, and spatial relationships that characterize a property will be avoided.
3. Each property will be recognized as a physical record of its time, place and use. Changes that create a false sense of historical development, such as adding conjectural features or elements from other historic properties, will not be undertaken.
4. Changes to a property that have acquired historic significance in their own right will be retained and preserved.

5. Distinctive materials, features, finishes and construction techniques or examples of craftsmanship that characterize a property will be preserved.
6. Deteriorated historic features will be repaired rather than replaced. Where the severity of deterioration requires replacement of a distinctive feature, the new feature will match the old in design, color, texture, and where possible, materials. Replacement of missing features will be substantiated by documentary and physical evidence.
7. Chemical or physical treatments, if appropriate, will be undertaken using the gentlest means possible. Treatments that cause damage to historic materials will not be used.
8. Archeological resources will be protected and preserved in place. If such resources must be disturbed, mitigation measures will be undertaken.
9. New additions, exterior alterations, or related new construction will not destroy historic materials, features and spatial relationships that characterize the property. The new work will be differentiated from the old and will be compatible with the historic materials, features, size, scale, proportion, and massing to protect the integrity of the property and its environment.
10. New additions and adjacent or related new construction will be undertaken in such a manner that, if removed in the future, the essential form and integrity of the historic property and its environment would be unimpaired.

SECTION XXXX:

That Title 18 Appendix (CARSON CITY DEVELOPMENT STANDARDS), Division 5 (HISTORIC DISTRICT), Section 5.14 (Guidelines for roofs) is hereby amended (**bold, underlined** text is added, [~~stricken~~] text is deleted) as follows:

5.14 Guidelines for roofs.

The roof's shape, the roofing material and its special features are extremely important in defining the building's overall architectural style. Many different historic roof shapes are found in the district: gable, hip, gambrel, mansard, shed and flat. The pitch or slope of the roof changes from style to style. Shed roofs were used extensively for additions to buildings. The type and style of roof features also change with the building style. Brick and stone chimneys, cresting and a variety of dormers are also found in the district. Sawn or milled wood shingles of cedar or redwood are the predominate historic roofing materials within the district. Few tile and no slate roofs have been found. Standing seam or corrugated metal were used on outbuildings.

- 5.14.1 Guidelines for Historic Buildings. Original roofing material and features are to be retained and repaired if at all possible. If new roofing is necessary or desired, the preferred treatment is to replace the original with identical new material. If this is not possible or desirable, then the use of Fireclass A, organic felt or fiberglass matt composition type shingle, preferably in a "thick butt" design is acceptable. These are to be laid approximately five inches to the weather with straight and true exposed edge lines. Other roof features such as chimneys, dormers and/or decorative elements are to

be retained. New mechanical systems, solar panels, skylights and/or other devices on the roof are to be placed so they are inconspicuous from the Street and in such a manner that no damage is done to any character defining features of the building. (Secretary of the Interior's Standards for Rehabilitation (Standard Number: 2, 6))

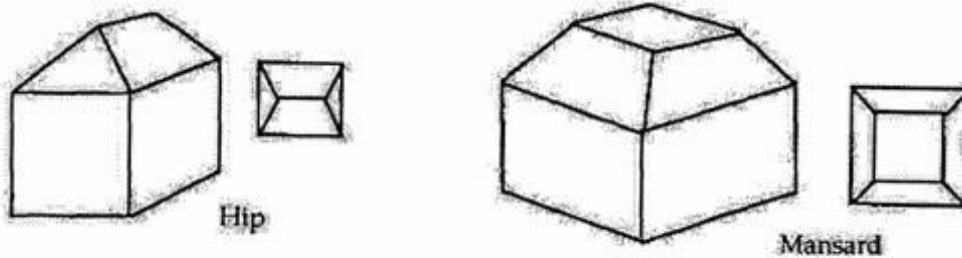

5.14.2 Guidelines for New Construction. Contemporary roofing materials are available in a wide variety of sizes, materials, colors and designs. The type of building: commercial, residential or accessory to residential is a major factor in determining the appropriate roofing material to use. Today's requirements for fire safety must not be overlooked. Fiberglass matt composition and fire retardant treated sawn/milled wood shingles are the preferred materials for use within the district. Mechanical systems and other devices which are roof mounted are to be designed in such a way that they are not visible from the street and are harmoniously incorporated into the overall building design.

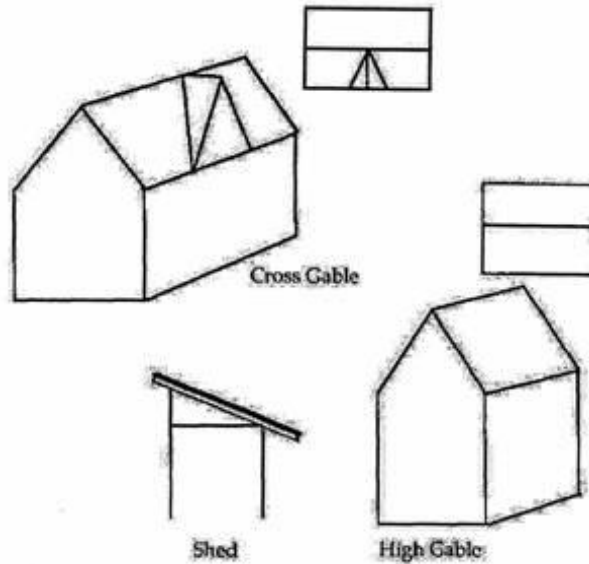

SECTION XXXX:

That Title 18 Appendix (CARSON CITY DEVELOPMENT STANDARDS), Division 5 (HISTORIC DISTRICT), Section 5.15 (Guidelines for exterior siding materials) is hereby amended (**bold, underlined** text is added, [~~stricken~~] text is deleted) as follows:

5.15 Guidelines for exterior siding materials.

The exterior siding materials found in the district include the full range of materials used in the 19th to mid 20th centuries. The most typical is a horizontal wood siding. Generally a horizontal "drop" (shiplap) or clapboard was used. It was not uncommon for milled shingles to be utilized to accent gable ends or other similar portions of a structure. Often these shingles were decorative in nature having sculptured ends so that a variety of textural effects could be achieved. The entire structure was never covered with shingles. Mid-century houses used wide shakes and asbestos shingles. A few residences utilized brick, stone, concrete block or stucco. Other exterior sidings include vertical board and batten and corrugated sheet or standing seam metal. These were typically used on outbuildings. Brick, cut stone and rubble stone masonry and/or combinations were used primarily on commercial buildings. Historically, buildings in the district were painted, often in several colors - they were not stained or left "natural." The colors varied and often several colors were used on the same building to highlight the architectural design. Currently, there are paints as well as opaque stains available for exterior finishes. The HRC can provide assistance to owners wishing more information regarding paint and/or stain colors.

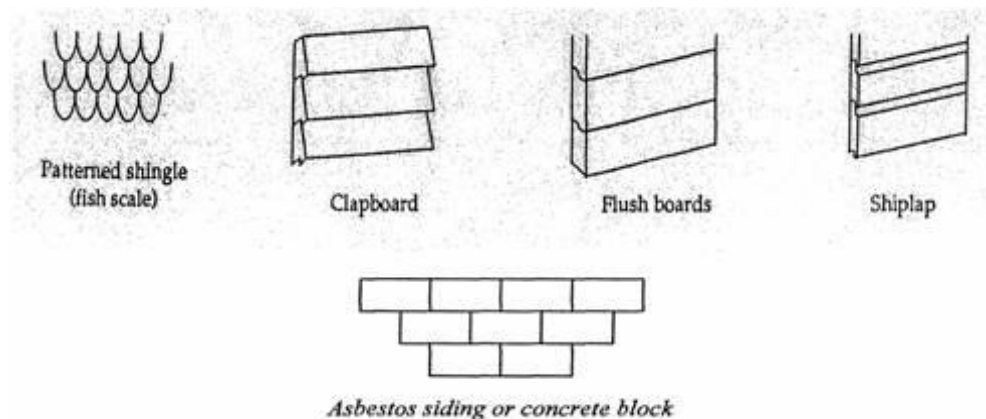

- 5.15.1 Guidelines for Historic Buildings. The original exterior siding material shall be retained and repaired when at all possible. When replacement is necessary the new material shall match the original in size, design, composition and texture. The use of steel, aluminum and vinyl siding materials is not appropriate for historic buildings. (Standard Number: 6, 2)

When contemplating work on the exterior of a historic building, cleaning the existing material should be the first step to determine its condition and a course of action. Cleaning shall be by the gentlest means possible. Sandblasting and other cleaning methods which cause damage to original historic materials shall not be undertaken. (Standard Number: 7)

- 5.15.2 Guidelines for New Construction. New construction within the district needs to be compatible with the historic styles present. The type of building, i.e. residential, outbuilding, or commercial, is a major factor in deciding on an appropriate siding material. Authentic materials such as wood shiplap or clapboard siding are strongly encouraged. Contemporary materials such as masonite or seamless steel are acceptable

when sensitively utilized and properly designed and applied. The use of vinyl siding is highly discouraged. (Standard Number: 6)

SECTION XXXX:

That Title 18 Appendix (CARSON CITY DEVELOPMENT STANDARDS), Division 5 (HISTORIC DISTRICT), Section 5.16 (Guidelines for windows) is hereby amended (**bold, underlined** text is added, [~~stricken~~] text is deleted) as follows:

5.16 Guidelines for windows.

The majority of buildings in the Historic District are characterized by 19 century styles of architecture. A basic design characteristic of these styles is symmetrically placed, vertically proportioned windows. Houses built in the 1930s to 1960s used in addition to the above, metal framed windows such as casements and picture windows.

5.16.1 Guidelines for Historic Buildings. Original windows shall be retained and repaired when at all possible. When replacement is necessary a window of duplicated design shall be used. The size, pane configuration, design and trim shall replicate that of the original. Original trim and surrounds are to be retained when windows are replaced. Bronzed aluminum framed windows are not appropriate for use in a historic building. Stained glass windows were not commonly used in the buildings of the district. Original stained glass windows are very valuable and should be retained. The addition of stained glass windows into openings which did not historically have stained glass is discouraged. (Standard Number: 2, 6)

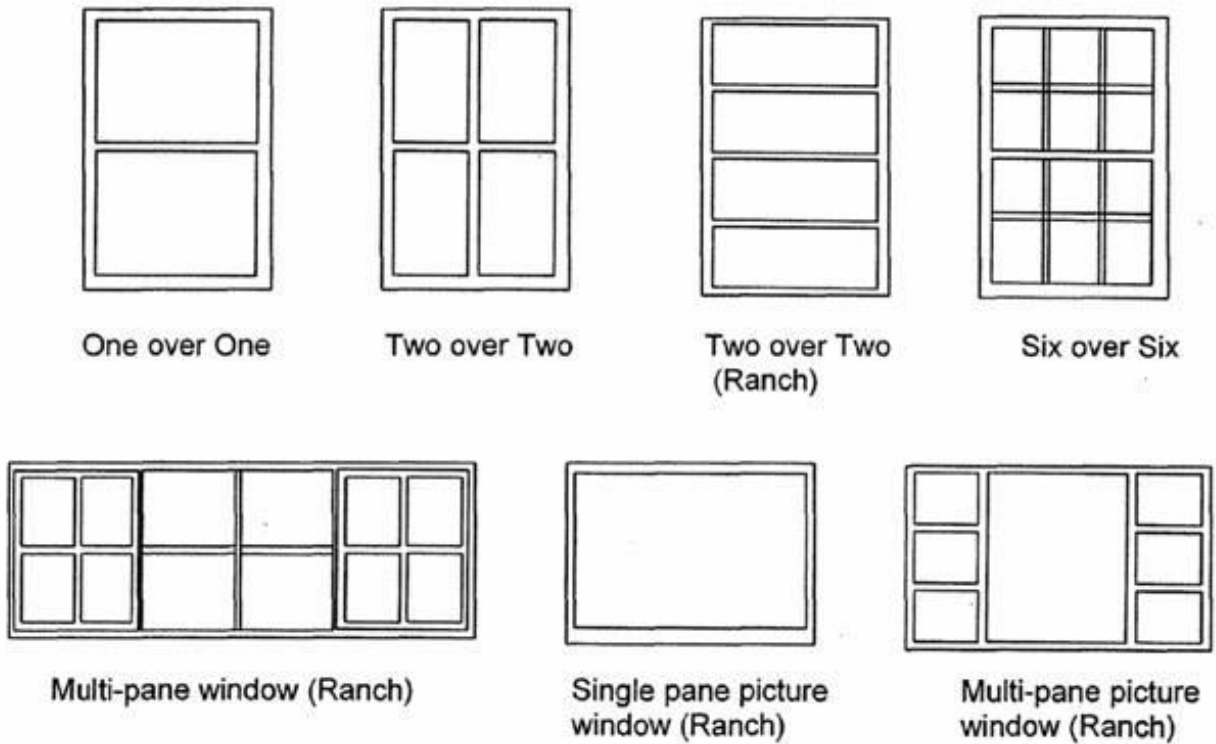

5.16.2 Guidelines for New Construction. The overall style of the new building will determine the appropriate design characteristics of the windows to be used. Windows for new buildings emulating 19th or early 20th century designs should emulate one of the 19th or early 20th century window styles and shall be vertically proportioned with a minimum ratio of 2 horizontal to 3 vertical and shall be single or double hung. Windows for new buildings emulating mid-20th century designs should use windows found in designs of those era (c. 1930-1960). The use of smoked, mirrored or tinted glass is not appropriate for use in the district.

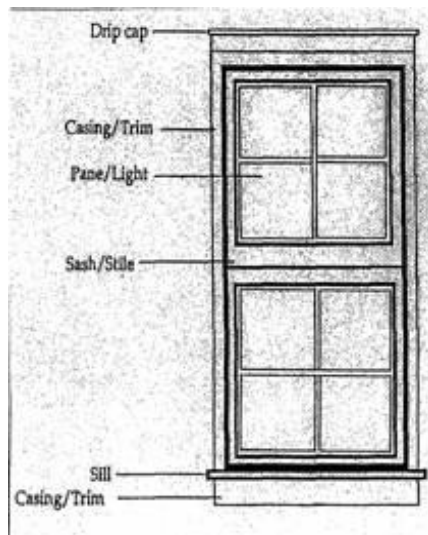

SECTION XXXX:

That Title 18 Appendix (CARSON CITY DEVELOPMENT STANDARDS), Division 5 (HISTORIC DISTRICT), Section 5.17 (Guidelines for doors) is hereby amended (**bold, underlined** text is added, [~~stricken~~] text is deleted) as follows:

5.17 Guidelines for doors.

Doors are an important design element of any building. Their location and style contributes to the overall character and frequently act to define the style of the building. Typically even the simplest historic homes have beautifully paneled doors. Original doors have often been replaced by newer inappropriate doors under the false assumption that greater energy efficiency can be achieved. Properly executed repairs and/or replacement of jams, thresholds, stop moldings, hinges and weather stripping will achieve the same energy efficiency and maintain the historic value. Older doors may have dried and shrunk in size. Numerous lock sets, latches and/or strike plates may have been installed in the door. Glass panels may have been removed and replaced with wood or other material. Original doors, however, are probably one of the most easily reconstructed elements of a building. They are generally constructed of high quality materials, most often have design characteristics which are unavailable in today's market and can be easily removed from the building for repairs in a specialized shop.

- 5.17.1 Guidelines for Historic Doors. Original doors shall be retained, repaired and replaced in their original locations when at all possible. When replacement is necessary the original shall be matched in color, size, material, design, ornamentation and configuration. The original trim and surround molding should be retained intact and/or duplicated when a door is replaced. (Standard Number 2, 3, 5, 6)
- 5.17.2 Guidelines of New Doors in Historic Buildings. The addition of a new door may be warranted for a building to properly function in a modern use. When new doors are to be installed a contemporary design which is sympathetic and harmonious with the original doors shall be used. The placement of the new openings shall not disrupt the original design of the building. (Standard Number: 2, 3, 5, 6, 9, 10)
- 5.17.3 Guidelines for Doors in New Construction. The overall style of the new building will determine the appropriate design characteristics of the doors to be used. Doors and entries make a strong design statement for any building. Balance, proportion, rhythm, scale and emphasis must all be considered when determining the style and design of doors. The use of highly ornamented and/or carved wood doors is discouraged. Likewise entry sidelights and/or transom windows should be simple in design.

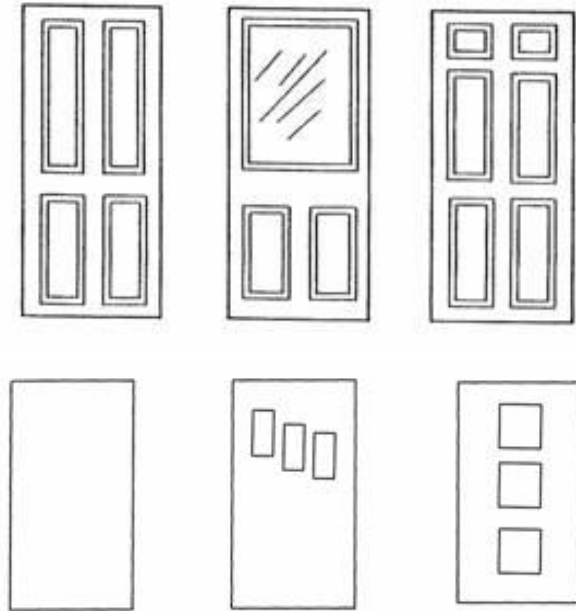

Ranch Style Doors

SECTION XXXX:

That Title 18 Appendix (CARSON CITY DEVELOPMENT STANDARDS), Division 5 (HISTORIC DISTRICT), Section 5.18 (Guidelines for masonry elements) is hereby amended (**bold, underlined** text is added, [~~stricken~~] text is deleted) as follows:

5.18 Guidelines for masonry elements.

Masonry elements found in the historic district include brick or cut stone foundations, porches and/or basements, and entire stone or brick buildings. Some masonry retaining walls and/or fences are also found. Masonry as an architectural design element generally produces a powerful visual image and imparts a sense of permanence and strength. Careful consideration, therefore, needs to be given all designs which incorporate masonry elements.

5.18.1 Guidelines for Historic Buildings. The original masonry material shall be retained and repaired when at all possible. When replacement is necessary the new material shall match the original in size, design, composition and texture. Often repointing the original masonry elements is all that is necessary. When repointing, it is imperative to determine the composition of the original mortar. Repointing historic masonry with a contemporary mortar mix containing Portland cement can cause severe damage to the building. Repointing should be accomplished with a mortar that matches the original in color, composition and strength. (Standard Number: 6, 2)

NOTE: When contemplating work on the exterior of a historic building, cleaning the existing material should be the first step to determine its condition and a course of action. Cleaning shall be by the gentlest means possible. Sandblasting and other cleaning methods

which cause damage to original historic materials shall not be undertaken. (Secretary of Interior Standard Number: 7)

5.18.2 Guidelines for New Construction. In contemporary construction, brick or stone is used as a veneer over a wood frame, concrete block or a poured concrete structural frame. When using brick, a wire cut standard red brick with a flush tooled joint is strongly recommended. When using stone, the size, shape, color, texture and style of laying should replicate the visual qualities found in historic construction where the stone composed the major structural element of the building. The use of "culture stone" or other artificial materials is discouraged.

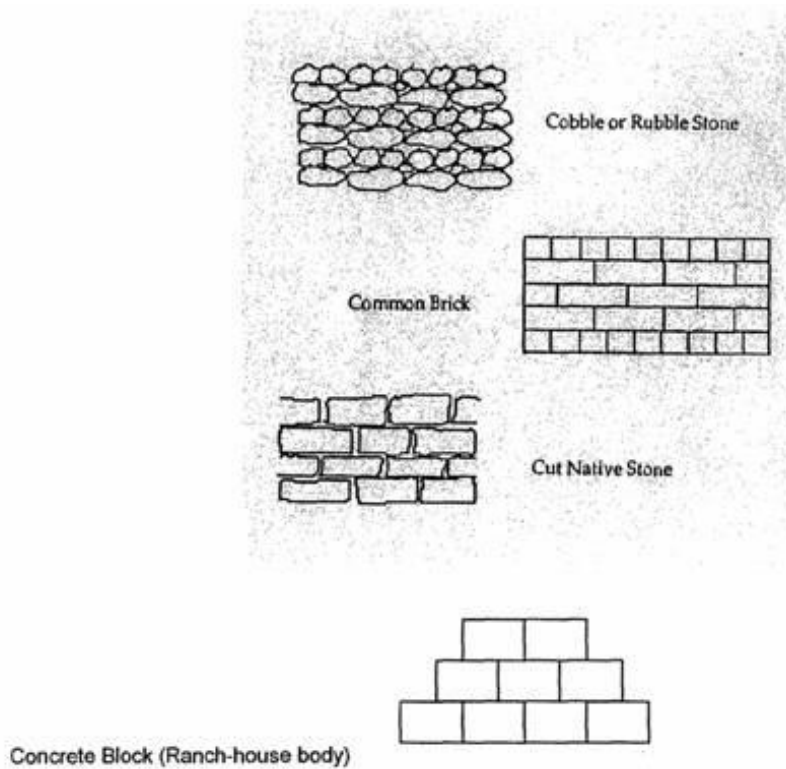

SECTION XXXX:

That Title 18 Appendix (CARSON CITY DEVELOPMENT STANDARDS), Division 5 (HISTORIC DISTRICT), Section 5.19 (Guidelines for porches) is hereby amended (**bold, underlined** text is added, ~~stricken~~ text is deleted) as follows:

5.19 Guidelines for porches.

Porches constitute a significant architectural feature of any building; they are a character defining design feature. The placement, style, scale, massing and trim detail of porches in Carson City reflect a wide range of architectural styles. Because of their architectural impact porches are of particular concern in the historic district. A porch of inappropriate scale, placement and/or design, added to a historic building which did not have a porch originally, can be particularly detrimental to the historic integrity of the building and the character of the district as a whole.

Conversely porches can be effectively utilized as a building feature in new construction to create a contemporary architectural design compatible with the historic district's character.

5.19.1 Guidelines for Historic Buildings. A porch that is part of the original design of a historic building shall be maintained in its original configuration, design, style and detailing if at all possible. If suitable documentary evidence can be presented which demonstrates the original existence of a porch which no longer exists, the porch may be reconstructed to match the original as best as possible. If a porch cannot be demonstrated to have originally existed on the building, a porch may be added with the condition that the configuration, design, style and detailing are suitable and compatible with the architectural style of the building and does not adversely impact the historic integrity of the building. Any new additions to the building shall be performed in such a manner that if removed in the future the original building will not be adversely affected. (Standard Number: 2, 3, 4, 5, 6, 9, 10)

5.19.2 Guidelines for New Construction. New construction in the district shall be encouraged to utilize porches as suitable character defining architectural elements. The configuration, design, style and detailing of the porch needs to be suitable and compatible with the architectural style of the building and the buildings in the immediate vicinity. Porches shall not be approved when their design would adversely affect other buildings in the immediate vicinity or the district as a whole, or where the design is obviously incongruous with the building.

NOTE: The roof style and slope are critical design elements of a porch. Careful attention to these elements is necessary in both historic and new buildings with porches.



NOTE: The roof style and slope are critical design elements of a porch. Careful attention to these elements is necessary in both historic and new buildings with porches.

SECTION XXXX:

That Title 18 Appendix (CARSON CITY DEVELOPMENT STANDARDS), Division 5 (HISTORIC DISTRICT), Section 5.20 (Guidelines for exterior trim details) is hereby amended (**bold, underlined** text is added, ~~stricken~~ text is deleted) as follows:

5.20 Guidelines for exterior trim details.

Although often perceived to be insignificant or frivolous, trim details play a very important part of defining a building's character. Designs for new buildings as well as additions and/or alterations to historic buildings should incorporate the appropriate trim details. The detailing can

act to harmonize a building with its neighbor or tie a new addition to the original. Within the architectural styles represented in the district the following exterior trim details can be identified:

- a) Brackets
- b) Boxed cornice with eave returns
- c) Decorated cornice
- d) Decorated bargeboards
- e) Quoins
- f) Corner boards
- g) Spindle/spool millwork
- h) Pediments
- i) Dentils
- j) Columns

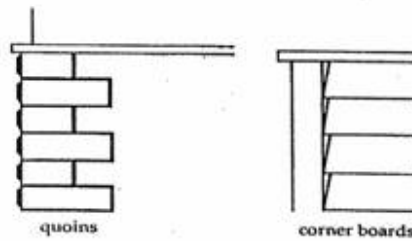

5.20.1 Guidelines for Historic Buildings. Original trim elements should be retained and repaired when at all possible. Trim that is inconsistent with the original building style and design shall not be added. (Standard Number: 2, 3, 5, 6)

5.20.2 Guidelines for New Construction. Trim details need to be given careful and thorough consideration in any new building design. They represent a design opportunity for establishing the compatibility of a new building within the context of the district. (Standard Number: 9, 10)

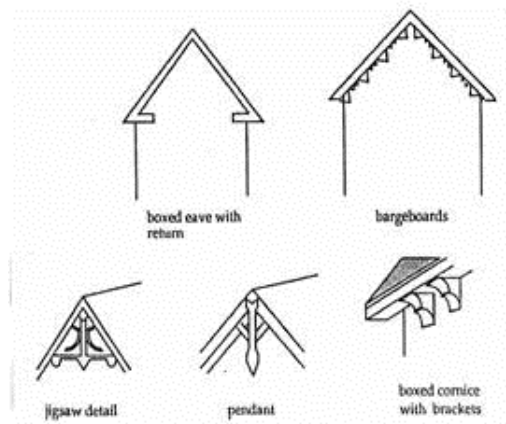

SECTION XXXX:

That Title 18 Appendix (CARSON CITY DEVELOPMENT STANDARDS), Division 5 (HISTORIC DISTRICT), Section 5.21 (Guidelines for additional architectural features) is hereby amended (**bold, underlined** text is added, [~~stricken~~] text is deleted) as follows:

5.21 Guidelines for additional architectural features.

In review of the distinctive architectural features of the styles represented in the district, the following additional architectural features are exhibited. Designs for new buildings as well as additions or alterations to historic buildings can effectively incorporate one or more of the following design elements.

- 5.21.1 Dormers can be a very cost effective method of increasing the usable floor space of a building. Often historic buildings are modified by the addition of dormers. Care must be taken when adding dormers to historic buildings that the scale, massing and proportion of the building is not disrupted. In new construction dormers can play a very effective role in harmonizing the contemporary building design with the existing historic styles. (Standard Number: 2, 3, 5, 9, 10)
- 5.21.2 Transom Windows. Transom windows over doors, particularly front entry doors, are a common feature of historic buildings in the district. (Standard Number: 2, 3, 5, 9, 10)
- 5.21.3 Bay Windows. Bay windows are often a character defining element of a building. As an exterior feature they can often provide a focal component of the design. Proportion, rhythm, scale, symmetry and emphasis are important considerations in the design and placement of a bay window. (Secretary of Interior Standard Number: 2, 3, 5, 9, 10)
- 5.21.4 Recessed Door Entries. Recessed door entries are often found in the district. In new construction, recessed entries can play a very effective role in harmonizing the contemporary building design with existing historic styles. (Secretary of Interior Standard Number: 2, 3, 5, 9, 10)
- 5.21.5 Barrier Free Handicapped Access. The accommodation of ramps, elevators, lifts and other building elements designed to allow handicapped access can be a difficult design problem. Scale, massing, proportion, detailing and balance all need to be carefully considered. (Secretary of Interior Standard Number: 2, 9, 10)

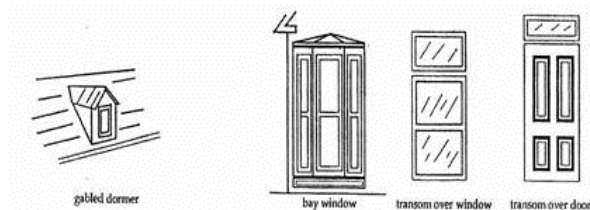

SECTION XXXX:

That Title 18 Appendix (CARSON CITY DEVELOPMENT STANDARDS), Division 5 (HISTORIC DISTRICT), Section 5.22 (Guidelines for exterior lighting) is hereby amended (**bold, underlined** text is added, [~~stricken~~] text is deleted) as follows:

5.22 Guidelines for exterior lighting.

Exterior lighting in the district is characterized by public fixtures illuminating common areas and private fixtures illuminating signs, yards and buildings. Historically, exterior lighting was generally restricted to illuminating entry and porch areas. Contemporary attitudes have expanded the desire for exterior lighting, and modern technology has provided the ready availability and relatively low cost.

The design of exterior lighting involves two elements: the fixture and the illumination pattern produced by the fixture. Both elements need to be considered carefully in the review of any application. The illumination pattern should be functional, but not intrusive on neighbors. New fixtures which provide outdoor flood lighting shall be placed so that they are hidden from view during daylight hours.

5.22.1 Guidelines for Historic Buildings. The addition of light fixtures and illuminating patterns to historic properties shall be undertaken with sensitivity to the property and its neighbors. Original lighting fixtures and illuminating patterns shall be retained when at all possible. (Secretary of Interior Standard Number: 2, 3, 5, 6)

5.22.2 Guidelines for New Construction. Exterior lighting in new construction needs to be sensitively designed. Lighting fixtures should reflect the style and design of the new building. The illumination pattern of the lighting should not intrude, but should compliment the building and its environs. (Secretary of Interior Standard Number: 9, 10)

SECTION XXXX:

That Title 18 Appendix (CARSON CITY DEVELOPMENT STANDARDS), Division 5 (HISTORIC DISTRICT), Section 5.23 (Guidelines for signs) is hereby amended (**bold, underlined** text is added, [~~stricken~~] text is deleted) as follows:

5.23 Guidelines for signs.

Signs in the Historic District are governed by both this Division and Division 4 of the Development Standards. Signage in the Historic District is generally concerned with the conversion of original residential buildings to light office use or with new buildings which have been constructed as commercial buildings in a style compatible with the basic residential nature of the district.

All signs must have an appearance, color, size, texture and design which conform to the sign codes and to the historic character of the district. Signs should also closely match stylistically with the architectural style of the building. Additionally, the location and/or method of attachment of the sign will be considered. The HRC will review all sign applications within the context of the building and the location in the district.

NOTE: Any sign placed in the district must meet the standards of Division 4 and be approved by the HRC.

SECTION XXXX:

That Title 18 Appendix (CARSON CITY DEVELOPMENT STANDARDS), Division 5 (HISTORIC DISTRICT), Section 5.24 (Guidelines for fences) is hereby amended (**bold, underlined** text is added, [~~stricken~~] text is deleted) as follows:

5.24 Guidelines for fences.

Fences serve a variety of purposes for a property owner. They can define property lines, provide security and protection from trespass, furnish safety for children and pets, provide visual screens for privacy and serve as protection from the elements. The design of a fence is a critical element in the overall visual quality of a property and how it relates to its neighbors. It can also be important from a public safety standpoint, particularly on corner lots. Typically front yards in the district were delineated by low profile, wood picket style fences. A few metal and masonry fences can be found as well.

A fence design must be considered in context. Scale, rhythm, material and style are the critical design elements of a fence. The fence design must be compatible with the building as well as with the surrounding property. A fence can provide a delicate design element which will greatly enhance a property.

5.24.1 Guidelines for Historic Fences. Original fences must be retained and repaired whenever possible. When reconstruction is necessary, the original fence must be matched in color, material, size, scale, texture and composition. New fences should emulate historic styles and designs found in the district. (Standard Number: 2, 4, 5, 6). In accordance with this requirement, and unless an exemption is granted under circumstances deemed appropriate at the discretion of the historic resources commission, when reconstruction of a fence occurs:

- a. The historic characteristics of the property must be preserved, including, without limitation, any distinctive feature, finish, construction technique or craftsmanship and any individual feature not originally part of the property but which, over time, has acquired historic significance.
- b. The removal of any historic feature or finish, or the modification or alteration of any such material, feature or finish that contributes to the historic character of the property, is prohibited.

- c. A deteriorated feature or finish must, whenever possible, be repaired in lieu of replacement.
- d. A historic feature or finish that has severely deteriorated or is otherwise in a state of disrepair such that replacement in lieu of repair is necessary, the replacement feature or finish must, to the greatest extent possible, match the original feature or finish in material, design, color, texture and all other visual aesthetics.

5.24.2 Guidelines for New Fences. The appropriate design for a new fence must be determined by its intended function and its location. A new fence must not be constructed in any manner which adversely affects the primary views of any building. A fence should consist of a design that will enhance the overall visual presentation of a building and be made from material which is traditionally associated with fences located within the historic district, including wood, wrought iron, decorative woven wire and, in limited circumstances, masonry. A fence should also contribute to the character and defining features of any building in a positive manner. (Standard Number: 9). Unless an exemption is granted under circumstances deemed appropriate at the discretion of the historic resources commission, the use of vinyl for the construction of a new fence is prohibited. If material other than material which is traditionally associated with fences located within the historic district is proposed to be used for the construction of a new fence, the person proposing the use of such material must include in his or her application to the historic resources commission an explanation describing how the material to be used is:

- a. Compatible with the massing, size, scale and existing architectural and construction materials of the property and the property site.
- b. More compatible with the property and the property site than if material which is traditionally associated with fences located within the historic district is used.
- c. Consistent with the historical features of the property and the property site.
- d. Consistent with the massing, size, scale and existing architectural and construction materials used within the historic district.

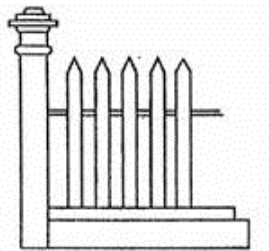

typical fence with corner or gate post

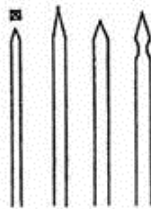

1" X 2" or 1" X 4" typical pickets

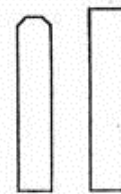

1" X 6" solid board fence

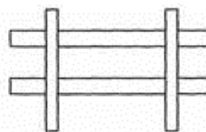

post and rail fence (Ranch)

SECTION XXXX:

That Title 18 Appendix (CARSON CITY DEVELOPMENT STANDARDS), Division 5 (HISTORIC DISTRICT), Section 5.25 (Guidelines for landscape elements) is hereby amended (**bold, underlined** text is added, [~~stricken~~] text is deleted) as follows:

5.25 Guidelines for landscape elements.

The Carson City Historic District is characterized by a typical rectangular grid street system without alleys. The streets vary in width, but all are characterized by "L" shaped concrete curbs and gutters, a sidewalk and planting strip between the street and sidewalk. Generally this planting strip contains a row of deciduous trees and lawn. Individual lots are usually rectangular in shape with the main building centered on the parcel and a front setback which allows for a modestly sized front yard. Front yards are typically delineated by a low profile fence, with a gate and walkway leading to the front entry. Accessory buildings are often found in rear yards. These basic elements create a strong visual quality to the district which is consistent and should be encouraged. 2 unique landscape elements in the district are hitching posts (generally of cast iron) and carriage steps (generally of cut stone). These are most likely to be found in the planting strip between the Street and the sidewalk. These should be retained.

- 5.25.1 Guidelines for Historic Properties. Historic landscape features should be retained when at all possible. Fences, trees, hitching posts, carriage steps, sidewalks and walkways provide a visual consistency and harmony of setting to the district. (Standards Number: 2, 3, 4, 5, 9)
- 5.25.2 Guidelines for New Construction. New construction in the district should include landscape elements which reflect the scale, rhythm, texture, material, color, style and visual qualities of the historic landscape present. (Standard Number: 9, 10)
- 5.25.3 Parking Areas. The construction of parking areas in association with commercial development in the district often presents a difficult design task. They need to be designed and located in such a manner that their effect on the district's environs is minimized. They also need to be landscaped with appropriate plant material to provide a visual screen and to soften their impact on the site.
- 5.25.4 Satellite Dish Antennas. Satellite dish antennas are an inherently intrusive and incongruous landscape feature in the Historic District. The size, color, texture and location of the dish all contribute to its impact. Dishes shall be placed in the least visible location on the property. A screen of plant material and/or fencing shall also be provided to lessen the visual impact of the installation.
- 5.25.5 Sidewalks. See Carson City Municipal Code (CCMC), Development Standards, Division 12.12, Sidewalks, Curb and Gutter, Driveway Approaches, Curb-Cuts, Alleys and Bikeways.
- 5.25.6 Landscaping and Trees. See CCMC Development Standards Division 3, Landscaping.

SECTION XXXX:

That Title 18 Appendix (CARSON CITY DEVELOPMENT STANDARDS), Division 5 (HISTORIC DISTRICT), Section 5.26 (Guidelines for additions to historic buildings) is hereby amended (**bold, underlined** text is added, [~~stricken~~] text is deleted) as follows:

5.26 Guidelines for additions to historic buildings.

The primary objective of the Carson City historic resources commission (HRC) is to protect and maintain the integrity of the historic resources in the historic district. However, the commission is committed to provide for the development of these resources in such a manner that does not impair their utility. It is recognized that additions are often necessary for a historic building to become functional in a modern context. It is also recognized that additions must be designed to be compatible and not detract from the building, its immediate surrounding or the district as a whole.

5.26.1 Guidelines for Additions to Historic Buildings. Additions to historic buildings need to be compatible in their configuration, design, style, scale, materials and architectural details with the distinctive character defining elements of the building. Additions shall be done in such a manner that they do not destroy significant original historical or architectural material, and if removed in the future, will not impair the essential form and integrity of the building nor damage historic fabric. Additions which seek to create an earlier appearance shall not be approved. Additions which are obviously incongruous to the building, or buildings in the immediate vicinity, or the district shall not be approved. (Standard Number: 9, 10)

5.26.2 Guidelines for Additions to Nonhistoric Buildings. Additions to non-historic buildings in the district will be treated in the same manner as additions to historic buildings, except that maintaining original building fabric will not be a consideration.

SECTION XXXX:

That Title 18 Appendix (CARSON CITY DEVELOPMENT STANDARDS), Division 5 (HISTORIC DISTRICT), Section 5.27 (Guidelines for new construction) is hereby amended (**bold, underlined** text is added, [~~stricken~~] text is deleted) as follows:

5.27 Guidelines for new construction.

New construction which is appropriately designed is encouraged by the Carson City historic resources commission (HRC). The historic district should be an active and vital part of the city. New construction should look new and reflect the technology, building materials and design ideas of the present era. The design of new construction needs to be compatible and respectful of

the historic building stock that surrounds it so that visual conflict and confusion are avoided. There is no formula that will guarantee "good design". There are specific elements of building design which can be identified, and therefore, addressed in a review process so that consistency can be achieved.

The following elements shall be individually assessed for their degree of appropriateness for each project.

- 5.27.1 Scale and Massing. The overall size and height of the new building should be consistent with the surrounding buildings.
- 5.27.2 Shape. The overall shape of the building, particularly its roof type, height, and design emphasis (horizontal or vertical) should be consistent and harmonious with others in the environs.
- 5.27.3 Setback. The front and side yard setbacks for the building should be approximately the same as others in the surrounding area and conform with CCMC Development Standards, Division 1, Land Use and Site Design. 5.27.4 Site Elements. When at all possible avoid substantial site alteration by importing or exporting fill materials. Generally speaking vacant lots in the district were once occupied by a building. Attempt to place the new building as near as possible to the same grade as the original. Carefully consider the placement and relationship of the public sidewalk, side and front yard fences, driveway, gardens and accessory buildings when determining the location of the new building on the lot.
- 5.27.5 Materials. Exterior siding should reflect the prevailing style of the neighborhood. A vertical or diagonal style siding should not be used when the dominant style is a horizontal drop or shiplap type. The exterior siding should blend in, not stand out.
- 5.27.6 Windows and Doors. The rhythm and arrangement of the windows and doors should reflect the style of the building design and the predominant patterns found in existing buildings of the area. The ratio of the total surface area of openings to total wall surface area of new buildings should reflect that of historic buildings in the environs.
- 5.27.7 Details and Other Elements. Trim details are often the single most relevant design feature which can be utilized to give harmony and compatibility to a new building. If existing buildings have boxed eaves, do not leave rafter tails exposed. If windows and doors typically have fanciful trim, incorporate trim with architecturally equal weight. If trim work is typically simple, do not use "ginger bread". Seek to design the new building so that the trim and architectural details compliment the existing buildings in the area.
- 5.27.8 Floor Elevations. The elevation of the first floor in relation to the street and the finish grade of the lot can often be a critical design feature. For example, if surrounding buildings normally have steps leading from street level up to the first floor level, then the new building should have a similar entrance level.

NOTE: It is suggested that each design element outlined in this document be individually reviewed for more specific information.

SECTION XXXX:

That Title 18 Appendix (CARSON CITY DEVELOPMENT STANDARDS), Division 5 (HISTORIC DISTRICT), Section 5.28 (Resources) is hereby amended (**bold, underlined** text is added, [~~stricken~~] text is deleted) as follows:

5.28 Resources.

For further information on Carson City's historic architecture, architectural styles, or rehabilitation sources and techniques, the following resources are recommended. The department of planning and community development has a small resource library concerning historic architecture and rehabilitation practices; these resources are available for use by the public within the office and are starred (***) below.

For additional information, contact the State Historic Preservation Office, 100 North Stewart Street, Carson City, NV 89701, (775) 684-3448.

Carson City Architecture

Carson City Historic Resources Inventory. 1980, updated 1988. Prepared by Historic Environment Consultants, Sacramento, CA and updated by Rainshadow Associates, Carson City, NV. ***

Cultural Resources of Carson City National Register nomination. Prepared by Patricia Lawrence-Dietz for Carson City, 1980. ***

Stewart Institute, Carson Indian School National Register nomination. 1982. Prepared by Kent L. Seavey for the Inter-Tribal Council of Nevada. ***

Historic American Building Survey of Carson City. National Park Service, Washington, D.C., 1972.

Architectural Styles

Blumenson, John J.G. Identifying American Architecture: A Pictorial Guide to Styles and Terms 1600-1945. American Association for State and Local History, Nashville, 1981.

Foley, Mary Mix. The American House. Harper and Row, New York, 1979.

Gottfried, Herbert, Jennings, Jan. American Vernacular Design 1870-1940: An Illustrated Glossary. VNR Company, New York, 1985.

McAlester, Virginia and Lee. A Field Guide to American Houses. Alfred A. Knopf, Inc. New York, 1984. ***

Whiffen, Marcus. American Architecture Since 1780: A Guide to the Styles. MIT Press, Cambridge, Mass., 1969. ***

Rehabilitation

Grow, Lawrence. The Fifth Old House Catalogue. The Main Street Press, Pittstown, New Jersey, 1986. ***

National Park Service. Preservation Briefs. U.S. Government Printing Office. Washington, D.C., 1979-present.

National Park Service. Respectful Rehabilitation: Answers to Your Questions about Old Buildings. The Preservation Press, Washington, D.C., 1982. ***

National Park Service. The Secretary of Interior's Standards for Rehabilitation and Guidelines for Rehabilitating Historic Buildings. U.S. Department of the Interior, Washington, D.C., 1983. ***

Oakland, California Planning Department. Rehab Right. City of Oakland, California, 1980. ***

The Old House Journal. 1976 through the present.

SECTION XXXX:

That Title 18 Appendix (CARSON CITY DEVELOPMENT STANDARDS), Division 6 (DOWNTOWN MIXED-USE DISTRICT), Section 6.1 (Purpose) is hereby amended (**bold, underlined** text is added, [~~stricken~~] text is deleted) as follows:

6.1 Purpose.

The purpose of these development standards is to establish the design-oriented standards for the downtown mixed-use district pursuant to the purposes stated in Title 18, Chapter 18.07, Downtown Mixed-Use District.

SECTION XXXX:

That Title 18 Appendix (CARSON CITY DEVELOPMENT STANDARDS), Division 6 (DOWNTOWN MIXED-USE DISTRICT), Section 6.2 (Applicability) is hereby amended (**bold, underlined** text is added, [~~stricken~~] text is deleted) as follows:

6.2 Applicability.

These design standards and guidelines shall apply to all new development, infill, redevelopment, signs, exterior modifications and major renovation projects occurring within the DT-MU district, except as provided in Section 6.3, Exemptions, or as otherwise noted within individual sections of this division. If a conflict should arise between the DT-MU district and other sections of this code (as applied to a particular development), the requirements set forth in the DT-MU district shall prevail.

SECTION XXXX:

That Title 18 Appendix (CARSON CITY DEVELOPMENT STANDARDS), Division 6 (DOWNTOWN MIXED-USE DISTRICT), Section 6.3 (Exemptions) is hereby amended (**bold, underlined** text is added, [~~stricken~~] text is deleted) as follows:

6.3 Exemptions.

Exemptions to the regulations contained in this chapter may apply as follows:

1. Projects involving only work, maintenance or repairs to the interior of a building or structure and that do not affect exterior appearances are exempt from this chapter.
2. Projects involving only ordinary maintenance or the replacement of similar or identical materials of an existing building or structure are exempt from this chapter.
3. Parcels, property or structures located within the historic district and subject to review by the historic resource commission are exempt from the design-oriented elements of these standards.

SECTION XXXX:

That Title 18 Appendix (CARSON CITY DEVELOPMENT STANDARDS), Division 6 (DOWNTOWN MIXED-USE DISTRICT), Section 6.4 (Downtown character areas) is hereby amended (**bold, underlined** text is added, [~~stricken~~] text is deleted) as follows:

6.4 Downtown character areas.

The DT-MU district is comprised of three downtown character areas, the boundaries of which are depicted on the regulating plan—DT-MU district map. The downtown character areas establish a framework for the scale of development that is desired in different locations within downtown.

Main Street Mixed-Use. The purpose of the Main Street Mixed-Use character area is to provide opportunities for infill and redevelopment, while retaining the traditional "Main Street" character and scale of Carson Street. To support this objective, building heights will be limited along the Carson Street frontage and adjacent to the State Capitol Complex and other historic structures, but will be permitted to "step up" away from the street—providing for a broader range of development opportunities. Active uses, such as retail shops and restaurants, as well as urban residential units, are desired throughout the character area to promote a lively street environment and expanded hours of activity.

Urban Mixed-Use. The purpose of the urban mixed-use character area is to provide for urban-intensity mixed-use development in areas of downtown that contain larger tracts of vacant or underutilized land. It is intended to provide opportunities for concentrations of active uses such as convention space, casinos, hotels, urban residential or similar uses which typically have more intensive land requirements than could be readily accommodated in other areas of downtown. To support these objectives, building heights in this area are

permitted to be higher than in other character areas within downtown, provided appropriate transitions are provided to the more modest scale of development found along Carson Street, the surrounding neighborhoods, and the State Capitol Complex.

Neighborhood Transition. The purpose of the neighborhood transition character area is to provide a more gradual transition between the more urban patterns of development desired in other locations within downtown and the surrounding residential neighborhoods. To support this objective, building heights are much more restrictive than in other character areas and are required to "step down" towards the surrounding neighborhood and building design becomes less blocky and urban and more residential in character. Uses in this area will tend to be primarily a mix of office and residential, however, a broad range of uses is permitted provided the design of the uses is compatible with the established character of the area.

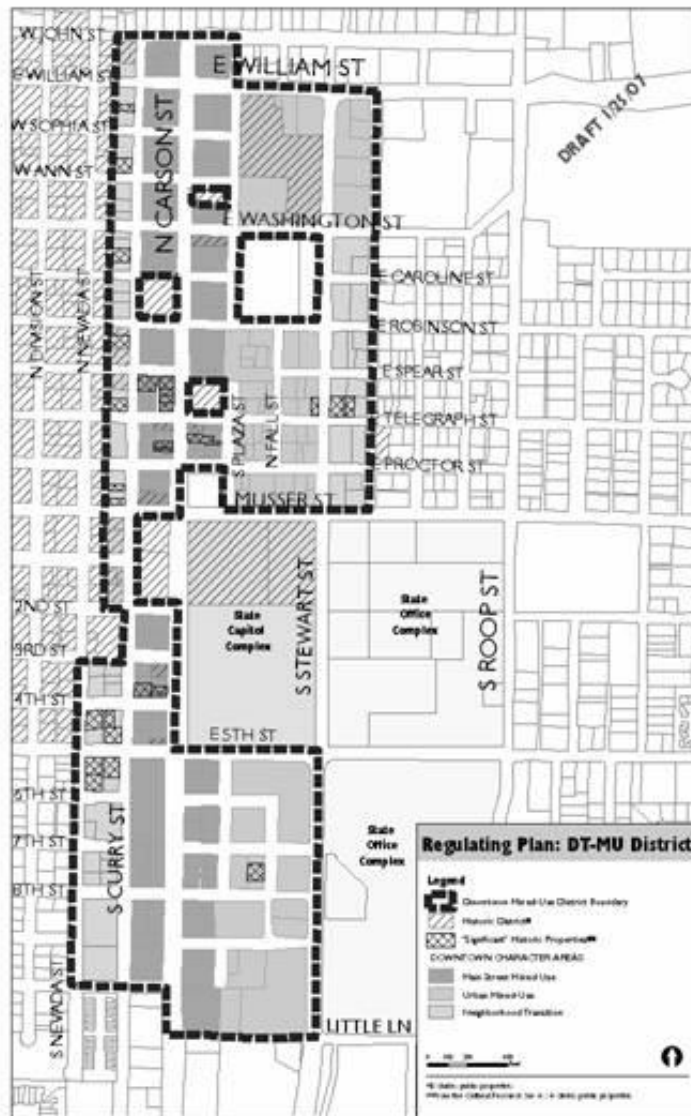

SECTION XXXX:

That Title 18 Appendix (CARSON CITY DEVELOPMENT STANDARDS), Division 6 (DOWNTOWN MIXED-USE DISTRICT), Section 6.5 (Permitted uses) is hereby amended (**bold, underlined** text is added, [~~stricken~~] text is deleted) as follows:

6.5 Permitted uses

This section sets forth the uses that are allowed within the DT-MU district and are intended to supplement the permitted and conditional uses listed in Chapter 18.04, Use Districts, Section 18.04.125, Downtown Mixed-Use, and group uses into specific categories for purposes in these development standards. A mix of uses is encouraged within each character area and may be required in some locations, as specified in this section.

6.5.1 Permitted Use Tables.

A = Allowed (Primary Permitted Use); X = Not Allowed; C = Conditional Use	
Type of Use	
Residential Use Group	
Bed and Breakfast Inn	A
Boarding and Rooming House	A
Dwelling, Single Family	A
Dwelling, Two-Family	A
Dwelling, Multi-Family	A
Live/work dwelling	A
Office/Professional Use Group	
Bank	A
Office	A
Commercial/Service/Retail Use Group	
Adult Entertainment Facility	X
Alcoholic Beverage Sales (accessory to restaurant)	A
Alcoholic Beverages and Liquor, Retail	A
Amusement Arcade	C
Amusement Devices, Sales and Service	C
Automobile Service Station	C
Bakery	A
Bar	A
Brew Pub	A
Caterer	A
Child Care Facility	C
Christmas Tree Sales	A
Community/Regional Commercial/Office	A
Drugstore	A
Equipment Rental (within a building)	C
Farmers Market	A
Gaming Establishment (non-restricted)	C
Gaming (limited)	A
Health and Fitness Club	A
Hotel	A
Motel	C
Outdoor Merchandise Display (subject to Section IV.H.(2)c.)	A

Outside Storage (accessory to primary use only)	C
Parking Lot, Public or Private (as a primary use)	C
Pharmacy	A
Restaurant, with or without outdoor seating	A
Restaurant, with drive-in or drive-through	C
Retail and Personal Services	A
Second Hand Business	X
Street Vendors (subject to Development Standards)	A
Temporary Outdoor Display and Sales subject to Title 18 (Outdoor Sales)	A
Theater	A
Veterinary Clinic	A
Wedding Chapel	A
Civic and Institutional Use Group	
Church, Temple, House of Worship	A
Convention Center	A
Fraternal Association	A
Jail or Correctional Facility	X
Library	A
Museum	A
Open Space	A
Park	A
Public Parking Garage	C
Public Restroom	A
Transit Passenger Facility	A
Public Plazas, Squares, and Community Amenities	A
Public Safety Facilities (police dispatch, fire substations)	A
Information Kiosk	A
School, College or University and Vocational	C

6.5.2 Conditional Use Criteria. In addition to the findings listed in Section 18.02.080 of this code, findings from a preponderance of evidence must indicate that the proposed use:

1. Is consistent and compatible with the character and intent for the downtown character area in which it is proposed;
2. Incorporates or can be incorporated as part of a broader mix of uses to support an active "people-oriented" environment within the downtown character area; and
3. Can be integrated into the more urban development pattern in a manner that is consistent with master plan policies for downtown.

6.5.3 Mix of Uses.



The following standards and guidelines shall apply within the urban mixed-use and main street mixed-use character areas only:

1. **Mix of Uses Encouraged.** To provide for a balance of commercial, office, residential, and civic uses as set forth above, new developments are encouraged to include a mix of two or more distinct types of permitted uses.
2. **Required Mix of Uses—Sites 50,000 Square Feet or Larger.** All developments on sites that exceed 50,000 square feet (roughly 2 blocks) shall include at least one use from the commercial/service/retail use group, as identified in the table above.
3. **Ground Floor Uses.** The incorporation of retail shops and/or restaurants is encouraged at the street level to promote a more active environment for pedestrians and to support residential and office uses located within the same building (on upper floors) or nearby. This configuration of uses is particularly encouraged along Carson Street and other major street frontages, as well as adjacent to major public spaces, where a high level of activity and visibility is desirable. If a limited portion of a structure's ground level will be devoted to retail or restaurant space, such space should be located along those facades adjacent to or most visible from primary street frontages or major pedestrian walkways.
4. **Parking Structures.** Parking structures shall be "wrapped" with retail, office, or residential uses along a minimum of 50 percent of their street frontage to provide visual interest and to create pedestrian activity at the street level. Active uses, such as retail shops and/or restaurants, should be focused along those facades adjacent to or most visible from primary street frontages or major pedestrian walkways. Parking structures as a primary site use are only permitted by special use permit.

SECTION XXXX:

That Title 18 Appendix (CARSON CITY DEVELOPMENT STANDARDS), Division 6 (DOWNTOWN MIXED-USE DISTRICT), Section 6.6 (General development

standards and guidelines) is hereby amended (**bold, underlined** text is added, [~~stricken~~ text is deleted) as follows:

6.6 General development standards and guidelines.

6.6.1 Vehicular and Pedestrian Connections.

1. Intent.
 - a. To maintain a well-defined pattern of urban blocks within downtown that provide frequent connections to adjacent neighborhoods and serve as a framework for a varied mix of uses.
 - b. To maintain frequent pedestrian connections that reflect Carson City's traditional pattern of blocks while allowing for the incorporation of some larger developments and outdoor plazas that require the consolidation of 2 or more blocks, where appropriate.
2. Block Size.
 - a. To the maximum extent feasible, new development shall work within the framework of downtown's existing pattern of blocks to avoid interrupting the grid pattern, creating large "superblocks," and limiting access to adjacent neighborhoods.
 - b. Maximum block lengths resulting from block consolidation shall be limited to 420 feet.
 - c. Where block consolidation is proposed (by right-of-way abandonment), special consideration shall be given to vehicular circulation patterns, flood/drainage pathways, and view corridors to significant features in the area, such as the Capitol building and the mountains to the west.

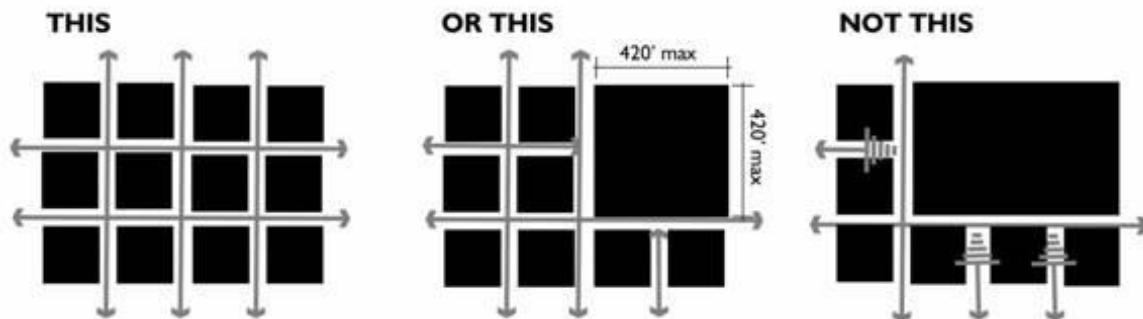

6.6.2 Lighting.

1. Intent.
 - a. To encourage a safe, appealing, and pedestrian-friendly nighttime environment within downtown core.
 - b. To promote the retention of the downtown core's unique nighttime character, as provided by its numerous lighted marques and animated lights.

- c. To ensure that new lighting is compatible with the established character of the downtown and the surrounding neighborhoods.

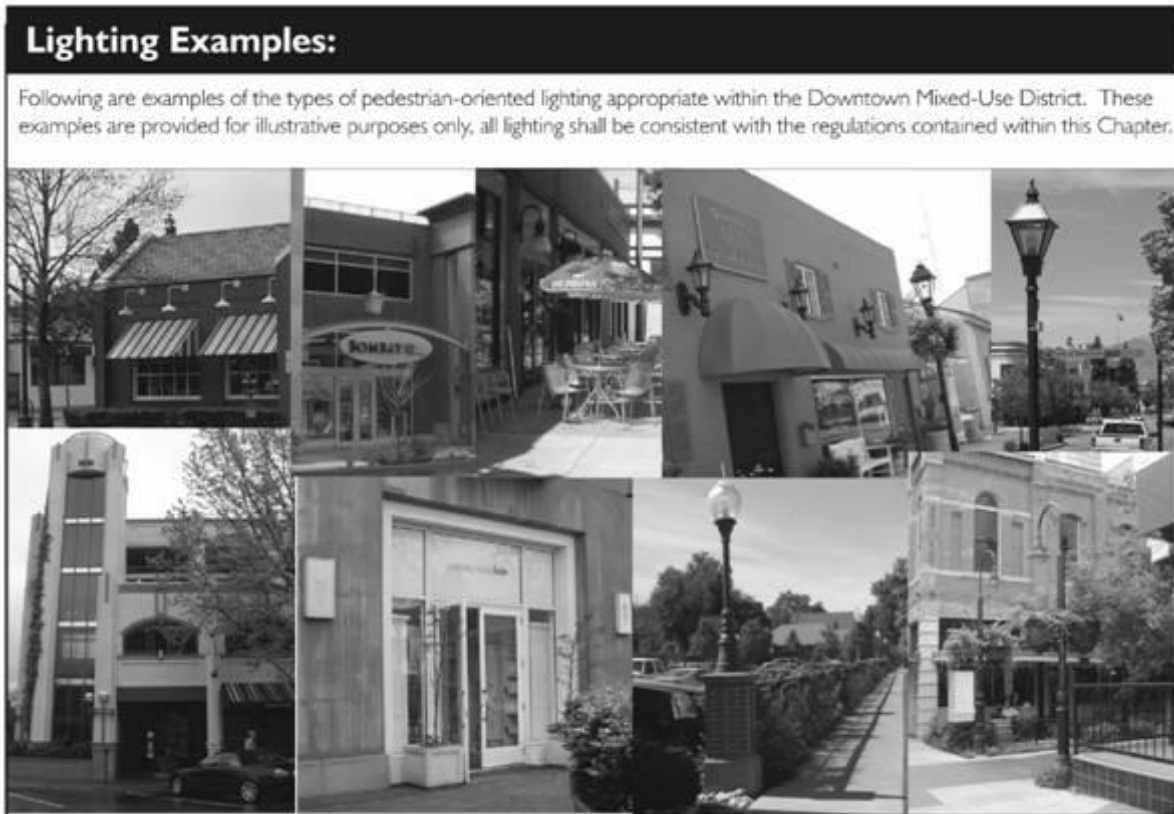

2. Exterior Lighting.
 - a. Low-scale, decorative lighting shall be used to accent architectural details, building entries, or signs. Additional, pedestrian-scaled lighting shall be provided to illuminate sidewalks, enhancing security and extending hours of activity.
 - b. All light sources shall be shielded to protect the city's dark skies and prevent spillover into adjacent residential neighborhoods and the city's downtown.
 - c. Lighted marques and animated lighting, such as chase lights, exist in many locations within downtown and are reflective of the city's gaming traditions. Generally, this type of lighting should be limited to that which exists today; however, new lights may be approved by the director or designee on a project-by-project basis.
 - d. Building façade accent lighting is limited to an upward angle of 45 degrees and must be focused on the building to minimize light trespass onto adjacent properties and into the sky.
3. Storefront Lighting. The incorporation of interior window lighting to highlight displays is strongly encouraged to provide off-hour interest along Carson Street.
4. Street Lights. All street lights, whether intended for pedestrian or auto-oriented purposes, shall be consistent with the city's downtown streetscape plan.

6.6.3 Signage.

1. Intent.
 - a. To encourage a diverse and visually interesting streetscape environment along Carson Street by allowing a variety of types of business signage, as traditionally found; and
 - b. To ensure that signage is compatible with the pedestrian-oriented scale of downtown.
2. General.
 - a. All standards contained in this subsection shall be applied in addition to signage regulations contained in Division 4 of the city's development standards.
 - b. If a conflict between the two articles appears to exist, the standards contained in this article shall take precedence.
3. Materials. Signs shall be constructed of durable, low-maintenance materials that complement the design and character of the building they serve.
4. Preferred Signage Types.
 - a. The use of hanging signs is encouraged for non-gaming uses to reinforce the pedestrian-oriented scale of downtown. Hanging signs and other sign types attached to the front of buildings are permitted to project into the public right-of-way, over the sidewalk, subject to the issuance of an encroachment permit. Hanging signs shall not:
 - (1) Exceed 24 inches in height and 3 feet in length; or
 - (2) Be located where less than 8 feet of clear height can be provided above the sidewalk from the overhang or awning from which they are suspended.
 - b. The creative use of symbols or other images indicative of the use contained within the building in the design of signs is strongly encouraged.
 - c. The use of permanent window signs is encouraged for non-gaming uses to reinforce the pedestrian-oriented scale of downtown. Window signs shall not exceed 10 percent of the window area.
5. Neighborhood Transition Character Area. The following standards shall be applicable within the neighborhood transition character area only.
 - a. The maximum freestanding sign height shall be 6 feet.
 - b. Signs shall be designed to reflect the more residential scale and appearance of the neighborhood transition character area.

PREFERRED SIGNAGE TYPES: NEIGHBORHOOD TRANSITION AREA



Examples of signs designed to reflect a more residential setting, as desired within the Neighborhood Transition character area.

6. Wayfinding Signage. All on-site wayfinding signage shall be consistent with the city's wayfinding signage design standards.
7. A-Frame Signs ("Sandwich-Board" Signs).
 - a. One A-Frame sign is permitted per business per street frontage.
 - b. Sign must be placed against the building the business operates from or within the landscaped area between the sidewalk and the street.
 - c. A minimum of 6 feet of unobstructed sidewalk clearance must be maintained.
 - d. Signs must be professionally manufactured and shall not exceed 32 inches in width and 36 inches in height. However, chalkboard frames with erasable letters are also appropriate.
 - e. All signs shall be in good repair and neatly painted. No attachments to signs are permitted.
 - f. Signs shall not be displayed during non-business hours.
 - g. No sign shall be located where it obstructs the line of sight for passing motorists.

Preferred Signage Types:

Following are examples of the types of pedestrian-oriented signage appropriate within the Downtown Mixed-Use District. These examples are provided for illustrative purposes only. All signs shall be consistent with the regulations contained within this Chapter and Division 4 of the City's Development Standards.

HANGING SIGN EXAMPLES:



WALL & AWNING MOUNTED SIGN EXAMPLES:



PROJECTING SIGN EXAMPLES:



WINDOW SIGN EXAMPLES:



6.6.4 Sustainable Design and Construction.

1. Intent.
 - a. To encourage the use of sustainable building materials and construction techniques in downtown projects, through programs such as the US Green Building Council's LEED (Leadership in Energy Efficiency and Design) program;
 - b. To encourage the use of new and emerging technologies that lead to increased energy conservation for downtown uses; and
 - c. To establish downtown Carson City as a leader in the incorporation of innovative and sustainable design and construction techniques.
2. LEED (Leadership in Energy and Environmental Design). All new residential, commercial, and mixed-use buildings are required to meet basic LEED green building rating system criteria and are required to submit a LEED scorecard as part of the design review process.

6.6.4 Outdoor Gathering Spaces and Community Amenities.

1. Intent.
 - a. To establish a series of safe and inviting outdoor gathering spaces where downtown residents, employees, and visitors may gather, interact, rest, shop, and eat.
 - b. To create an attractive public realm and vibrant pedestrian environment within downtown's most urban character areas.
 - c. To encourage the incorporation of public art, urban recreation spaces, and other community amenities into the design of outdoor gathering space.
2. Improvements in Public Space. Public and private improvements on any city-owned property within the DT-MU district, including without limitation streets, sidewalks, curbs, landscaping and outdoor gathering and urban recreation spaces must conform to the design standards in this chapter and to the city's downtown streetscape plan, as applicable.
3. Provision of On-Site Amenities.
 - a. Development on sites 50,000 square feet or less shall incorporate at least one of the following on-site outdoor gathering spaces or community amenities, and developments on sites larger than 50,000 square feet shall incorporate at least two of the following outdoor gathering spaces or community amenities and one additional amenity for each 25,000 square feet above 50,000 square feet of area, as highly-visible, easily-accessible, focal points:
 - (1) Patio or plaza with a minimum depth and width of 10-feet, and a minimum total area of 150 square feet.
 - (2) Landscaped mini-parks or squares provided such park or green has a minimum depth and width of 10-feet and a minimum total area of 250 square feet.
 - (3) Protected pedestrian walkways; arcades; recessed corner entries with a minimum area of 100 square feet; or easily identifiable building pass-throughs containing window displays and intended for general public access.
 - (4) Outdoor public art, as approved by the city, in an area that is:
 - (i) Visible from an adjacent public sidewalk or street, and
 - (ii) Easily accessed for viewing by pedestrians (e.g., a sculpture mounted to an exterior building wall).
 - (5) Similar feature as approved by the director or designee.
 - b. Outdoor gathering spaces provided in accordance with the above standard shall incorporate a variety of pedestrian amenities to promote regular use. Pedestrian amenities may include, but are not limited to, seating, lighting, special paving, landscaping, food and flower vendors, artwork, and/or special urban recreational features.

Examples: Outdoor Gathering Spaces/Community Amenities

Following are examples of the types of outdoor gathering spaces/community amenities desired within the Downtown Mixed-Use District. These examples are provided for illustrative purposes only, all outdoor gathering spaces/community amenities shall be consistent with the regulations contained within this Chapter.

PATIOS AND PLAZAS:



PARKS AND SQUARES:



PROTECTED PEDESTRIAN WALKWAYS, ARCADES, RECESSED CORNER ENTRIES:



PUBLIC ART:



4. Buildings Adjacent to Outdoor Gathering Spaces/Community Amenities. To ensure the visibility and security of outdoor gathering spaces and community amenities, buildings located adjacent to an existing or planned pedestrian plaza, patio, or urban park shall provide at least two of the following elements along the building wall abutting the outdoor gathering space or community amenities:
 - a. A building entry;
 - b. Windows meeting the street frontage standards facing onto the outdoor amenity;
 - c. Arcades along the edges of the outdoor amenity;
 - d. Outdoor seating areas or cafes; or
 - e. A similar feature that the director finds will, to at least the equivalent degree; bolster security and encourage pedestrian use of the outdoor amenity.

5. Outdoor Decks and Balconies. Decks and balconies may project into the public right-of-way, over sidewalk areas, subject to the issuance of an encroachment permit.

6.6.5 Parking.

1. Intent.

- a. To encourage the redevelopment of smaller sites and the preservation and adaptive reuse of historic structures in downtown by providing a more flexible approach to parking;
- b. To minimize the visual and physical impact of surface parking lots on the downtown pedestrian environment;
- c. To reduce the predominance of single-purpose, surface parking lots in downtown; and
- d. To make efficient use of available on-street parking.

2. Minimum Required On-Site Parking.

Type of Use	Minimum # of on-site Parking Spaces Required
Residential Uses	
1 bedroom or studio unit	1 space/residential unit
2 bedroom unit	1.25 spaces/residential unit
3 or more bedroom unit	1.5 spaces/residential unit
Senior citizen housing	0.5 per bedroom plus 1 per employee for the largest shift.
Guest Parking	1 space per 8 dwelling units.
Commercial/Retail/Office Uses *	
Single use building (greater than 30,000 s.f.)	3 spaces per 1,000 square feet
Mixed-use building (greater than 30,000 s.f.)	2 spaces per 1,000 square feet
Single use building (5,000-30,000 s.f.)	2.75 spaces per 1,000 square feet
Mixed-use building (5,000-30,000 s.f.)	1.75 spaces per 1,000 square feet
Single use building (less than 5,000 s.f.)	2.5 spaces per 1,000 square feet
Mixed-use building (less than 5,000 s.f.)	1.5 spaces per 1,000 square feet
Existing building	No additional parking is required for a change of use in an existing building, even where the existing parking may be nonconforming. Additional parking must be provided in accordance with these standards for any building addition area that adds new habitable or leasable floor area. Amount of additional parking to be provided shall be calculated based upon new square footage only.

* In order to be eligible for minimum parking requirements outlined for mixed-use buildings, a maximum of 75-percent of a building's total square footage may be devoted to different uses within a single use group, as outlined in Section 6.5, Permitted Uses. This applies to any mixed-use buildings of any size.

3. Fee-In-Lieu. Applicants may make an in-lieu payment (as defined within the Carson City downtown parking strategy) for construction, maintenance and operation of public off-street parking or on-street parking instead of providing the full number of off-street parking spaces as required above. The portion of required parking eligible for an in-

lieu payment shall vary according to the type of use and the size of the development as follows:

Type of Use	Percentage of Required Off-street Parking spaces eligible for in-lieu payment
Residential Uses	
Guest Parking Only	Up to 25-percent
Commercial/Retail/Office Uses	
Single use building (greater than 30,000 s.f.)	Up to 15-percent
Mixed-use building (greater than 30,000 s.f.)	Up to 25-percent
Single use building (5,000-30,000 s.f.)	Up to 25-percent
Mixed-use building (5,000-30,000 s.f.)	Up to 50-percent
Single use building (less than 5,000 s.f.)	Up to 50-percent
Mixed-use building (less than 5,000 s.f.)	Up to 75-percent
Existing building	Up to 100-percent of additional parking required in conjunction with a building addition area that adds new habitable or leasable floor area.

4. **Shared Parking.** The amount of off-street parking required may be reduced by an amount determined through a parking demand study establishing that sufficient parking is or can be met by the subject uses through shared parking. The parking demand study shall provide information and evidence about the anticipated parking demand at peak times during the day and the distance relationship between available shared parking spaces and the specific uses served.
5. **Tandem Parking.** Required parking for residents of residential developments may be provided in the form of tandem parking when at least one space is within an enclosed garage or parking structure.

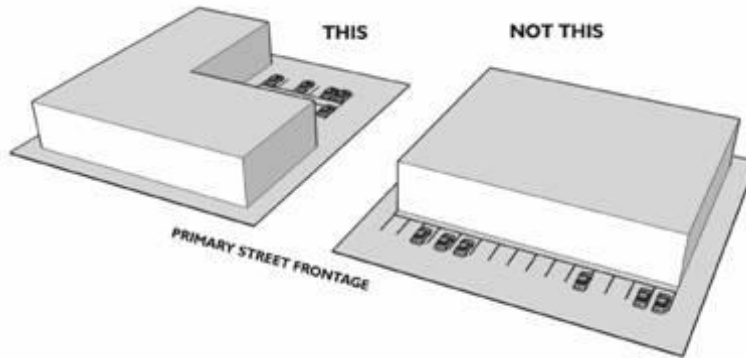

6. **Parking Location.** Surface parking shall be located behind and/or to the side of buildings. Surface parking will not be permitted between the building and the primary street frontage.

6.6.6 Landscaping and Screening.

1. Intent.
 - a. To create a more attractive, inviting, streetscape environment within downtown;
 - b. To reduce the visual prominence of surface parking within downtown; and

- c. To reinforce the more urban character of the downtown streetscape through the use of less space-intensive, structural screening methods.
2. Parking Lot Screening.
- a. All surface parking lots visible from the public right-of-way shall be screened using one of the following methods, unless otherwise noted in (c), below:
 - (1) A low masonry wall in combination with landscaping; or
 - (2) A wrought iron or other ornamental fence in combination with landscaping.
 - b. To satisfy the above standard:
 - (1) Landscaping shall be planted between the wall and the public right-of-way, sidewalk, or boundary; and
 - (2) Walls, fences, and landscaping shall not exceed 3.5 feet in height to adequately screen most car headlights while maintaining clear visibility into and out of the parking lot.
 - c. Developments of less than 10,000 square feet, or that involve the renovation of an existing building may use an ornamental fence or wall as a standalone screening mechanism to meet the surface parking screening requirement above to maximize available space.

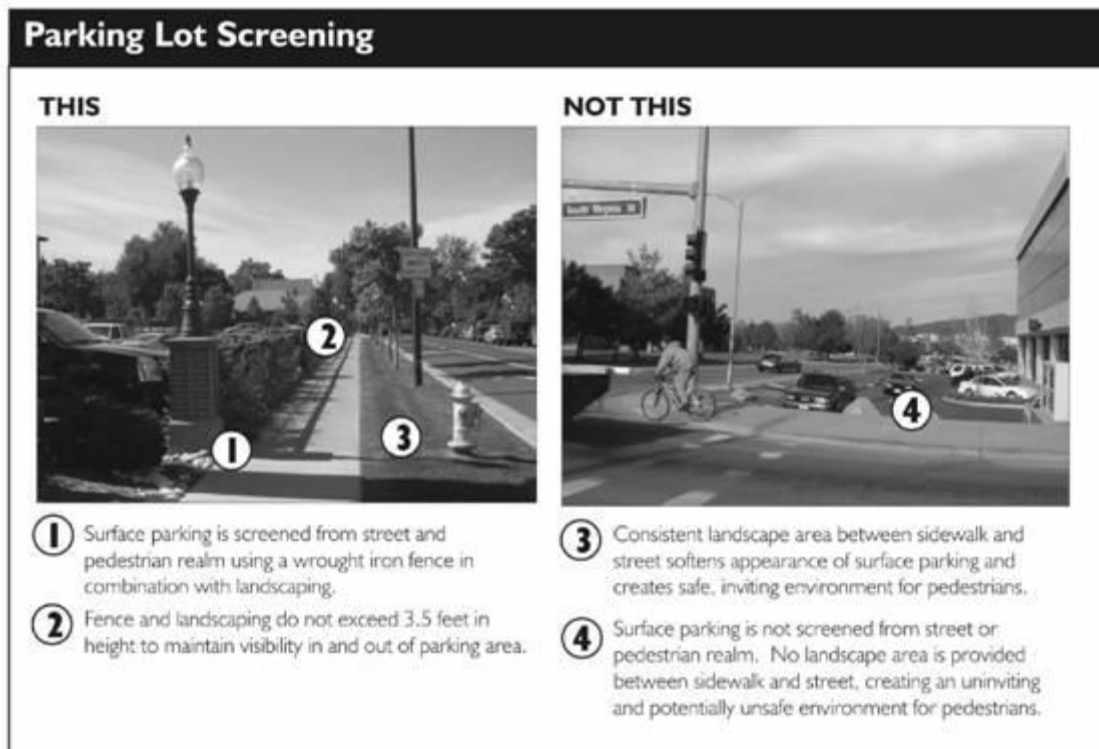

3. Trash Collection Areas.
- a. Trash enclosure area shall be provided or available to serve any new development or building expansion. Unscreened storage of trash receptacles is prohibited.

- b. Trash collection areas shall be screened from public rights-of-way and adjacent uses through the use of a 6-foot masonry wall enclosure and gate.
- c. Trash enclosures should be compatible with the architectural character of the building they serve and should incorporate similar materials and colors.

6.6.7 Streetscape.

1. Intent.
 - a. To create a safe, inviting streetscape environment for pedestrians in downtown;
 - b. To ensure that streetscape enhancements provided by infill and redevelopment projects are consistent with the city's downtown streetscape plan, and the surrounding development context, as applicable.
2. Downtown Streetscape Plan. Streetscape treatments (including street furniture) for all developments shall be provided in accordance with the city's downtown streetscape plan, as applicable.
3. Streetscape.
 - a. Prior to the completion of the city's downtown streetscape plan, and for all other properties not addressed within the completed downtown streetscape plan, streetscape shall be provided along all street frontages as follows:
 - (1). Residential Character: Minimum 5 foot-wide planter area in combination with minimum 8 foot sidewalk; or
 - (2) Urban Character: Minimum 15-foot sidewalk with street trees in grates.
 - b. Where angled, on-street parking currently exists or is specified within the city's downtown streetscape plan and the above configurations are not feasible, alternative streetscape configurations may be approved by the director.
 - c. Street furniture shall be placed so as to maintain a clear pedestrian walkway that is a minimum of 6 feet in width. Street furniture includes benches, trash receptacles, outdoor dining areas, and other pedestrian amenities.



4. Clear Zone. A clear zone of a minimum of 6-feet in width that is unobstructed by any permanent or nonpermanent street furniture, outdoor merchandise displays, benches, trash receptacles, outdoor dining areas, and other pedestrian amenities must be maintained.

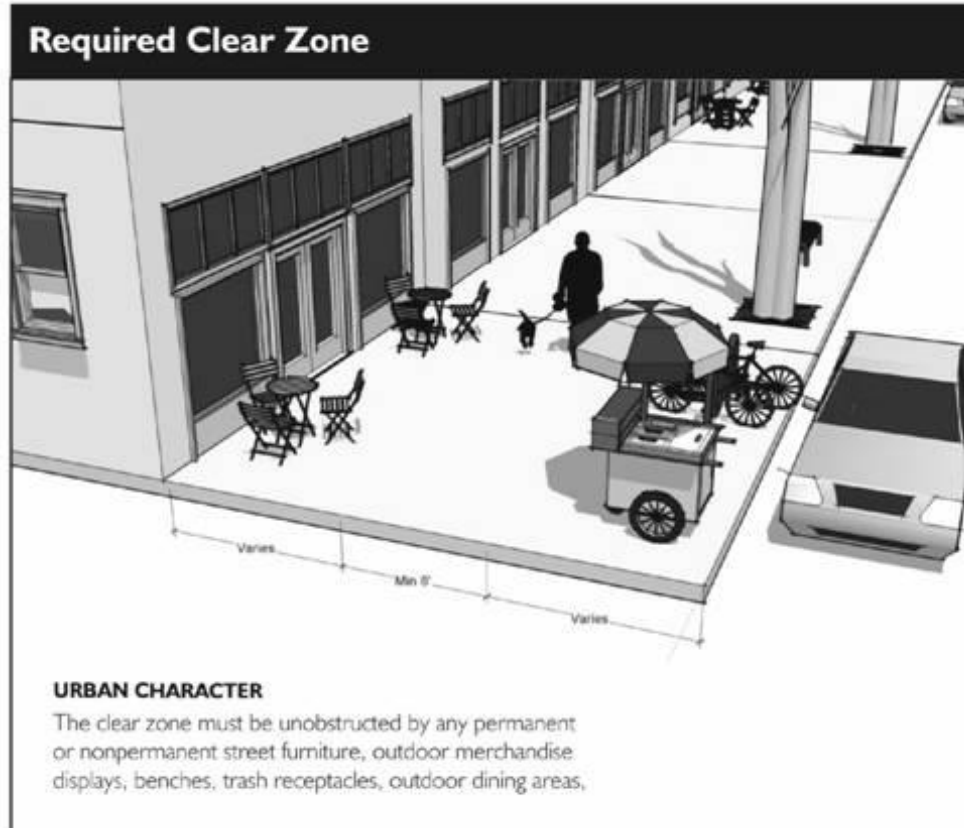

5. Outdoor Merchandise Displays.
- a. Each business shall be limited to one outdoor merchandise display. Outdoor merchandise displays may include:
 - (1) A single display table a maximum of 3 feet wide and 6 feet in length;
 - (2) A mannequin used to display clothing or other merchandise sold within the store;
 - (3) A grouping of furniture or other merchandise sold within the store that occupies a portion of the sidewalk not more than 3 feet in width and 6 feet in length; or
 - (4) Similar display as approved by the director.
 - b. Outdoor merchandise displays must be placed against the building the business operates from or within the landscaped area between the sidewalk and the street.
 - c. Outdoor merchandise displays shall be in compliance with clear zone provisions, as specified in subsection 6.6.7(4), of this section.
 - d. Outdoor merchandise displays shall not be displayed during non-business hours.

- e. No outdoor merchandise display shall be located where it obstructs the line of sight for passing motorists.

6.6.9 Street and Sidewalk Vending.

1. Intent.
 - a. To establish a set of baseline standards for the regulation of street vendor carts within downtown to ensure that they complement existing retail businesses, are compatible with the character of downtown, and expand the range of services available to downtown workers, visitors, and residents; and
 - b. To establish a framework for the long-term development of a formal street and sidewalk vending program to enliven the Downtown streetscape.
2. Vendor Carts. Street vendors are permitted in the DT-MU district only after approval by the redevelopment advisory citizens committee. Street vendors should have a positive impact upon the downtown, as determined by an evaluation of the application against all relevant provisions of this title. The following minimum standards shall apply for all such requests:
 - a. Street vendors shall be approved at a specific, permanent location;
 - b. Carts used for street vending shall be on wheels and shall not be larger than 3 feet by 5 feet;
 - c. Only consumable products may be sold from a street vendor cart;
 - d. If located within a city or State right-of-way, encroachment permits and liability insurance shall be required;
 - e. If adjacent to or in front of a business not their own, the street vendor cart operator shall be responsible for obtaining permission of the affected business and property owner and shall submit evidence of such permission;
 - f. If adjacent to or in front of a property listed in the Carson City historic district, review, approval, and compliance with conditions of the HRC shall be required;
 - g. Electrical and gas services require review and approval of the building and engineering divisions and the fire department;
 - h. Approval of the health department is required for all food vendors.
3. Vending Review Board. The redevelopment advisory citizens committee shall serve as the vending review board to review all applications for street vending.

6.6.10 Building Design and Character.

1. Intent.
 - a. Allow for the incorporation of a variety of architectural styles while ensuring that infill and redevelopment relates to the historic traditions of downtown Carson City and its surrounding neighborhoods in terms of its basic form, composition of building elements, and quality of materials;

- b. Establish a high quality appearance for downtown infill and redevelopment through the incorporation of architectural detailing, façade articulation, and other features designed to provide a more distinct character and pedestrian scale;
 - c. Ensure that infill and redevelopment contributes towards the vision set forth for downtown by the city's master plan.
2. Materials. Primary building materials shall be durable and project an image of permanence typical of downtown's traditional masonry storefronts and public buildings. Appropriate materials include, but are not limited to brick, stone, or other masonry products, steel, stucco, cast concrete, split face block, composite siding, or comparable material approved by the director.
3. Four-Sided Design.
- a. All building facades shall be designed with a similar level of design detail. Blank walls void of architectural detailing shall not be permitted.
 - b. Exceptions from the above standard may be granted for those areas of the building envelope that the applicant can demonstrate are not visible from adjacent development and streets.
 - c. Entrance locations should be placed with consideration of business-to-business pedestrian access and the relation to pedestrian crossings for safety.
4. Street Level Interest/Transparency.
- a. A minimum percentage of the total area of each ground floor building façade which faces a street, plaza, park, or other public space, shall be comprised of transparent window openings to allow views of interior spaces and merchandise, to enhance the safety of public spaces by providing direct visibility to the street, and to create a more inviting environment for pedestrians. Minimum percentages vary according to character area and use as follows:
 - (1) Main Street Mixed-Use Character Area: 50 percent minimum.
 - (2) Urban Mixed-Use Character Area:
 - (a) Non-Residential Uses: 50 percent minimum;
 - (b) Residential Uses: 35 percent minimum.
 - (3) Neighborhood Transition Character Area:
 - (a) Non-Residential Uses: 40 percent minimum;
 - (b) Residential Uses: 30 percent minimum.

Examples: Materials

Primary building materials shall be durable and project an image of permanence typical of Downtown's traditional masonry storefronts and public buildings. These examples are provided for illustrative purposes only. All materials shall be consistent with the regulations contained in this Chapter.



Street Level Interest/Transparency

NOT THIS



① Buildings that lack transparency do not create an inviting and interesting streetscape for pedestrians.

THIS



② Display windows provide transparency at the street level of these retail storefronts, creating an inviting environment for pedestrians.

Primary Building Entrances

Following are examples of building entrances made easily discernable through the use of architectural elements.



- b. For the purposes of the above standard, all percentages shall be measured using elevation views of the building plan and "ground floor" shall be measured from floor plate to floor plate.
- c. The following standards shall apply to all ground floor windows:
 - (1) Non-residential Uses. Glazing on all ground floor windows shall be transparent;
 - (2) Residential Uses. Glazing on ground floor windows shall be transparent to allow views into common hallways, foyers, or entryways, but may be translucent or opaque when necessary to protect the privacy of ground-floor spaces used for dwelling purposes;
 - (3) Black or mirrored glass is prohibited.
- 5. Primary Building Entrances. Primary building entrances shall be clearly distinguished through the use of one or more of the following architectural features:

- a. Covered walkways or arcades;
 - b. Awnings, canopies, or porches; and/or
 - c. Projected or recessed building mass.
6. Parking Structures.
- a. Facades of single-use parking structures (e.g., no retail or residential) shall be articulated through the use of 3 or more of the following architectural features;
 - (1) Windows or window shaped openings;
 - (2) Masonry columns;
 - (3) Decorative wall insets or projections;
 - (4) Awnings;
 - (5) Changes in color or texture of materials;
 - (6) Approved public art;
 - (7) Integrated landscape planters; or
 - (8) Other features as approved by the director or designee.
 - b. Openings in parking structures shall be designed to screen views of parked cars from surrounding properties through the use of architectural screens or similar features.
7. Residential Garage Location and Design.
- a. Where lot configurations permit, residential garages shall be located in the rear yard and accessed from the alley or a narrow drive from the street, as traditionally found in downtown's residential neighborhoods.
 - b. Attached front-loading garages shall be recessed behind the front façade of the home a minimum of 10 feet.
8. Screening of Utility/Mechanical Equipment.
- a. Roof mounted mechanical equipment shall be screened from public rights-of-way and adjacent properties through the use of parapet walls, equipment wells, architectural screens, or similar features that may be integrated into the overall design of the building.
 - b. All equipment shall be located below the highest vertical element of the building.
 - c. Wall-mounted air conditioning units shall be integrated into the design of the building and/or screened.
- 6.6.11 Guidelines for the Renovation and Restoration of Existing Structures.
- 1. Intent.
 - a. To promote the preservation of existing downtown buildings that have historic characteristics, although they are not included as part of the historic district.

- b. To promote and establish appropriate procedures for the cleaning, renovation, and restoration of original downtown storefronts that have been substantially altered and obscured during previous remodeling efforts.
2. Inappropriate Alterations.
- a. Remodeling with unauthentic false historical details, trims, and moldings creates a confusing historical context for the community and should be avoided.
 - b. The use of light gauge metal, steel panels, or other materials to make two or more storefronts appear to be a single, larger structure should be avoided. If panels are already in place, upper story windows, storefronts, doors, cornices, and other trim materials which were removed to accommodate the panels should be researched and replaced during the rehabilitation process.
 - c. Upper story doors and windows and street-level storefronts that have been previously covered, sealed, or filled in should be restored to their original proportions and appearance during the rehabilitation process.
 - d. Transom windows which were covered over when suspended acoustical tiled ceilings were installed, or for other reasons, should be uncovered during the rehabilitation process.

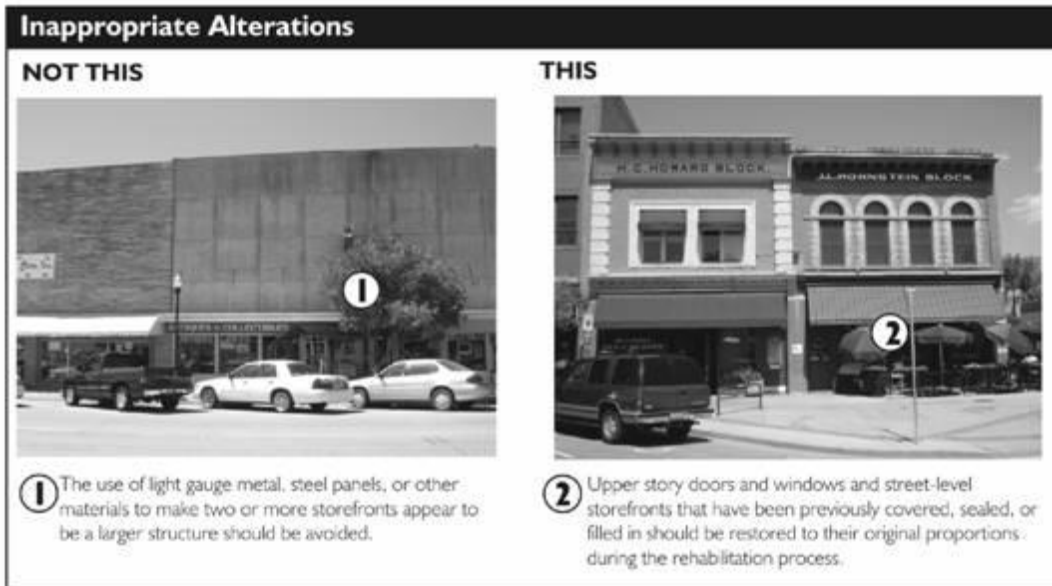

3. Cleaning.
- a. Abrasive cleaning techniques such as sandblasting should be avoided on the exterior of downtown buildings. Such cleaning methods cut into the building's materials, causing irreversible damage.
 - b. Sandblasted buildings that have not severely deteriorated should be painted to slow the process. Care must be taken to avoid varnishes, enamels, polyurethane sealants and other products impervious to moisture penetration. Sealants will lock moisture inside the masonry and prevent evaporation ultimately causing severe moisture damage.

- c. As an alternative to abrasive cleaning techniques, the following techniques should be considered:
 - (1) A gentle water wash in combination with a natural bristle brush used to gently scrub the surface of the building. If necessary, a mild detergent can be used, but must be thoroughly rinsed.
 - (a) For heavy grime or layers of paint, a chemical cleaner may be necessary. Alkaline or acidic cleaners are available; however, chemical cleaning should always be done by experienced professionals.
 - (b) A steam cleaning process may also be appropriate for certain building materials.
 - d. Whether water, steam, or chemical cleaner is used, always clean a test patch area first to judge the reaction, or consult a professional in the field. A list of local professionals is available at the planning division.
 - e. All debris and cleaning materials should be contained on site and not allowed to flow into the storm drain system.
4. Repair, Removal, and Replacement.
- a. Removal of materials or structures including oversized signs, windows or door coverings, or metal slipcovers should not take place until the following steps are followed:
 - (1) Inventory and photograph or draw accurate elevations of the elements to be removed;
 - (2) Examine each element and determine how it is attached and anchored to the building. If possible, remove a small portion of a slipcover to determine how the rest is anchored;
 - (3) Create a plan for repair of original material that was damaged when alterations were made; drilled holes for anchor bolts, lost or damaged decorative elements, accumulated dirt and rust stains are the most common types of damage.
 - b. If a decorative element such as a cornice or trim around a window was removed or altered to accommodate earlier renovation efforts, it may require replication by a skilled artisan or replacement with a simpler element. Catalogs of companies that specialize in replicating historic building architectural details are available from the planning division.
 - c. If the original element is lost and no photo documentation is present, it is recommended that the element be substituted with a more conservative design element.
 - d. Materials used to renovate existing buildings should be of a texture, scale, and color that are compatible with the original primary building material. Replacement parts should be selected so as to blend in with existing ones; rather than calling attention to themselves.

- e. Native stone and masonry should be retained on existing buildings when possible.
- f. Missing or damaged architectural features that are to be replaced should blend with the building fabric and duplicate the old or match it as closely as possible. However, these new materials should not be antiqued or made to look old when they are not.
- g. Retention of original historic building elements is encouraged over replacement. When replacement is required, attention should be given to matching the building's original window treatment as closely as possible.

SECTION XXXX:

That Title 18 Appendix (CARSON CITY DEVELOPMENT STANDARDS), Division 6 (DOWNTOWN MIXED-USE DISTRICT), Section 6.7 (Building envelope standards) is hereby amended (**bold, underlined** text is added, [~~stricken~~] text is deleted) as follows:

6.7 Building envelope standards.

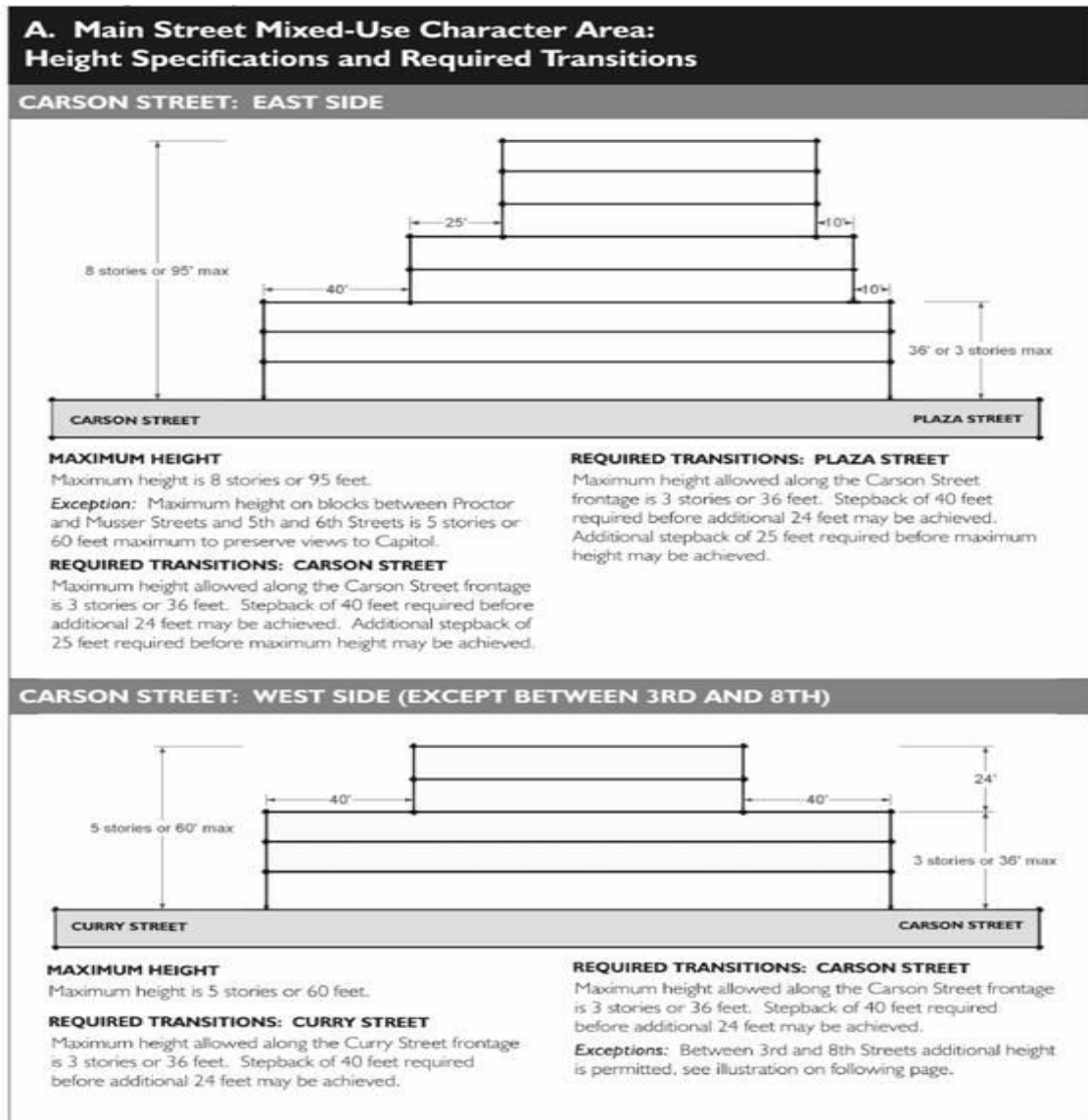

A. Main Street Mixed-Use Character Area: Height Specifications and Required Transitions

CARSON STREET: BETWEEN 3RD AND 8TH

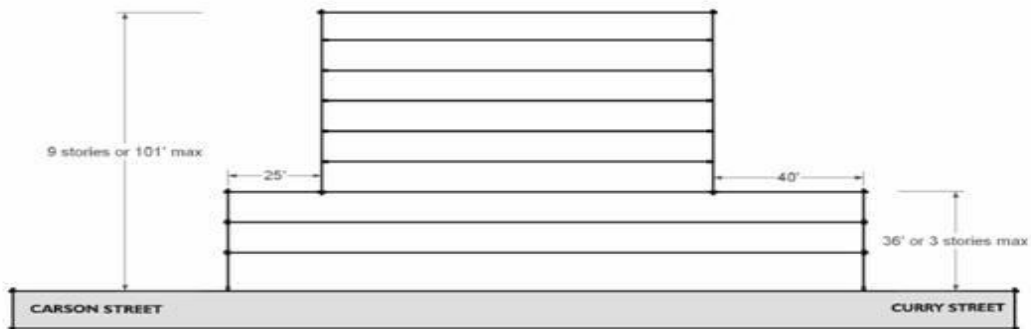

MAXIMUM HEIGHT

Maximum height is 9 stories or 101 feet.

REQUIRED TRANSITIONS: CARSON STREET

Maximum height allowed along the Carson Street frontage is 3 stories or 36 feet. Stepback of 25' feet required before maximum height may be achieved.

REQUIRED TRANSITIONS: PLAZA STREET

Maximum height allowed along the Carson Street frontage is 3 stories or 36 feet. Stepback of 40 feet required before maximum height may be achieved.

ALL EAST/WEST STREETS:

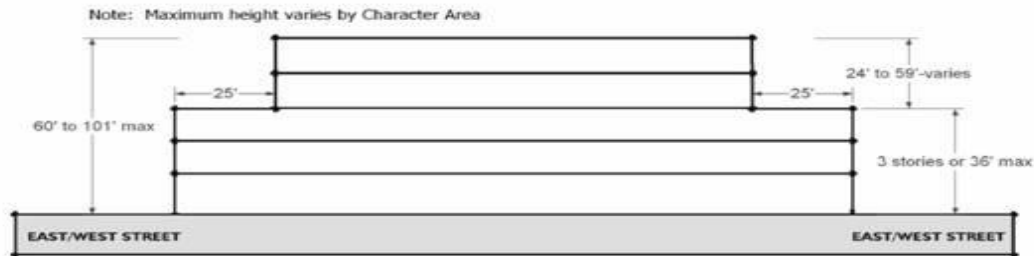

Note: Maximum height varies by Character Area

MAXIMUM HEIGHT

Between 60 and 101 feet depending upon Character Area.

Exception: Maximum height on blocks east of Carson Street and between Proctor and Musser Streets or 5th and 6th Streets is 5 stories or 60 feet maximum to preserve views to Capitol.

REQUIRED TRANSITIONS: ALL EAST/WEST STREETS

Maximum height allowed along the Carson Street frontage is 3 stories or 36 feet. Stepback of 25 feet required before maximum height may be achieved.

B. Urban Mixed-Use Character Area: Height Specifications and Required Transitions

PLAZA STREET

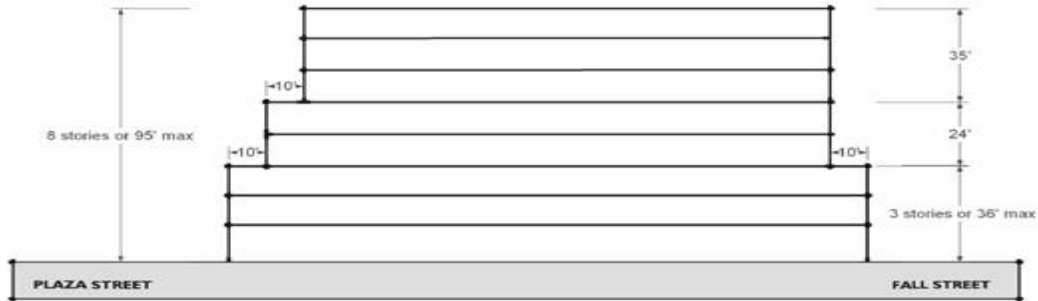

MAXIMUM HEIGHT

Maximum height is 8 stories or 95 feet.

Exception: Maximum height on blocks between Proctor and Musser Streets and 5th and 6th Streets is 5 stories or 60 feet maximum to preserve views to Capitol.

REQUIRED TRANSITIONS: FALL STREET

Maximum height allowed along the Fall Street frontage is 3 stories or 36 feet. Stepback of 10 feet required before maximum height may be achieved.

REQUIRED TRANSITIONS: PLAZA STREET

Maximum height allowed along the Plaza Street frontage is 3 stories or 36 feet. Stepback of 25 feet required before additional 24 feet may be achieved. Additional stepback of 10 feet required before maximum height may be achieved.

ALL EAST/WEST STREETS

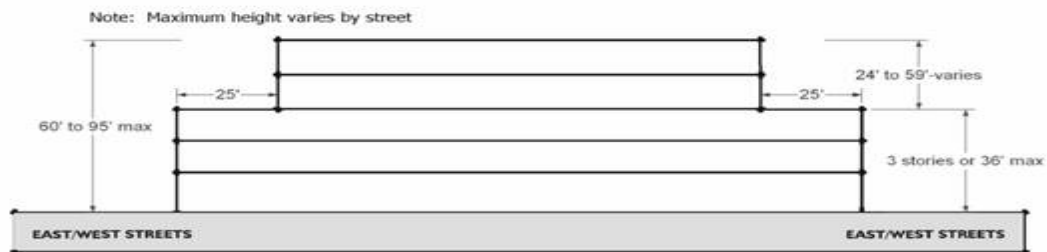

MAXIMUM HEIGHT

Maximum height is 8 stories or 95 feet.

Exception: Maximum height on blocks between Proctor and Musser Streets and 5th and 6th Streets is 5 stories or 60 feet maximum to preserve views to Capitol.

REQUIRED TRANSITIONS: EAST/WEST STREETS

Maximum height allowed along all east/west street frontages is 3 stories or 36 feet. Stepback of 25 feet required before maximum height may be achieved.

B. Urban Mixed-Use Character Area: Height Specifications and Required Transitions

STEWART STREET

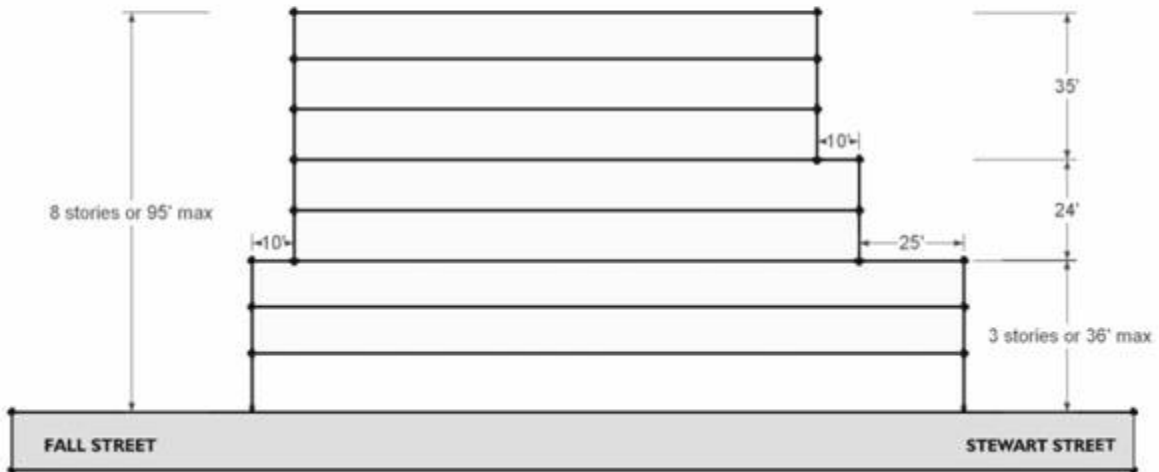

MAXIMUM HEIGHT

Maximum height is 8 stories or 95 feet.

Exception: Maximum height on blocks between Proctor and Musser Streets and 5th and 6th Streets is 5 stories or 60 feet maximum to preserve views to Capitol.

REQUIRED TRANSITIONS: FALL STREET

Maximum height allowed along the Fall Street frontage is 3 stories or 36 feet. Stepback of 10 feet required before maximum height may be achieved.

REQUIRED TRANSITIONS: STEWART STREET

Maximum height allowed along the Stewart Street frontage is 3 stories or 36 feet. Stepback of 10 feet required before additional 24 feet may be achieved. Additional stepback of 10 feet required before maximum height may be achieved.

C. Neighborhood Transition Character Area: Height Specifications and Required Transitions

CURRY STREET 2ND ST TO JOHN ST

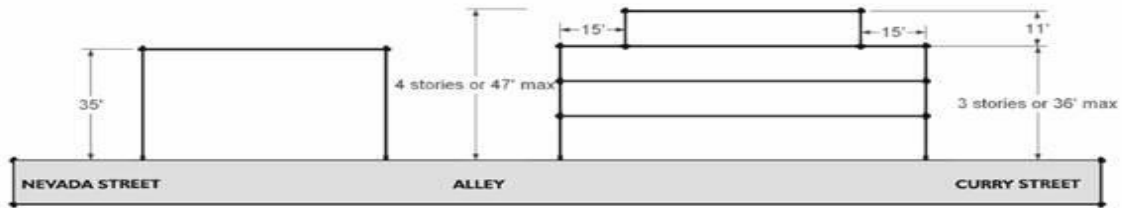

MAXIMUM HEIGHT

Maximum height is 4 stories or 47 feet.

REQUIRED TRANSITIONS: ALLEY

Maximum height allowed along the alley is 3 stories or 36 feet. Stepback of 15 feet required before maximum height may be achieved.

REQUIRED TRANSITIONS: CURRY STREET

Maximum height allowed along the Curry Street frontage is 3 stories or 36 feet. Stepback of 15 feet required before maximum height may be achieved.

CURRY STREET: 2ND ST TO 9TH ST

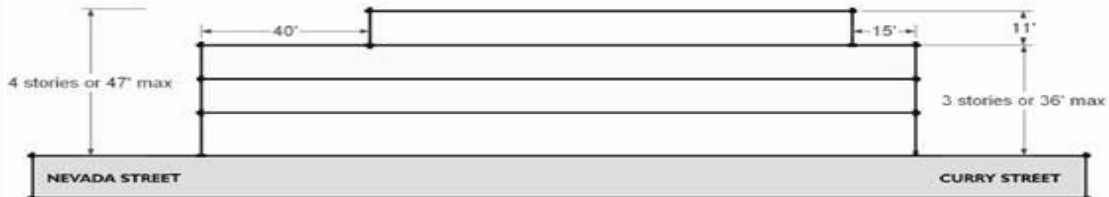

MAXIMUM HEIGHT

Maximum height is 4 stories or 47 feet.

REQUIRED TRANSITIONS: NEVADA STREET

Maximum height allowed along Nevada Street frontage is 3 stories or 36 feet. Stepback of 40 feet required before maximum height may be achieved.

REQUIRED TRANSITIONS: CURRY STREET

Maximum height allowed along Curry Street frontage is 3 stories or 36 feet. Stepback of 15 feet required before maximum height may be achieved.

C. Neighborhood Transition Character Area: Height Specifications and Required Transitions

STEWART STREET: MUSSER ST TO WASHINGTON ST

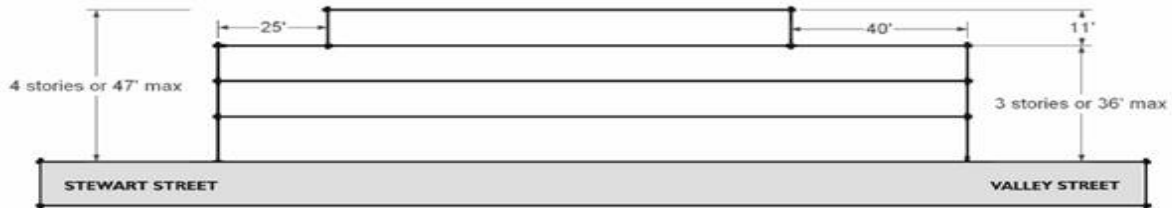

MAXIMUM HEIGHT

Maximum height is 4 stories or 47 feet.

REQUIRED TRANSITIONS: STEWART STREET

Maximum height allowed along the Fall Street frontage is 3 stories or 36 feet. Stepback of 25 feet required before maximum height may be achieved.

REQUIRED TRANSITIONS: VALLEY STREET

Maximum height allowed along the Valley Street frontage is 3 stories or 36 feet. Stepback of 40 feet required before maximum height may be achieved.

ALL EAST/WEST STREETS

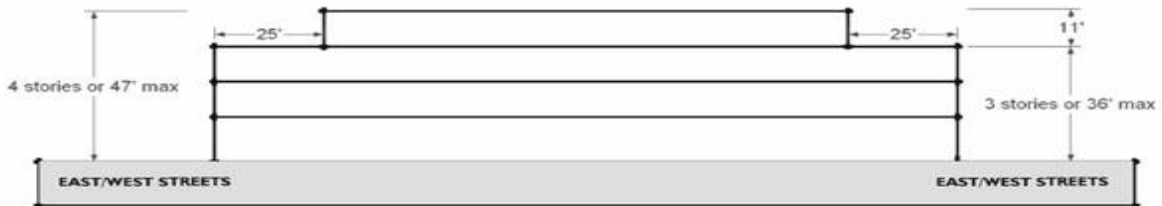

MAXIMUM HEIGHT

Maximum height is 4 stories or 47 feet.

REQUIRED TRANSITIONS: EAST/WEST STREETS

Maximum height allowed along all east/west street frontages is 3 stories or 36 feet. Stepback of 25 feet required before maximum height may be achieved.

D. Site Layout/Building Orientation

MAIN STREET MIXED-USE AND URBAN MIXED-USE

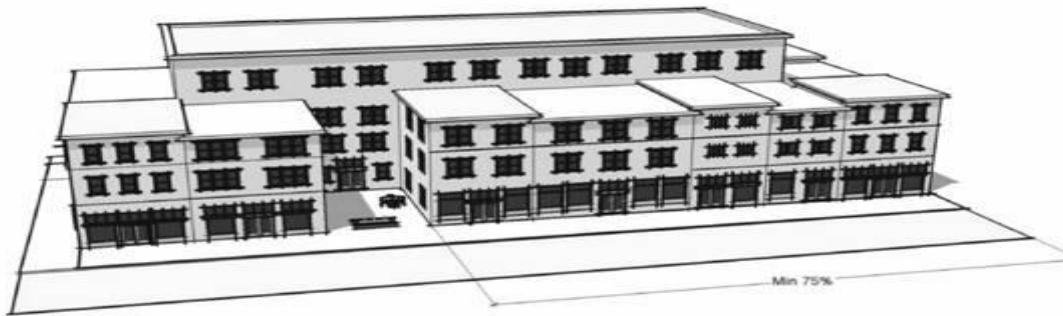

MINIMUM STREET FRONTAGE

A minimum of 75% of the building wall must be built to within 10 feet of the property line. Excludes public areas designated as outdoor gathering space.

SIDE/REAR SETBACK

None required.

MAXIMUM LOT COVERAGE

None.

NEIGHBORHOOD TRANSITION



SETBACKS

None required, except where infill development occurs adjacent to historic structure, in which case, contextual setbacks shall be utilized.

MAXIMUM LOT COVERAGE

70 percent.

SECTION XXXX:

That Title 18 Appendix (CARSON CITY DEVELOPMENT STANDARDS), Division 6 (DOWNTOWN MIXED-USE DISTRICT), Section 6.8 (Building types) is hereby amended (**bold, underlined** text is added, [~~stricken~~] text is deleted) as follows:

6.8 Building types.

6.8.1 Applicability. Building types desired within the downtown mixed-use district can be organized into four categories based upon their scale and distinctive characteristics (e.g., urban vs. residential). One or more of the four categories of building types is permitted within each character area, as noted below. Building types are intended to be conceptual

only—they do not constitute a specific design and are intended to be applied within the context of the general development standards and guidelines and the building envelope standards contained in this division. Building types are illustrated on the pages that follow.

6.8.2 Building Type

Building Type	Applicable Character Area
A: Single Unit/Residential Character	Neighborhood Transition
B: Two or more units/Residential Character	Downtown Mixed-Use; Urban Mixed-Use; Neighborhood Transition
C: Multi-Unit/Urban Residential Character	Downtown Mixed-Use; Urban Mixed-Use
D: Mixed-Use Urban Character	Downtown Mixed-Use; Urban Mixed-Use

Building Type: A
SINGLE UNIT/RESIDENTIAL CHARACTER

The diagrams illustrate the building type through three perspectives: 1. **BUILDING MASSING/Form**: A perspective view of four houses with gabled roofs, showing 'Existing Home' and 'Infill Development' between them. 2. **STREETSCAPE CHARACTER**: A perspective view from the street showing the houses with trees and cars. 3. **REAR YARD W/ALLEY ACCESS**: A perspective view from the rear showing an alleyway and parking areas.

Characteristics

BUILDING MASSING/Form
 Scale and massing of individual buildings is consistent with the residential character of the surrounding neighborhood context.

STREETSCAPE CHARACTER

- Homes separated through use of a side setback.
- Building entrances oriented to the primary street frontage.

REAR YARD W/ALLEY ACCESS
 Parking accommodated in enclosed garages, on-street, and/or in surface lots behind structures.

RELATIONSHIP TO THE STREET

- Broad front yard setback.
- Sidewalk separated from street by planting area and regularly spaced street trees.

Building Type: B

TWO OR MORE UNITS/RESIDENTIAL CHARACTER

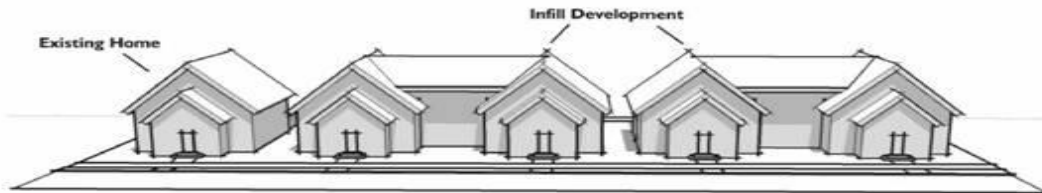

BUILDING MASSING/FORM



STREETSCAPE CHARACTER



REAR YARD W/ALLEY ACCESS

Characteristics

BUILDING MASSING/FORM

Scale and massing of multi-unit buildings designed to appear as a large single-family home when viewed from the street, allowing for the incorporation of a variety of housing types and compatible non-residential uses while protecting the residential character of the neighborhood.

STREETSCAPE CHARACTER

- Side setback maintained to preserve single-family character of the neighborhood.
- Building entrances oriented to the primary street frontage or a central courtyard.

REAR YARD

Parking accommodated in enclosed garages, on-street, and/or in surface lots behind structures (office or live/work use).



RELATIONSHIP TO THE STREET

- Broad front yard setback.
- Sidewalk separated from street by a planting area and regularly spaced street trees.

Building Type: C

MULTI-UNIT/URBAN RESIDENTIAL CHARACTER



BUILDING MASSING/FORM



STREETScape CHARACTER

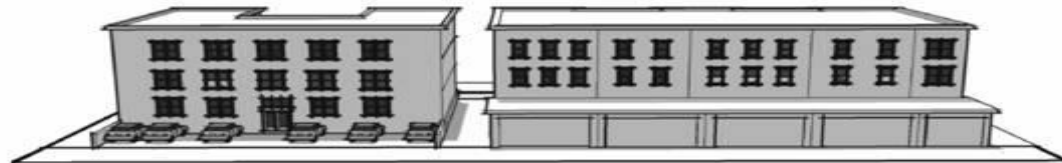

REAR YARD W/ALLEY ACCESS

Characteristics

BUILDING MASSING/FORM

Buildings are typically more blocky and urban in form than those in the Neighborhood Transition Character Area.

STREETScape CHARACTER

- Front facade is built to the back of streetscape edge, except where outdoor gathering spaces/community amenities are provided.
- Buildings are built to side lot lines in most cases, although setbacks may be appropriate when providing transitions to a surrounding neighborhood or to an existing historic structure.
- Building entrances oriented to the primary street frontage or a central courtyard.

REAR YARD W/ALLEY ACCESS

Parking accommodated in enclosed garages, on-street, and/or in surface lots behind structures.



RELATIONSHIP TO THE STREET

- Entrances are typically raised above the sidewalk level.
- Sidewalk is wide to accommodate pedestrian traffic and street furniture.
- Street trees placed in grates or surrounded by planting areas.



SECTION XXXX:

That Title 18 Appendix (CARSON CITY DEVELOPMENT STANDARDS), Division 7 (HILLSIDE DEVELOPMENT), Section 7.1 (Purpose) is hereby amended (**bold, underlined** text is added, [~~stricken~~] text is deleted) as follows:

7.1 Purpose.

The purpose of this section is to provide standards and requirements for new and expanded development on hills and slopes, as defined in this section, in such a manner that the public health, safety, welfare, and resources of Carson City are protected. The standards and requirements of this section are designed to minimize the potential of hillside development that

could cause or contribute to landslides, erosion, sedimentation, deforestation, flooding and/or the aesthetic degradation of the city's natural environment. This section is to be used in conjunction with the provisions of Appendix J, Chapter 18, of the Building Code as currently adopted by Carson City and Section 18.08 (Hillside Development) of the Carson City Municipal Code (CCMC). Where there are no minimum requirements or standards prescribed by this section, the existing provisions of Title 17 (Subdivisions) Title 18 (Zoning Ordinance) or the development standards shall dictate the standards and practices to be followed. ~~[This division is administered by development engineering services.]~~ **The Development Engineering Division of the Department shall administer the provisions of this Division.**

SECTION XXXX:

That Title 18 Appendix (CARSON CITY DEVELOPMENT STANDARDS), Division 7 (HILLSIDE DEVELOPMENT), Section 7.2 (Applicability) is hereby amended (**bold, underlined** text is added, ~~[stricken]~~ text is deleted) as follows:

7.2 Applicability.

7.2.1 Any parcels or development sites exhibiting an average 15% slope or more are subject to the standards and requirements of this section.

7.2.2 The following formula shall be used to determine average slope for hillside standards: $S = I \div D \times 100$; where S is average slope; where I is the difference between the highest and lowest contour lines of a topographical map for the parcel, in feet; and D is the distance between the contour lines used in computing I, in feet; and 100 is the conversion factor into percentage. The average slope of a parcel is measured along a line located near the center of any area to be used for development.

7.2.3 "D" must be perpendicular to the height contours.

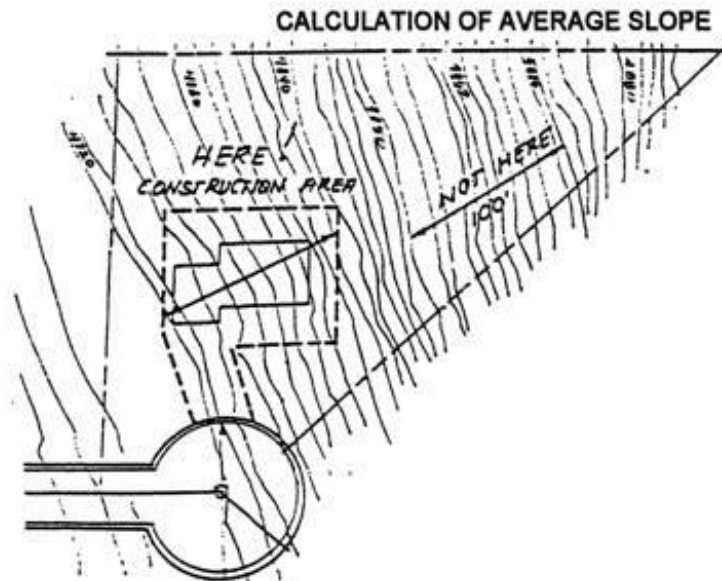

SECTION XXXX:

That Title 18 Appendix (CARSON CITY DEVELOPMENT STANDARDS), Division 7 (HILLSIDE DEVELOPMENT), Section 7.3 (Engineering reports and requirements) is hereby amended (**bold, underlined** text is added, [~~stricken~~] text is deleted) as follows:

7.3 Engineering reports and requirements.

7.3.1 Professional Project Engineer Responsibilities.

- a. It is the responsibility of the project engineer to prepare a grading plan; to incorporate into the grading plan all recommendations contained in the soils, geology, and hydrology reports that may be required by the building department; to inspect and certify all grading operations; and to certify that the work was completed in accordance with the approved grading plans upon the completion of the project.
- b. Prior to and during grading operations, all necessary reports, compaction data, soils, geology and hydrology recommendations must be submitted by the project engineer to the building department.
- c. The project engineer must make an immediate written report, with recommended corrective measures to the building department, if the engineer discovers that the work on a hillside is below the standards required by this ordinance or by the approved final grading plan.
- d. If the project engineer, soils engineer, geologist, or hydrologist of record ceases his or her professional services on a hillside project, the grading work must be halted until the replacement engineer has agreed to accept the responsibility for certification of the work.
- e. Upon completion of all development related to the development of a single parcel and prior to issuance of a certificate of occupancy, the project engineer shall certify to the building department that all work was performed in accordance with approved plans.
- f. The [~~city engineer~~] **City Engineer** may approve procedures for securing financial instruments in order to secure improvements not completed prior to occupation.

7.3.2 Drainage.

- a. Curb, gutter, and pavement design must [~~insure~~] **ensure** that water on roadways is prevented from flowing off the roadway in an uncontrolled fashion.
- b. Natural drainage-ways must be riprapped or otherwise stabilized below drainage and culvert discharge points for a distance sufficient to convey the discharge without channel erosion.
- c. Waste material from construction, including soil and other solid materials, may be deposited within the 100 year floodplain, only after strict compliance with the

provisions of Title 12 of the flood protection ordinance of the Carson City Municipal Code.

- d. The overall drainage system must be completed and made operational at the earliest possible time during construction.
- e. Alterations of Federal Emergency Management Agency (FEMA) defined flood-ways are prohibited except in accordance with the provisions of Title 12 of the Carson City Municipal Code.

7.3.3 Grading Plans.

- a. A grading plan which complies with this section and Appendix J, Chapter 18, of the Building Code as currently adopted by Carson City, must be prepared by a professional engineer and submitted with development applications. (Note: Chapter 18 of the Building Code as currently adopted by Carson City, provides a nationally accepted method of regulating grading activities, including procedures, fee schedules, and accepted engineering practices for hillside development.)
- b. Development on slopes in excess of 33% or more, as determined by the provisions of this section, shall be strongly discouraged and will require a special use permit. The special use permit process allows the consideration of these sites on a case-by-case basis, providing for a mechanism in which a development proposal must be justified prior to approval.
- c. Material necessary for filling purposes must come from a source permitted under an approved grading plan or as permitted by the extraction operation of the Carson City Municipal Code Title 18, Section 18.14.
- d. A re-vegetation and slope stabilization plan, as defined in 7.3.4 of this section, must be submitted with the grading plan.
- e. Cuts and fills must be rounded off in order to avoid the appearance of scarring.

7.3.4 Vegetation and Re-vegetation.

- a. Applicants shall submit a slope stabilization and re-vegetation plan that includes the following information:
 - 1. A complete description of the existing vegetation;
 - 2. The vegetation to be removed and the method of disposal;
 - 3. The vegetation to be planted;
 - 4. Slope stabilization measures to be installed; and
 - 5. A time frame for proposed actions.
- b. The re-vegetation and slope stabilization plan must be submitted with the grading plan.
- c. Vegetation may be removed only when absolutely necessary.
- d. Every effort shall be made to conserve topsoil removed during construction for later use on areas requiring vegetation or landscaping, e.g., cut and fill slopes.

- e. ~~[Vegetation]~~ **Live vegetation** sufficient to stabilize the soil must be established on all disturbed areas as each stage of grading is completed. Areas not contained within lot boundaries must be protected with adapted fire resistant species of perennial vegetal cover after all construction is completed.
- f. The applicant is fully responsible for any destruction of native vegetation identified in the plans for retention. The applicant carries the responsibility of employees and all subcontractors for the protection of native vegetation from the first day of construction until the certificate of occupancy is issued.
- g. Every effort shall be made to use fire-resistant plants in revegetation. Such plants generally grow close to the ground, have a low sap or resin content, grow without accumulating dead branches, needles or leaves, are easily maintained and pruned, and are usually drought-tolerant.
- h. Seed that is used for re-vegetation must be comprised, by total weight to be used, of not less than 25 percent of seeds that are identified in by the City as pollinator-friendly. Unless deferral is necessary for successful planting, seeding should occur during the seasonal timeframes that are typically recommended by the Natural Resources Conservation Service of the United States Department of Agriculture, currently established as late autumn before the onset of the winter season. Any fill or hay or straw to be used that is not a native species must be certified weed-free. Best management practices must be implemented to minimize erosion and sediment transport during any construction or restoration activity. Water, wood or other weed-free fiber, and a tackifier, must be added to seed to ensure complete coverage of any area that is selected for hydroseeding.**

7.3.5 Topographic Mapping.

- a. A topographic map of the area proposed for development shall be submitted.
- b. The topographic map must:
 1. Include the surrounding area within 20 feet of the proposed project site;
 2. Be drawn to a standard engineering scale with a minimum contour interval of 5 feet;
 3. Illustrate drainage areas subject to inundation by the 10 year flood as identified by FEMA, or, identification of the 100 year flood for drainage not previously mapped by FEMA;
 4. Identification of rock outcroppings;
 5. Identification of skyline areas for the purpose of this section; and
 6. Identification of geologic faults and/or areas subject to any other geologic hazard.

7.3.6 Driveways and Parking.

- a. Combinations of collective private driveways, clustered parking areas, and on-street parallel parking bays are encouraged, provided they meet applicable fire department standards, to optimize the objectives of minimum soil disturbance, minimum impervious cover, excellence of design, and aesthetic sensitivity.

- b. Collective private driveways serving a maximum of 6 single family parcels are encouraged where their use will result in better building sites and less land coverage than would result if a public road were required.
- c. U-shaped driveways are encouraged to increase access and fire protection.
- d. The maximum slope on any driveway portion shall be 12%.
- e. The minimum width of a driveway shall be 12 feet.
- f. A driveway must be provided to a structure when access, as defined by the Fire Code as currently adopted by Carson City, is more than 150 feet from any exterior portion of the building.
- g. All driveways must be made of an all weather surface and must have a minimum vertical clearance of 13 feet, 6 inches.
- h. Driveways in excess of 150 feet in length must have turnarounds with an inside turning radius of not less than 30 feet and an outside radius of not less than 45 feet. Driveways in excess of 200 feet must be provided with turnouts at least 10 feet wide and 30 feet long. Driveway turnouts must be located as required by the Fire Chief.

7.3.7 Utilities.

- a. All new permanent service utilities, both on-site and off-site, must be placed underground.

SECTION XXXX:

That Title 18 Appendix (CARSON CITY DEVELOPMENT STANDARDS), Division 7 (HILLSIDE DEVELOPMENT), Section 7.4 (Buildable area) is hereby amended (**bold, underlined** text is added, [~~stricken~~] text is deleted) as follows:

7.4 Buildable area.

- 7.4.1 No development is permitted which significantly increases hazards of avalanche, rock fall landslide, flooding, or soil erosion.
- 7.4.2 The proposed building site, including driveway pads, shall be situated to keep environmental degradation and fire hazards to a minimum.
- 7.4.3 The disturbance of the existing hillside landscape shall be minimized by:
 - a. Retaining trees and natural vegetation to the greatest extent possible while allowing for the required 30 foot defensible space;
 - b. Providing a minimum of cuts and fills and earth grading;
 - c. Blending graded areas with undisturbed natural terrain through the design of graded slopes;

- d. Minimizing the amount of exposed raw earth at any time in the project by careful phasing of the stages of construction;
- e. Requiring immediate replanting of areas disturbed by construction;
- f. Reducing the proposed depth of cuts and fills on hillsides to the greatest extent possible;
- g. Every effort should be taken in order to design foundations that step with the slope rather than flattening a site in order to create a pad.

SECTION XXXX:

That Title 18 Appendix (CARSON CITY DEVELOPMENT STANDARDS), Division 7 (HILLSIDE DEVELOPMENT), Section 7.5 (Open space) is hereby amended (**bold, underlined** text is added, [~~stricken~~] text is deleted) as follows

7.5 Open space.

- 7.5.1 It shall be strongly encouraged to preserve and/or protect rugged and steeply sloping terrain associated with slopes of 33% or more as undisturbed open space.
- 7.5.2 Open space areas and easements shall be placed in continuity with other surrounding open space areas in order to maximize the opportunity for the creation of trails and recreation areas.
- 7.5.3 The scenic quality of hillsides shall be protected by:
 - a. Preserving local natural landmarks such as rock outcrops or canyons,
 - b. Preserving the cover of native vegetation as much as possible,
 - c. Intensive replanting to hide or obscure manmade development, and
 - d. By preserving natural drainage channels with devices, fixtures, swales, and retention areas to bring storm run-off into conformance with existing standards.

SECTION XXXX:

That Title 18 Appendix (CARSON CITY DEVELOPMENT STANDARDS), Division 7 (HILLSIDE DEVELOPMENT), Section 7.6 (Fire protection) is hereby amended (**bold, underlined** text is added, [~~stricken~~] text is deleted) as follows:

7.6 Fire protection.

- 7.6.1 Lot size and potential placement of structures shall be such that adequate clearance of hazardous, flammable vegetative cover may be accomplished.

- 7.6.2 All easements for firebreaks for safety of built-up areas shall encompass access for fire fighting personnel and equipment and such easements shall be dedicated for this specific purpose by being recorded.
- 7.6.3 All hillside development plans must provide for fire safety to reduce the spread of wildfire and reduce opportunity of ignition by:
- a. Providing fire lanes, fuel breaks, and non-combustible roofs and building materials,
 - b. Use of spark arresters,
 - c. Clearing of underbrush and excess vegetation near dwellings and by use of fire resistant local plant species.
- 7.6.4 Addresses and street name signs must be clearly visible and well posted. Use of at least four-inch high letters and/or numbers is strongly encouraged.
- 7.6.5 No structure may be located more than one thousand (1,000) feet from a water supply as measured along an unobstructed line of vehicular travel.
- 7.6.6 The use of non-treated wood shingles shall not be allowed as roofing materials in hillside areas.
- 7.6.7 In addition to the standards and requirements set forth above regarding fire protection, all development in hillside areas must comply with the most current guidelines related to prevention of wildfires in hillside areas as required by the Carson City Fire Department.

SECTION XXXX:

That Title 18 Appendix (CARSON CITY DEVELOPMENT STANDARDS), Division 7 (HILLSIDE DEVELOPMENT), Section 7.7 (Maintenance) is hereby amended (**bold, underlined** text is added, [~~stricken~~] text is deleted) as follows:

7.7 Maintenance.

- 7.7.1 The owner of any private property on which grading or other work has been performed pursuant to a grading plan approved or a building permit granted under the provision of this chapter must continuously maintain and repair all graded surfaces and erosion prevention devices, retaining walls, drainage structures or means, and other protective devices, plantings, and ground cover installed or completed.

SECTION XXXX:

That Title 18 Appendix (CARSON CITY DEVELOPMENT STANDARDS), Division 7 (HILLSIDE DEVELOPMENT), Section 7.8 (Additional requirements for parcel maps and subdivision maps) is hereby amended (**bold, underlined** text is added, [~~stricken~~] text is deleted) as follows:

7.8 Additional requirements for parcel maps and subdivision maps.

- 7.8.1 The following formula must be used to determine the average slope of land to be subdivided by subdivision map or parcel map: $S = (0.0023)(I)(L) \div A$ where: S = Average percent slope, I = Contour interval in feet, L = Summation of length of contours in scale feet, A = Area in acres of parcel being considered.
- 7.8.2 Before any parcel map or tentative subdivision map is approved where a portion of which has an average slope of 15% or greater as defined in this section, the following requirements must be met.
- a. A slope analysis map indicating the average slopes on the parcel must be submitted.

The slope analysis map is intended to provide the means to visually convey that the flatter portion of a parcel is being proposed for development of homes and the steeper portions remain open. The slope analysis map must indicate average slope by the following categories:

 1. Areas of 15 to 19.9%,
 2. Areas of 20 to 24.99%,
 3. Areas of 25 to 33.99%, and
 4. Areas of 33% or more.
 - b. The proposed development must comply with the standards for drainage improvements, driveways and parking, slope stabilization, re-vegetation, placement of utilities, buildable area standards, open space, setbacks, grading, roadway design, construction standards, pedestrian facility provisions, access, height of structure, fire protection and maintenance of improvements as contained in this section.
 - c. Every lot of a subdivision or parcel map must comply with the requirements of Section 18.08.
- 7.8.3 When designing subdivisions, there shall be a consideration of a reduced height limit on downslope lots fronting collector streets in order to provide unobstructed views of lower panoramic areas to be accomplished by requiring a maximum height of 15 to 20 feet at the property setback line.
- 7.8.4 In addition to the provisions of Title 17 and Title 18 of the Carson City Development Code, Carson City shall not approve a parcel map, or subdivision where the fire line water pressure is insufficient to the standards adopted by Carson City.
- 7.8.5 Provide infrastructure to rural standards rather than urban standards, as much as feasible, without reducing safety or performance for vehicular and pedestrian circulation and for drainage and storm run-off.
- 7.8.6 Provide legal and financial mechanisms that assure future maintenance, repair, and replacement of hillside infrastructure whose cost is usually more expensive than similar facilities provided in conventional flatland development; and that assure areas set aside in subdivisions as permanent, undeveloped open space.

SECTION XXXX:

That Title 18 Appendix (CARSON CITY DEVELOPMENT STANDARDS), Division 7 (HILLSIDE DEVELOPMENT), Section 7.9 (Roadways) is hereby amended (**bold, underlined** text is added, [~~stricken~~] text is deleted) as follows:

7.9 Roadways.

- 7.9.1 No grading, filling, clearing, or excavation of any kind is permitted until the final roadway grading plan is formally approved by the [~~city engineer.~~] **City Engineer.**
- 7.9.2 Fill areas must be prepared by removing organic material, such as vegetation and rubbish and any other material which is determined by the soils engineer to be detrimental to proper compaction or otherwise not conducive to stability.
- 7.9.3 All retaining walls or facings with a total vertical projection in excess of three feet (3') and associated with cut or fill surfaces shall be designed as structural members keyed into stable foundations and capable of sustaining the design loads.
- 7.9.4 Borrowing for fill is prohibited unless the material is obtained from a cut permitted under an approved grading plan, or imported from areas outside within Carson City; or subject to Title 18.
- 7.9.5 Roads must be designed to create the minimum feasible amount of land coverage and the minimum feasible disturbance to the soil.
- 7.9.6 Road alignment should follow natural terrain and no unnecessary cuts or fills are allowed in order to create additional lots or building sites.
- 7.9.7 Variations by [~~city engineer.~~] **the City Engineer** in right-of-way standards are permitted to prevent the dedication of unnecessarily large parcels of land in accordance with the building department ordinance.
- 7.9.8 Variations by [~~city engineer.~~] **the City Engineer** in road design and road construction are permitted in order to keep grading and cut-fill slopes to a minimum.
- 7.9.9 Roads in excess of two (2) travel lanes are not allowed. The width of two-lane roads must not exceed thirty-two feet (32') and must have a minimum width of twenty-six feet (26').
- 7.9.10 One-way streets are permitted and encouraged where appropriate for the terrain and where public safety would not be jeopardized. The travel way must not exceed twenty feet (20') in width and may have curbs and sidewalks on one (1) side only.
- 7.9.11 The width of the graded section must extend three feet (3') beyond the curb back or edge of pavement on both the cut and fill sides of the roadway. If sidewalks are to be installed parallel to the roadway, width of the graded section shall be increased by the width of the sidewalk plus one foot (1') beyond the curb back.
- 7.9.12 No roads are permitted on natural slopes in excess of fifteen percent (15%).
- 7.9.13 Cul-de-sacs shall be designed with a minimum radius [~~of forty five feet (45').~~] **as may be required by the International Fire Code, as adopted by the City.**

- 7.9.14 The cross-slope of roads shall not exceed two percent (2%).
- 7.9.15 Two (2) roadway accesses must be provided in and out of developed areas.
- 7.9.16 Provide a buildable dwelling site on each lot by identifying a sufficiently sized and relatively level building area with enough stability and bearing capacity of geologic structures and soils to support a principal building, positioned on the lot, to be reasonably accessible from public streets.

SECTION XXXX:

That Title 18 Appendix (CARSON CITY DEVELOPMENT STANDARDS), Division 7 (HILLSIDE DEVELOPMENT), Section 7.10 (Setbacks) is hereby amended (**bold, underlined** text is added, [~~stricken~~] text is deleted) as follows:

7.10 Setbacks.

- 7.10.1 A thirty foot (30') defensible space setback shall be required as set forth in this section.
- 7.10.2 Accessory structures are not encouraged within the required setbacks.
- 7.10.3 Homes built at the top of a slope need a minimum setback of one hundred feet (100') from the edge of the slope with an additional thirty feet (30') for defensible space.

SECTION XXXX:

That Title 18 Appendix (CARSON CITY DEVELOPMENT STANDARDS), Division 7 (HILLSIDE DEVELOPMENT), Section 7.2 (Applicability) is hereby amended (**bold, underlined** text is added, [~~stricken~~] text is deleted) as follows:

SECTION XXXX:

That Title 18 Appendix (CARSON CITY DEVELOPMENT STANDARDS), Division 7 (HILLSIDE DEVELOPMENT), Section 7.11 (Severability) is hereby repealed (**bold, underlined** text is added, [~~stricken~~] text is deleted) as follows:

7.11 [Severability.

~~If any one or more of the sections, subsections, clauses, or provisions of this ordinance, or the application thereof to any circumstances, shall for any reason be held to be unconstitutional or invalid, such unconstitutionality or invalidity shall not affect any other sections or provisions of this ordinance.]~~ **Repealed.**

SECTION XXXX:

That Title 18 Appendix (CARSON CITY DEVELOPMENT STANDARDS), Division 8 (PARK STANDARDS), Section 8.1 (Purpose) is hereby amended (**bold, underlined** text is added, [~~stricken~~] text is deleted) as follows:

8.1 Purpose.

The following park standards have been prepared to provide quality design and long term maintenance of public park areas within the city. The standards are to [~~insure~~] **ensure** that facilities are planned and designed within parameters which are safe, are of a lasting quality, creates an enjoyable environment, and provides for ease of maintenance.

The Carson City parks and recreation master plan element provides policy direction for providing park facilities within the community, and defines the types of facilities (standards) as mini-park, linear park/trails, neighborhood park, community park, special use park, and conservancy area.

As new development occurs within the community, the current residential construction tax generates revenue for installation of facilities within existing parks or in some instances new parks. In order for new park facilities to be added within the city, the recreational purpose of the facility must serve a broad spectrum of users within the city or neighborhood.

SECTION XXXX:

That Title 18 Appendix (CARSON CITY DEVELOPMENT STANDARDS), Division 8 (PARK STANDARDS), Section 8.2 (Relationship to other plans) is hereby amended (**bold, underlined** text is added, [~~stricken~~] text is deleted) as follows:

8.2 Relationship to other plans.

The following documents provide various forms of direction relating to future Carson City park locations, size and type of recreational facilities:

- a. Carson City parks and recreation master plan element;
- b. Carson River master plan;
- c. Carson City transportation plan;
 1. Bicycle element;
 2. Pedestrian element;
- d. [~~Carson City eagle valley trail system plan;~~] **Unified Pathways Master Plan element;**
and
- e. Carson City open space element to the master plan.

These documents provide information relative to future trails, pathways, trailheads, and other specialty issues which require the below development standards.

SECTION XXXX:

That Title 18 Appendix (CARSON CITY DEVELOPMENT STANDARDS), Division 8 (PARK STANDARDS), Section 8.3 (Park design principles) is hereby amended (**bold, underlined** text is added, [~~stricken~~] text is deleted) as follows:

8.3 Park design principles.

In order to provide park facilities which are attractive, enjoyable, safe and functional, the following principles are encouraged to be utilized for park design.

- 8.3.1 Park design should seek to create a distinctive site character, provide creative design solutions, in context with its surroundings, and establish a setting that encourages neighborhood interaction and safety.
- 8.3.2 Scale and proportion of all park elements should be compatible and promote unity in overall park design.
- 8.3.3 Spatial areas should be designed to provide for a sense of relaxation, or dynamic action, or delight/enjoyment/calm, etc., through spatial modulation, sequence, and the harmonious relationship of design elements.
- 8.3.4 Design of play areas for children should promote curiosity, wonder, challenge, fun, safety, shelter and should provide for different age groups.
- 8.3.5 Human scale and visual detail should be used to stimulate enduring use of the park.
- 8.3.6 Entry design elements should provide a sense of arrival and useful visual cues for the visitor.
- 8.3.7 Park design should weigh the use of shelter/gazebo/amphitheater as focal architectural elements or visual landmarks.
- 8.3.8 Park design should enhance pedestrian and bicycle access/arrival, with automobile conflicts minimized
- 8.3.9 Choice and placement of plant materials should satisfy:
 - a. Environmental conditions (soil, water, climate, sun/wind exposure);
 - b. Cultural conditions (evocative impressions and images);
 - c. Functional conditions (durable, maintenance, longevity, conservation);
 - d. Aesthetic conditions (tree shape quality; soft, airy, bold, majestic).
- 8.3.10 Plant material color, texture, form, scale, and grouping should be used creatively to provide focus, interest, shade, windbreaks, spatial creation, and a perceptible character to the park and its features.

- 8.3.11 Pathways should be multi-use and designed in relation to their function; paths should guide and encourage appropriate movement and minimize conflict of User groups.

SECTION XXXX:

That Title 18 Appendix (CARSON CITY DEVELOPMENT STANDARDS), Division 8 (PARK STANDARDS), Section 8.4 (Specific design elements) is hereby amended (**bold, underlined** text is added, [~~stricken~~] text is deleted) as follows:

8.4 Specific design elements.

In designing park facilities, specific design elements shall be considered and included in the site programming aspects of the project. These design elements correctly incorporated into the park site design promote the health, safety and welfare of the public, encourage appropriate recreational uses, provide for proper access while minimizing automobile/pedestrian conflicts, allow for law enforcement surveillance, and enhance the aesthetic values of a community.

8.4.1 Access.

- a. On-street parking is preferred for neighborhood parks to allow for the greatest park use area.
- b. Bicycle racks and automobile parking facilities shall be provided as part of the design program.
- c. Americans With Disabilities Act (ADA) requirements shall be incorporated into the park design.

8.4.2 Circulation.

- a. Circulation conflicts between pedestrians, bicycles, and automobile shall be minimized/mitigated.
- b. Main walkways shall be minimum 6 feet wide.
- c. Walkways with alternate maintenance vehicle access shall be minimum 8 feet wide, and designed for load.
- d. Multi-use paths with various user groups demands shall be 12 feet wide, and constructed to meet American Association of State Highways and Transportation Officials (AASHTO) standards. In rare instances, the city may reduce the path widths to meet AASHTO minimum standards.

8.4.3 Play Zones.

- a. Play/activity areas shall be designed for the appropriate age and activity levels.
- b. Play spaces for children shall provide an appropriate mix of play types: challenges, enclosure, a natural experience, and the appropriate space, and surfacing for each.

8.4.4 Site Drainage.

- a. Natural patterns of a site shall be incorporated into the design of facilities, when appropriate.
 1. Surface flow is preferred over culverted flow to minimize maintenance.
 2. Primary use areas shall have positive drainage to an appropriate collector.
 3. Turf fields shall have a 1.5% slope to provide positive surface drainage.

8.4.5 Landforms.

- a. Landforms that create a varied park and recreational experience in concert with the design intent of the park shall be implemented.
- b. Park design shall work with the landform and accentuate positive site features.
- c. Berms shall be a maximum of 3:1.

8.4.6 Landscape Character.

- a. The design of the park shall provide for coherence and quality in the use of plant materials (trees, shrubs, groundcover, etc.) and retain valuable trees and vegetation, where appropriate.
- b. The use of trees in the design shall provide for a recognizable landscape character; formal/informal, rustic/urban, riparian/upland, etc.; and consider seasonal appearance; use of large-scale trees where appropriate shall be included as part of the design.
- c. Parks shall have a predominant deciduous tree cover and grouping to provide for mitigation of climate extremes and seasonal winds. (Minimum mature deciduous canopy coverage of 33%.)
- d. Parks shall incorporate the aspect of art features within the context of the park design.

8.4.7 Spatial Organization.

- a. The design shall incorporate the elements of spatial organization: appropriate area, form, enclosure, containment, grouping, and transition for the various levels of activity, and experience intended for the park.

8.4.8 Visual Elements.

- a. The design shall incorporate visual techniques such as screening, sequence, enhancement of appropriate visual elements; and create a sense of drama, interest, and exploration, as appropriate.
- b. Artistic/sculptural/focal elements can be an ingredient of good park design.
- c. Color, texture, and form shall reinforce overall design of park.

8.4.9 Energy/Water Conservation. The principles of energy conservation site planning shall be evident in the design of the park; including solar access, wind mitigation, conservation of soil and water, energy efficiency, and pedestrian/bicycle accessibility.

- a. The 7 principles of Xeriscape landscaping shall be considered and incorporated into the park landscape areas:
 - 1. Xeriscape principles:
 - Planning & design;
 - Soil analysis & improvements;
 - Practical turf areas;
 - Appropriate plant selection;
 - Efficient irrigation;
 - Mulching;
 - Appropriate maintenance.
- 8.4.10 Quality of Materials/Construction.
- a. Materials and products shall be of a durable, attractive, appropriate, and consistent quality throughout.
 - b. To ensure durable park facilities, Building Codes as currently adopted by Carson City, standard specifications for public works and the park standard details and specifications shall be minimum standards of construction.
 - c. Certain materials/products shall be designated as standardized park components. (See Standard Park Components, Division 8.6.)
 - d. Plant materials shall be hardy for the northern Nevada climate, of high quality, and meet American Nurseryman's Association Standards, at minimum.
- 8.4.11 Lighting.
- a. Lighting shall serve both functional and aesthetic considerations, and be energy efficient.
 - b. Lighting shall provide appropriate illumination for secure evening use of facilities, discourage vandalism, and enhance the visual ambience of the park, and shall not spill over on to adjacent properties or create glare skyward.
 - c. Luminaries shall be appropriate in size, color, material and scale to the setting, provide cut-off control of illumination, and visually reinforce the design style of the park.
- 8.4.12 Maintenance/Vandalism.
- a. Long-term maintenance shall be a clear design consideration, while not impeding innovative and interesting park design.
 - b. Principles of defensible space shall be apparent in the design.
 - c. Materials that are durable, modular, and vandal-resistant shall be given appropriate consideration.
 - d. Surveillance of targeted elements by the neighborhood and park ranger shall be considered in park design development.

8.4.13 [Special Parks. Regional storm water drainage facility/detention basin parks

- a. ~~Detention basins shall be designed for park use early in the development process. (Review by park staff, development services engineering staff, and park design consultants shall occur early in design.)~~
- b. ~~Basin parks should provide out-of-flood areas for structures, recreational equipment, and support elements not favorable to basin flooding.~~
- c. ~~Basin parks shall be designed to contain nuisance flows in defined channels or areas.~~
- d. ~~Urban run-off can be hazardous; basin inlet/outlets shall protect basin park users. (Warning signs indicating the quality/depth of run-off is appropriate.)~~
- e. ~~Basin soils shall be tested to indicate probable time to dry after inundation, and/or depth to groundwater.~~
- f. ~~Basin parks shall have a naturalistic/attractive contouring of basin with a 6:1 slope; steeper slopes may be allowed with exemplary design contouring.~~
- g. ~~Basin parks with limited recreational utility shall be given proportional residential construction tax (RCT) credit.~~
- h. ~~A range of plant materials that sustain short-term inundation shall be considered in the design of the basin-wetted area.~~

8.4.14] Linear Parks.

- a. Linear parks shall have sufficient width to buffer adjacent land-use, provide space for trees, rest areas, and an enjoyable outdoor mobile experience.
- b. Linear park walkways are not to be considered on-street bike lane substitutes. Multi-use paths are to be 12 feet in width.
- c. Lighting for evening walking and security are an essential consideration.
- d. Walkway adjacent to roadways should be separated from road by a minimum 5 feet wide planting zone.
- e. Turf area should be minimized; other living groundcover preferred.
- f. Curb ramps along the primary travel path shall have a standard 5 feet bottom width. Curb ramps and sidewalk shall be arranged to provide for auto/pedestrian safety and visibility at intersections/crossings.
- g. Curb ramps shall use 1 removable bollard (minimum 4 feet on center, maximum 5 feet on center) to inhibit vehicle access, when appropriate.

SECTION XXXX:

That Title 18 Appendix (CARSON CITY DEVELOPMENT STANDARDS), Division 8 (PARK STANDARDS), Section 8.5 (Park plan development process) is hereby amended (**bold, underlined** text is added, [~~stricken~~] text is deleted) as follows:

8.5 Park plan development process.

The typical design process for a park shall follow the sequence outlined below:

- 8.5.1 Program Development. This element establishes goals and objectives for development of the park facility. Who are the users, how will the facility be integrated with the recreation activities anticipated, what is the expected user experience, what is the budget, etc. This element is developed in consultation with park staff.
- 8.5.2 Site Analysis. This element starts with inventory of on-site and off-site factors, including both man-made elements and natural resources. Man-made elements include legal and physical boundary improvements such as buildings, roads and utilities, land uses, etc. Natural resources include topography, soil and geologic conditions, water, vegetation, wildlife, etc. Natural forces include temperature, sand, wind, precipitation, etc. Perceptual characteristics include views, smells, spatial patterns, general impressions, etc. Seek to identify the special nature of the site; this is also known as the opportunities and constraints phase.
- 8.5.3 Conceptual Diagrams. This element starts by grouping program items into logical associations so that their interdependence can be understood. This element is generally referred to as the "bubble diagram" stage. It concentrates on functional relationships and lines of travel without regard to scale or detailed site information. Next, opportunities and constraints of the site are factored in so that uses can be located where they make the most sense.
- 8.5.4 Review. After development of the site analysis and conceptual diagrams, review by the park staff must be accomplished by the city prior to schematic design.
- 8.5.5 Schematic Design. Once program relationships and on-site and off-site factors are understood, the diagram is translated into a loosely-scaled sketch. The bubble diagrams should be viewed as just guidelines that can be freely manipulated to accommodate a great idea. This is the stage where ideas flow freely in design charrettes; all factors will be reacted to simultaneously as the concepts take shape. It is important to develop several alternative designs for staff review.
- 8.5.6 Review. Presentation to the park and recreation commission for approval is held at this juncture to [~~insure city~~] **ensure City** input has been incorporated and selection in final design solution for the park facility.
- 8.5.7 Design Development. Also referred to as the master plan, this phase is characterized by a carefully rendered plan of the selected alternative, usually accompanied by character sketches, elevations and blow-up plans of key areas. It is important to have all elements scaled carefully at this phase so that there will be no surprises after the plans are reviewed and approved by the city. Usually there is an

emphasis on graphic impact as the plans will be used for agency presentations and/or public display. A key component of this stage is a detailed cost estimate; this will be reviewed carefully by the city and will impact what facilities can be included in the park.

8.5.8 Review and Approval. The parks and recreation commission and the board will review the plans for final approval.

8.5.9 Construction Documents. These are the detailed plans and specifications for the park construction and will include various professional disciplines for a design such as the landscape architect, civil engineer, architect, and electrical engineer. These plans must be completed in the manner described in the landscape standards section of the appendix of this document. Park staff will review and approve the final construction documents before submitting to the Carson City building department for a city building permit.

8.5.10 Bidding and Construction. Depending on the type of facility, project budget and scope of work, the city will put the project out for formal competitive bids following the procedures required by the city.

8.5.11 Project Close Out. At the completion of the project, the city will require all construction documents to be provided to the city in electronic and hard copy format.

8.6 Standard park components.

To allow for efficiency in maintenance and repair, materials inventory, training of personnel, and recognizing the need of consistently attractive and durable products, certain park facility products, materials, and elements are standard components of park facility products, materials, and elements. Contact the [~~parks and recreation department~~] **Department of Parks, Recreation and Open Space** for the required standard components for park facility products, materials and elements regarding any future park construction projects.

SECTION XXXX:

That Title 18 Appendix (CARSON CITY DEVELOPMENT STANDARDS), Division 9 (TRAIL STANDARDS), (Design guidelines) is hereby amended (**bold, underlined** text is added, [~~striken~~] text is deleted) as follows:

9.05 Design guidelines.

The following guidelines are set forth to implement [~~Carson City's trail standards.~~] **Carson City trail standards.** (References: Carson City [~~parks and recreation~~] **Parks and Recreation** master plan element, Carson City transportation plan-bicycle [~~element, Carson River master plan and Carson City Eagle Valley trail system.~~]) **and Unified Pathways Master Plan).**

For additional details about horizontal alignment, sight distances, signing and marking, drainage, intersections, pavement structure, **crossings** and grade-separation structures for paved bicycle paths refer to the Guide for the Development of Bicycle Facilities prepared by the

American Association of State Highway and Transportation Officials (AASHTO) Task Force on Geometric Design.

Similarly, for trails on federal lands, refer to the trail construction guidelines of the U.S. Forest Service and the Bureau of Land Management.

[Generally speaking,] **In general,** Carson City trails are intended to be designed for multi-use and available for all types of general public users. [These] **In general, these** trails will be nonmotorized, except for [city] **City** maintenance vehicles, and provide off-road routes of travel that serve both recreational and transportation functions. Most trails are intended for only day-use passive recreational activities. **Off-highway vehicles may only be operated in designated areas. Wherever feasible, trails should be designed to provide access for persons with disabilities.**

SECTION XXXX:

That Title 18 Appendix (CARSON CITY DEVELOPMENT STANDARDS), Division 9 (TRAIL STANDARDS), Section 9.1 (Trails) is hereby amended (**bold, underlined** text is added, [~~stricken~~] text is deleted) as follows:

9.1 Trails.

9.1.1 Trail Design. [~~Figures 1 through 6 illustrate the design~~] **Design** characteristics for Carson [City's] **City** trail **and trailhead** standards [~~within the Eagle Valley trail system, Carson River master plan,~~] **are set forth in the Unified Pathways Master Plan** and the regional transportation plan-bicycle element. Refer to these documents to determine which trail **and trailhead** design is applicable to a particular trail **and trailhead** segment.

9.1.2 [~~Trails and Land Use Compatibility. Trails will be located along property lines where feasible or located in conjunction with the use of the lands as identified in any new proposals for land use changes.~~]

Trails **that are not located** within planned road rights-of-way should be set back from occupied dwellings a minimum distance in accordance with Table [~~A:~~] **A, as set forth in this section.** Where setbacks specified in Table A are not feasible, potential noise and privacy impacts must be evaluated and reduced by use of berms, fencing, landscaping and other feasible and compatible means, if necessary.

**Table A
Trail Setback Guidelines**

Land Use Category*	Trail Setback Guidelines from Occupied Dwelling
(HDR) High Density Residential	25 feet
(MDR) Medium Density Residential	25 feet
(LDR) Low Density Residential] Single-family 1 Acre (SF1A)	50 feet
(SR) Suburban Residential	100 feet
(RR) Rural Residential] Single-family 5 acre (SF5A)	100 feet

(AR) Agricultural/Residential	300 feet
[(OSR) Open Space/ Recreational/ Rural Residential] Public (P)	300 feet

* As defined by the land use element of the Carson City master plan.

~~[In areas where trail routes are adjacent to private property, fencing should be used if requested by the adjacent property owner to deter users from leaving the trail. Several types of fencing could be used; for example, 4 smooth strand wire, a wire mesh fence with wood corner posts/metal tee posts, split rail wood fence or chain link fence and should be of a uniform nature for any given trail segment. Fencing should be selected in cooperation with the adjacent property owner(s).~~

~~9.1.3—Road Crossings. At grade road crossings must be designed to equally consider vehicular and trail user safety (reference: Figure 7). Road crossings should be designed at road intersections and are preferred at these locations for safety reasons. If design constraints require a mid-block road crossing, a center refuge island with crosswalk striping should be considered to minimize pedestrian/vehicle conflicts and user safety.~~

~~9.1.4—Sight Distance. Clearing widths of shared use trails involving bicycles and pedestrians should be designed to meet AASHTO standards to assure proper sight distance where possible. If sight distances on curves, around hills or through densely vegetated areas are less than one hundred feet (100'), safety signs and reduced speed limits should be considered. At the intersections of shared use trails or where off-road bicycle trails intersect with on-road bicycle routes not at road intersections, there should ideally be a fifteen foot (15') turning radius and twenty five foot (25') sight clearance between the two (2) trail routes.~~

~~9.1.5—Trail Under Crossings. Where a trail must pass under a highway bridge, sufficient vertical clear space and security lighting should be provided to accommodate trail use. Where practical, the design should provide an optimum horizontal dimensions as called for by AASHTO standards. Where the provision of such spaces is not possible, alternative pavement textures should be provided and safety signs placed on either side of the under crossing involved to inform trail users of such conditions and the procedures to follow, such as reducing speeds or dismounting.~~

~~9.1.6—Trail Structures.~~

~~9.1.6.1—Drainage Crossings. Trails crossing creeks and drainages may require a culvert. Culverts in water courses or drainages must be carefully placed to minimize disturbance. Erosion control measures must be taken to prevent erosion at the outfalls of drainage structures. The fill over culverts should match the trail and shoulder width.~~

~~9.1.6.2—Trail Bridges. Bridges should be a minimum of five feet (5') wide on single track trails and a minimum of eight feet (8') wide on a natural surfaced shared use trail. Bridges for paved shared use trails should be a minimum of ten feet (10') wide and structurally capable of carrying maintenance vehicles, if required. All bridges must have minimum forty two inch (42") high railings when necessary. Bridge footings should be constructed outside of the stream's top of bank.~~

~~9.1.7—Access and Safety Barriers. (Reference: Figures 7 and 8)~~

~~Bollards, boulders, logs, stiles, and/or other structures should be used to prevent motorized vehicles of the public from entering trail routes at any crossing of a public road right of way or at any trail staging area.~~

~~Safety barriers, grade separations, and/or barrier plantings should be provided to protect trail routes along heavily traveled roads.~~

~~Gates installed for trail users should be a minimum of three feet (3') in width and able to be self-closing. Vehicle gates, where necessary, should be a minimum of ten feet (10') in width, lockable and signed for no parking to prevent blockage for emergency access.~~

~~9.1.8 Signs. Six (6) types of signs should be used to manage uses along each trail. These signs include:~~

~~Identity signs will indicate through a common logo that the trail is part of Carson City's Eagle Valley Trail System, identify the specific trail name, and provide a space for recognition of trail ownership or joint agency management. Identity signs will be located at all staging areas, at trail intersections, and at intersections with roads (Reference Figure 8).~~

~~Trail route markers will indicate through a common logo, trail name sponsor, and mileages. Trail route markers will be located every one-quarter (1/4) mile along the trail or at significant directional changes in the trail. (Reference Figure 8).~~

~~Trail use signs will be located at all staging areas, at trail intersections, at intersections with roads and portray the following information (Reference Figure 8):~~

~~Which types of trail use are appropriate, permitted, or prohibited on the trail;~~

~~Distance to staging areas or intersections with other trails;~~

~~Other points of interest along the trail route; and~~

~~Accessibility conditions and other Americans with Disabilities Act (ADA) related information.~~

~~General use signs will be placed at each trail staging area and portray the following information:~~

~~Educating trail users about respecting private property along the trail route and/or any special land use considerations;~~

~~Restricting trail user parking on local streets; and~~

~~Restricting smoking and/or use of matches or lighters during high fire season.~~

~~Safety signs will be located on an as-needed basis along the trails and at staging areas and portray the following information:~~

~~Displaying warnings of upcoming underpasses, street intersections, blind curves, vertical clearances;~~

~~Providing information about water availability;~~

~~Advising trail users of the need to reduce speed or dismount and walk their bicycles or horses;~~

~~Warning of mountain lion or other wildlife danger;~~

Identifying any use restrictions during the fire season; and explaining the hierarchy of yielding among trail users.

Private property signs posted at regular intervals in conformance with legal requirements to remind the trail user not to trespass.

9.1.9— Benches. Benches for resting should be provided at regular intervals within one-half (½) mile of staging areas and along trail routes. Benches should be located at places with aesthetic qualities, viewpoints, and particularly at the end of any long uphill stretches.]

SECTION XXXX:

That Title 18 Appendix (CARSON CITY DEVELOPMENT STANDARDS), Division 9 (TRAIL STANDARDS), Section 9.2 (Community staging areas) is hereby amended (**bold, underlined** text is added, [~~stricken~~] text is deleted) as follows:

9.2 [Community staging areas.] Trailheads.

[Community staging areas] **Trailheads** are intended to serve the entire Carson City community.

[9.2.1] Location. It is preferable to locate [~~community staging areas~~] **trailheads** within designated parks and recreation areas or at other community **trailhead** facilities so that management responsibilities may be shared. [~~In any event, staging areas~~] **Trailheads** should be located only where there is adequate management capability. [~~Staging areas~~] **Trailheads** should be designed to adequately accommodate and manage anticipated use levels to prevent overflow parking onto local neighborhood streets. [~~Ideally, staging areas~~] **Trailheads** should be located on or near a public transit [~~route.~~] **route, which may be paved or unpaved. Wherever feasible, the design of a trail or trailhead should be consistent with the intended purpose of the Americans with Disability Act of 1990, 42 U.S.C. §§ 12101 et seq., to facilitate accessibility.**

[9.2.2— Facilities. Community staging areas should contain, at a minimum, adequate parking, potable water supply, sanitary facilities, and emergency telephones and access. The city should consider a range of other facilities appropriate to the trail uses that the community staging areas serve. These facilities might include: other general parking; identity, use, and safety signs; trail map dispensers; and public telephones. Where equestrian staging is provided, facilities could include: horse trailer parking; watering troughs; hitching rails; and loading platforms designed to accommodate ADA guidelines. Gates or removable bollards should be included at the street entrance to all community staging areas. Portable water for trail users and domestic animals permitted on the trail should be provided at staging areas, where practical. Trail routes where no potable water is available will be posted at staging areas with safety signs indicating such conditions.]

SECTION XXXX:

That Title 18 Appendix (CARSON CITY DEVELOPMENT STANDARDS), Division 9 (TRAIL STANDARDS), Section 9.3 (Neighborhood access points) is hereby repealed (**bold, underlined** text is added, [~~stricken~~] text is deleted) as follows:

~~[9.3 Neighborhood access points.~~

~~Neighborhood access points are not typically located on arterial or collector streets. They should provide limited parking and offer the opportunity for local residents to conveniently access trails.]~~

SECTION XXXX:

That Title 18 Appendix (CARSON CITY DEVELOPMENT STANDARDS), Division 9 (TRAIL STANDARDS), Section 9.4 (Americans with Disabilities Act (ADA)) is hereby repealed (**bold, underlined** text is added, [~~stricken~~] text is deleted) as follows:

~~[9.4 Americans with Disabilities Act (ADA).~~

~~Where feasible, the design of the trail system should recognize the intent of the ADA and should be made accessible to everyone. Based on topographic slope conditions, three (3) accessibility zones within the city are identified in the Eagle Valley trail system plan. These are: easy, moderate to difficult, and primitive. The Eagle Valley trail system plan defines the general characteristics of each zone. The final definition of each zone and ADA accessibility, as it pertains to a particular trail segment, should be made only after detailed site investigations has been conducted. Table B summarizes the preferred design criteria based on accessibility within these zones. All trail routes within the easy level of access should be designed to meet guidelines presented in Table C. Trails within moderate to difficult and primitive levels of access should be evaluated on a case-by-case basis.~~

Table B
Accessibility Zones

Criteria	Accessibility Zone* Easy Level of Access	Accessibility Zone* Moderate to Difficult Level of Access	Accessibility Zone* Primitive: Difficult Level of Access
Average slope conditions over entire area of trail	<10%	11%—20%	>20%

* Refer to Map 3 in the Eagle Valley trail system plan for accessibility zones for generalized interpretation

Table C
Summary of Accessible Design Guidelines for Trails[†]

Design Component	Accessibility Zone* Easy Level of Access	Accessibility Zone* Moderate to Difficult Level of Access	Accessibility Zone* Primitive: Difficult Level of Access
Maximum running slope	5%	8.33%	12.5%
Maximum interval of 5' by 5' passing areas**	200'	300'	400'
Optimum trail tread	6'-0"	5'-0"	4'-0"
Rest area interval	600'	900'	optional
Maximum ramp gradient	8.33%	10%	15%
Maximum ramp rise to landing	48"	60"	72"
Maximum ramp run to landing	40'	40'	40'
Maximum tread cross-slope	3%	3%	3%
Minimum vertical clearance	6'-8"	6'-8"	6'-8"

1— Based on guidelines developed in cooperation with federal agencies by PLEA Inc.

*— Refer to Map 3 in the Eagle Valley trail system plan for accessibility zone map for generalized interpretation

**— Not required if trail is a minimum of five feet (5') in width

Figure 1
Trail Structure Terminology

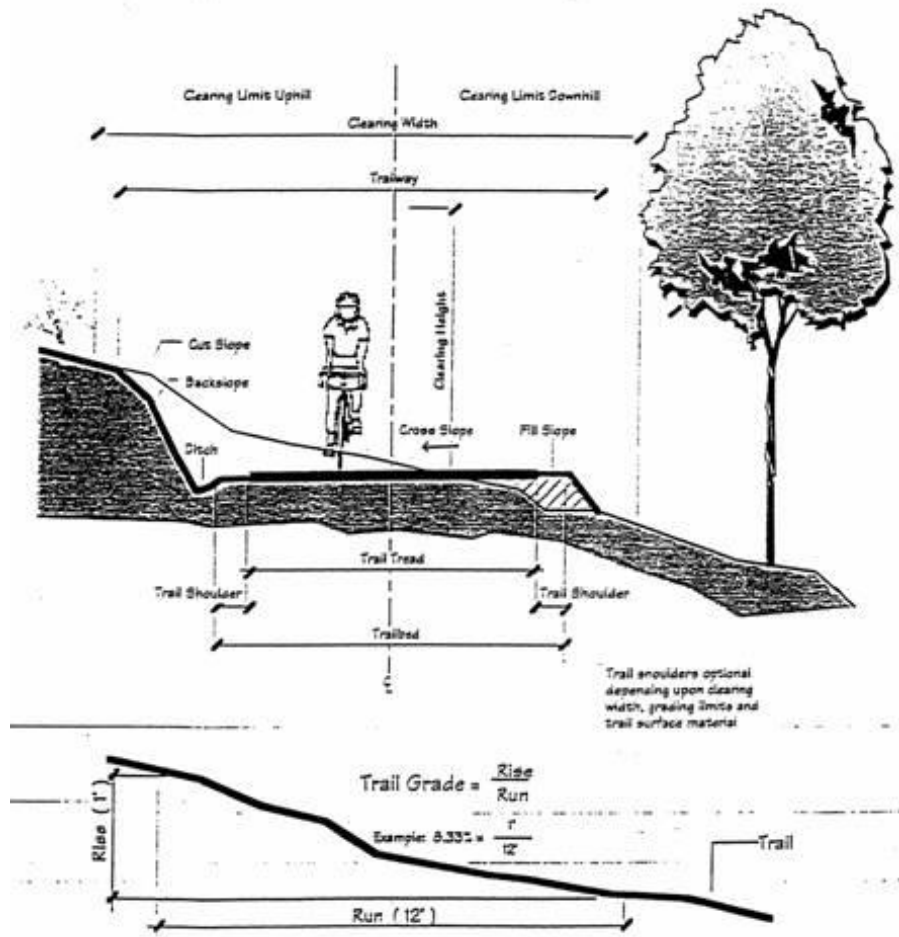
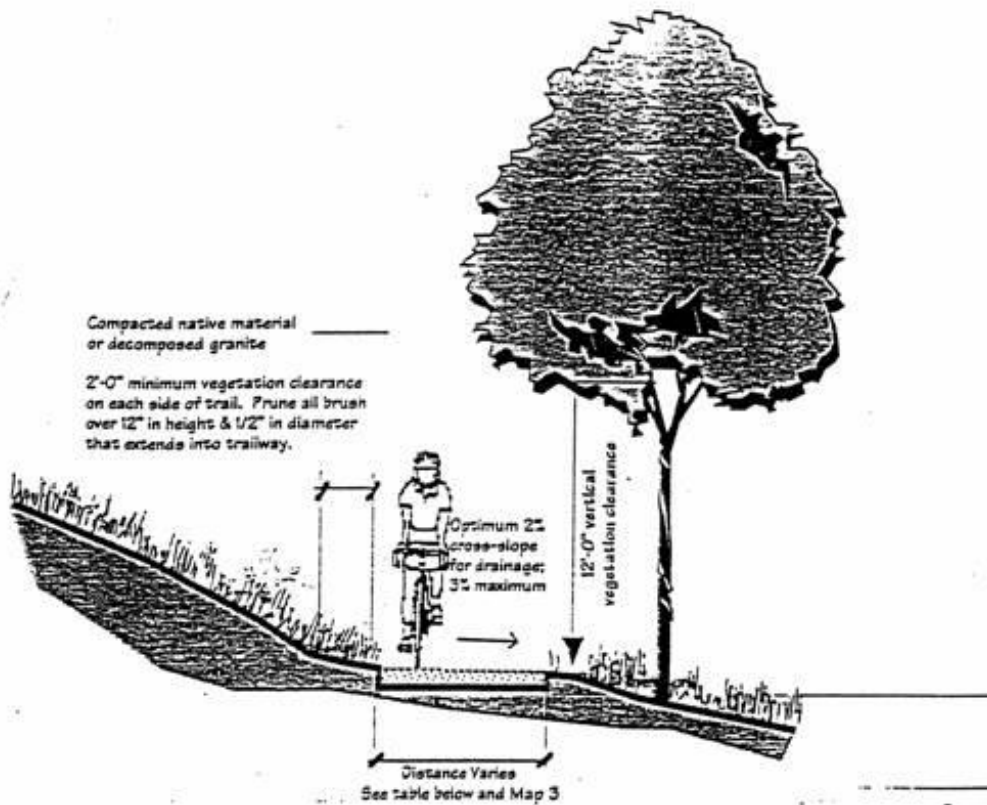
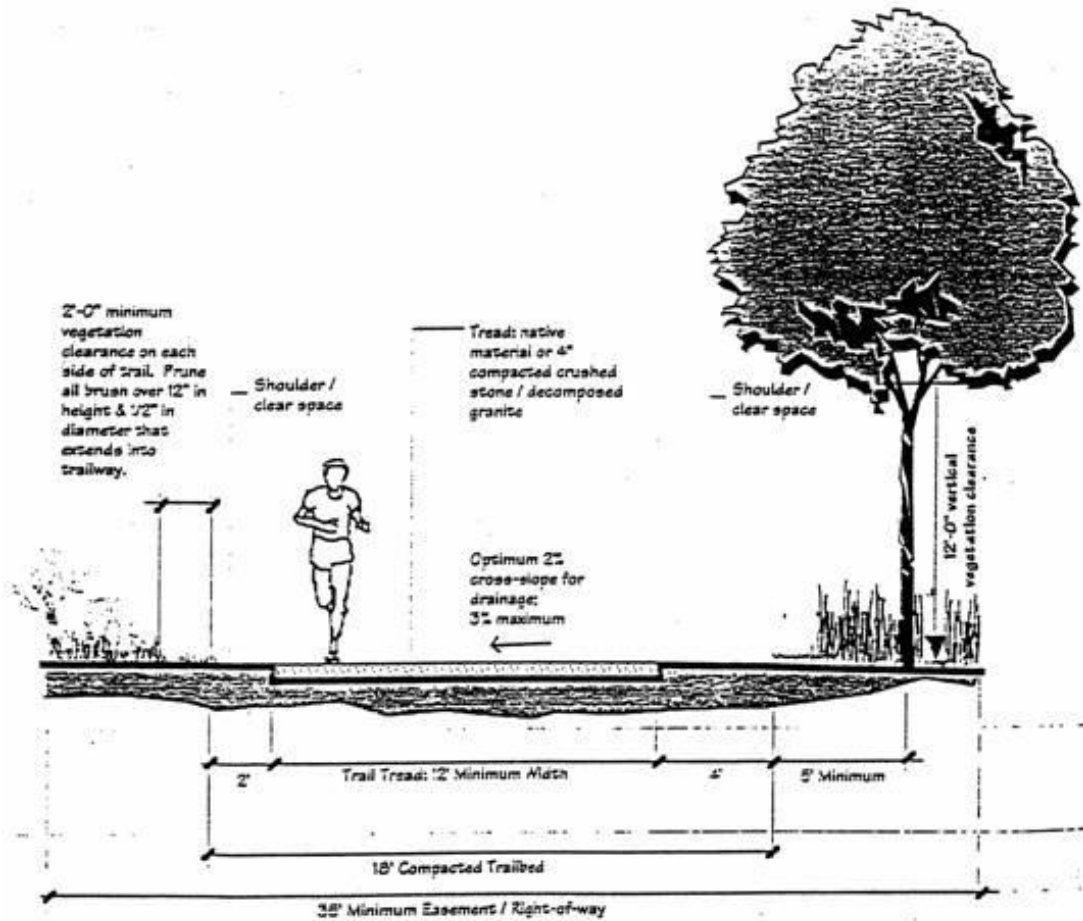

Figure 2
Single-Track Trail



	Easy	Moderate to Difficult	Primitive
Tread Width:	6'-0"	5'-0"	4'-0"
Sustained Running Slope (Maximum):	5%	6.3%	12.5%
Maximum Grade Allowed:	8.3%	10%	15%
-- for a maximum distance of:	30'	50'	not applicable

Figure 3
Initial Shared-Use/Conservancy Area Trail



Notes:

- 5% maximum grade
- Reference *Guide for the Development of Bicycle Facilities* prepared by the AASHTO Task Force on Geometric Design for details about horizontal alignment, sight distances, signing and marking, drainage, intersections, and grade-separation structures.

Figure 4
Paved Shared-Use Trail

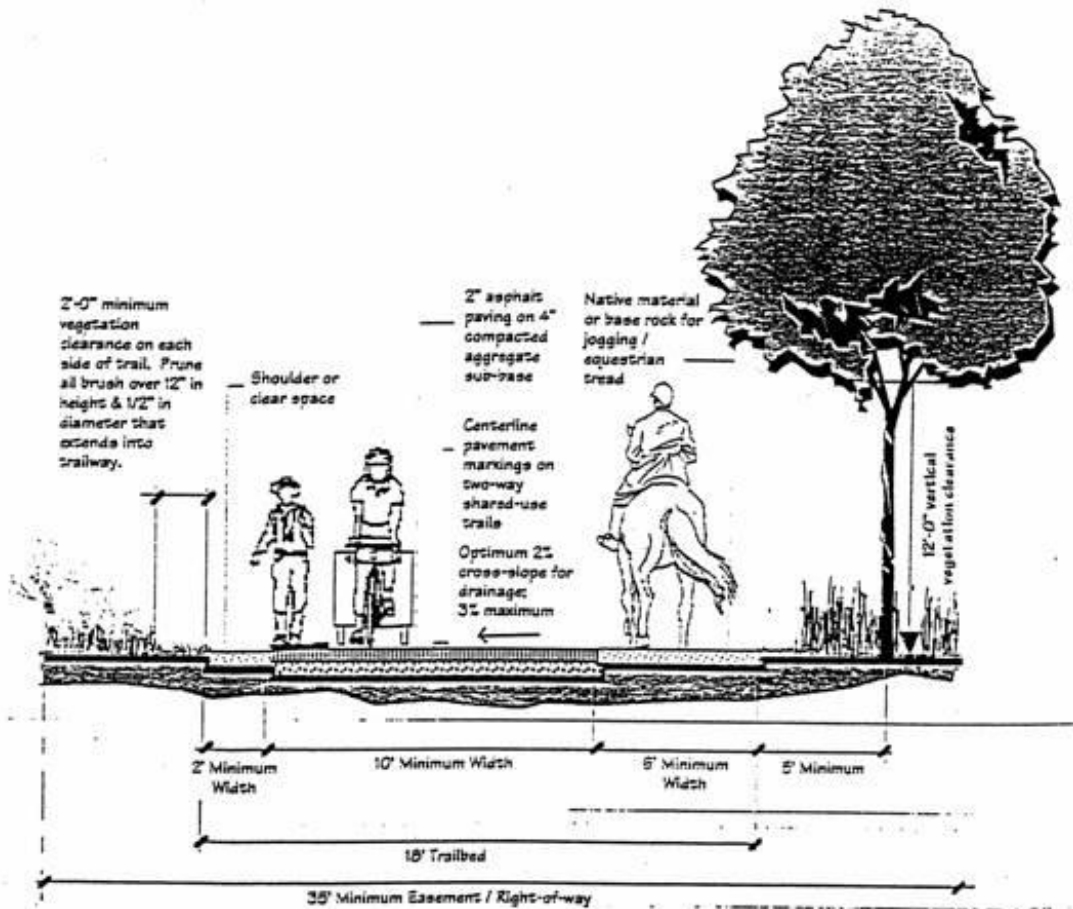

Notes:

- 5% maximum grade
- Reference *Guide for the Development of Bicycle Facilities* prepared by the AASHTO Task Force on Geometric Design for details about horizontal alignment, sight distances, signing and marking, drainage, intersections, pavement structure, and grade-separation structures.

Figure 5
Initial Bicycle Trail/Conservancy Area Trail

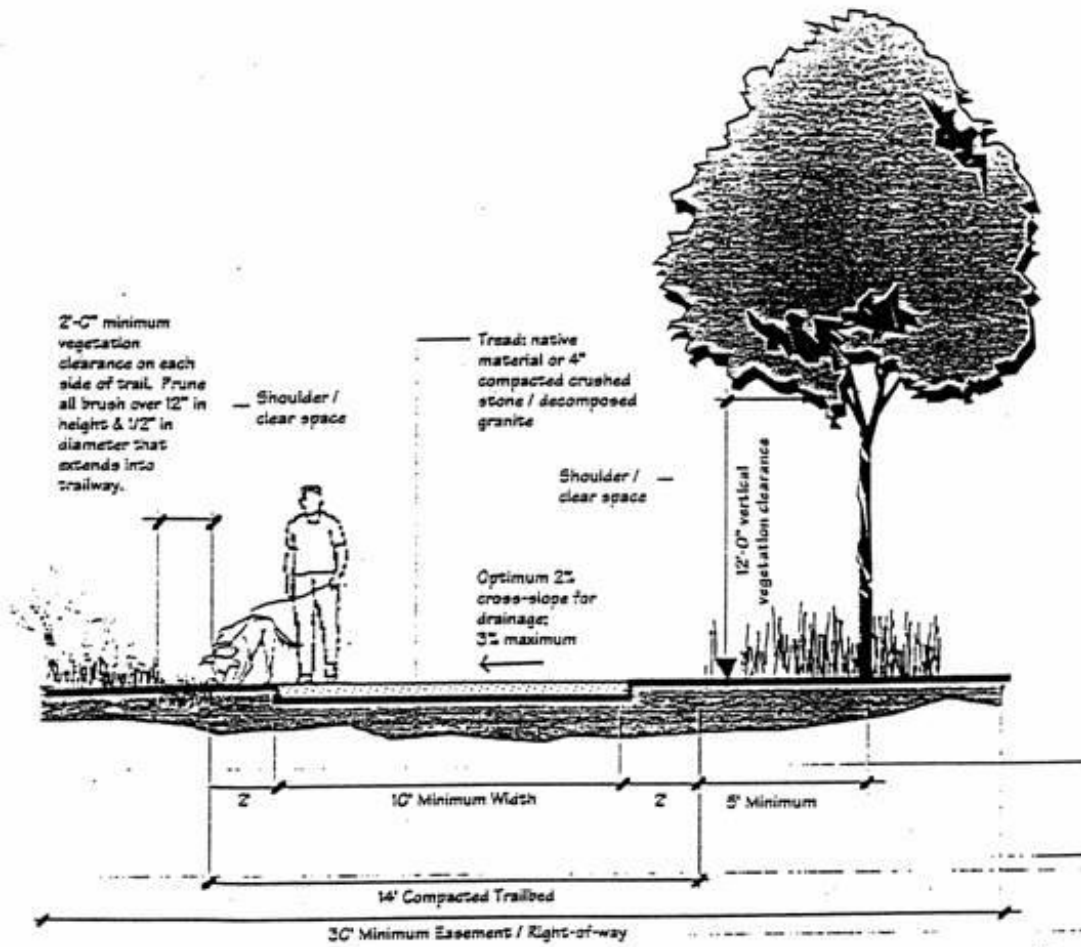

Notes:

- 5% maximum grade
- Reference *Guide for the Development of Bicycle Facilities* prepared by the AASHTO Task Force on Geometric Design for details about horizontal alignment, sight distances, signing and marking, drainage, intersections, and grade-separation structures.

Figure 6
Paved Bicycle Trail

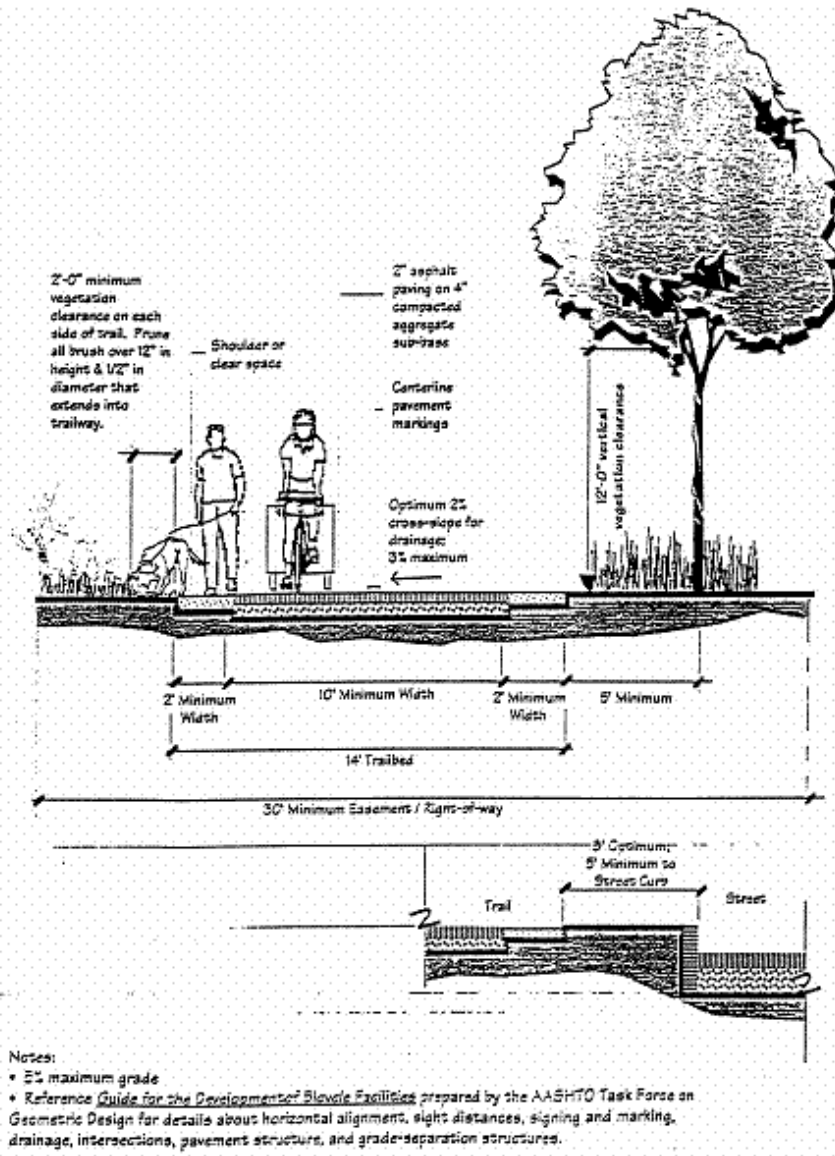

Figure 7
Plan of Typical At-Grade Crossing

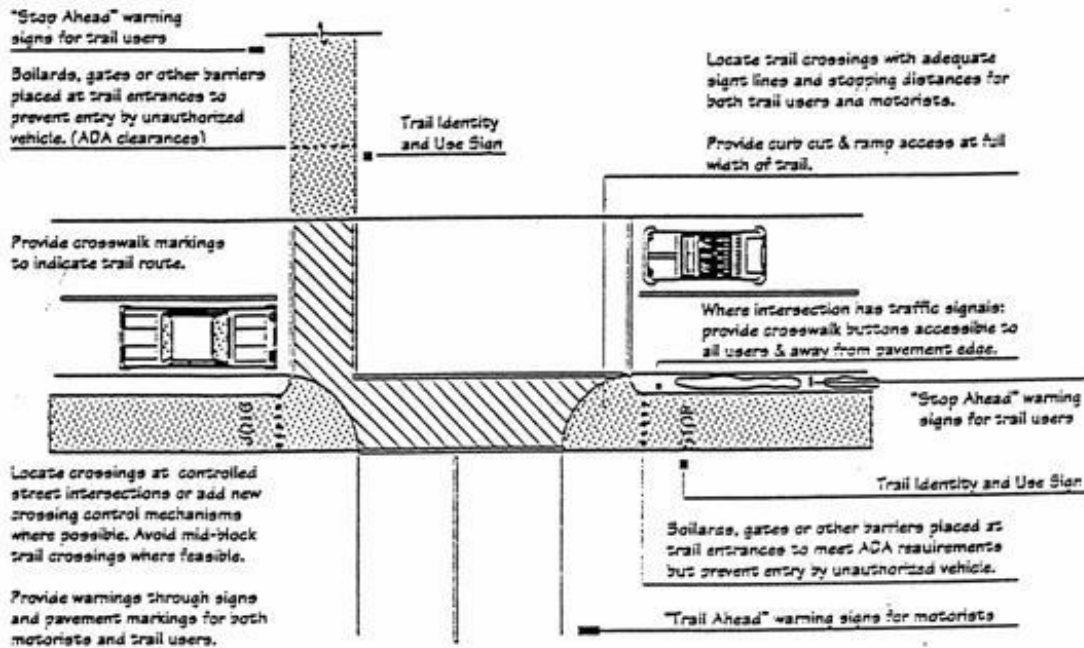
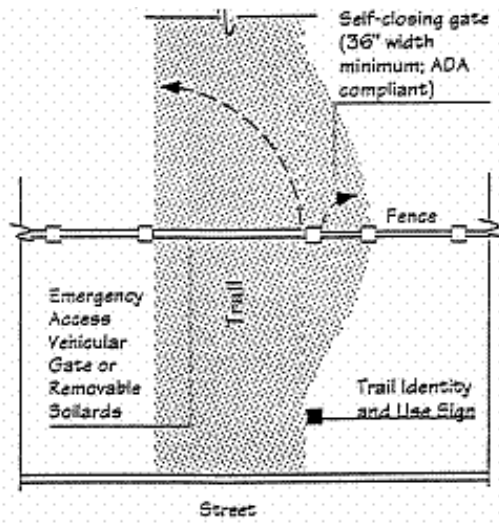
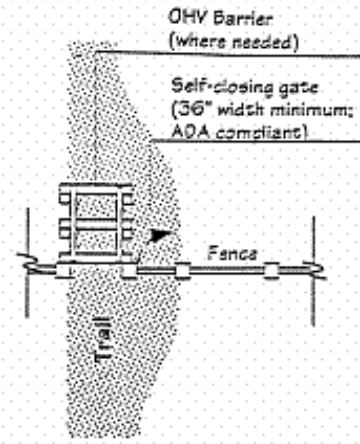

Figure 8
Trail Gates



A: Plan -- Trail Gates



B: Plan -- OHV Barrier

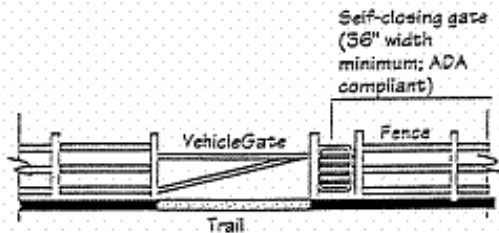

A: Elevation -- Trail Gates

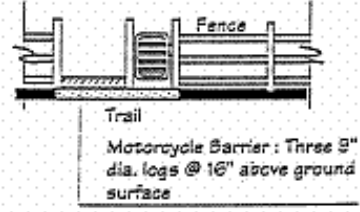

B: Elevation -- OHV Barrier

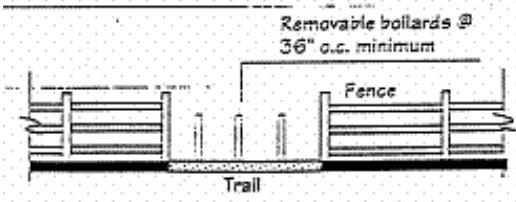

A: Elevation -- Bollards

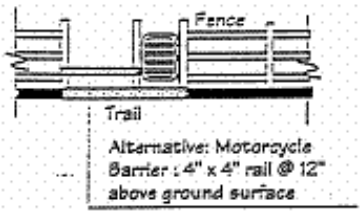

B: Elevation -- Alternative OHV Barrier

**Figure 9
Trail Identity and Use Signs**

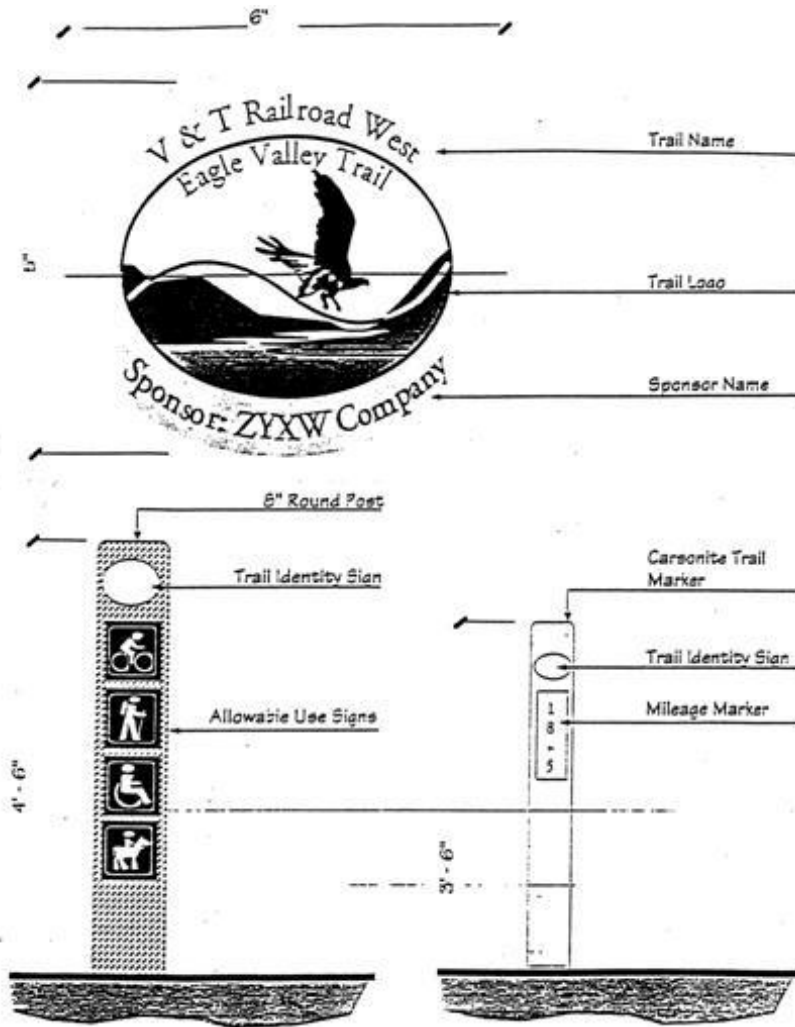

]

SECTION XXXX:

That Title 18 Appendix (CARSON CITY DEVELOPMENT STANDARDS), Division 10 (MOBILEHOME PARKS), Section 10.1 (Mobilehome parks) is hereby amended (**bold, underlined** text is added, [~~stricken~~] text is deleted) as follows:

10.1 [~~Mobilehome~~] Mobile home parks.

10.1.1 General. [~~Mobilehome~~] **Mobile home** parks hereinafter constructed or remodeled in Carson City shall be done in accordance with Carson City Municipal Code Title 18 and in accordance with these design guidelines.

10.1.2 Site Plans. Each application to construct a [~~mobilehome~~] **mobile home** park shall be submitted to the building division and be accompanied by:

- a. Site Plans. 5 site plans of the [~~mobilehome~~] **mobile home** park including the minimum following descriptive data:
1. Proposed name of park, and a legal description of the land;
 2. Name and address of the owner and applicant;
 3. Name, address and phone number of land planner, engineer or surveyor preparing plans;
 4. Scale, north arrow and date of the map;
 5. A small scale location map showing relationship of [~~mobilehome~~] **mobile home** park to existing neighborhood and the existing zoning of the site and adjacent properties;
 6. The location, widths and names of all public streets within or adjacent to park;
 7. Topography by contours of the site, adequate to show the character and drainage of the land;
 8. Dimensions of all boundaries of parks, net and gross acreage of the park;
 9. Dimensions of all [~~mobilehome~~] **mobile home** spaces and the total number of spaces;
 10. Dimensions and net acreage of open space recreational area;
 11. Landscaping plans containing the information required by Carson City Municipal Code;
 12. Sewage disposal method and details of collections;
 13. Water supply method and details of distribution, details of water meter location, details of fire hydrant placement;
 14. Locations, dimensions and designations of all accessory buildings and structures;
 15. Sketch showing location and size of any proposed identification signs including all advertising copy proposed on the face of such sign;
 16. Existing conditions of site, including buildings, structures and wells, drainage ditches existing and proposed storm drainage details, and such additional information that may be required;
 17. Shall-serve letters for water supply and sewage disposal;
 18. Existing and proposed gas and electrical distribution lines;
 19. Trash disposal locations;
 20. The number of [~~mobilehome~~] **mobile home** spaces available to tenants with children;
 21. A generalized plot plan not larger than 8 inches by 11 inches, illustrating the overall park development;
 22. Location and description and perimeter fencing.

10.1.3 [~~Mobilehome~~] **Mobile home** Park Requirements.

- a. Front Setback. A minimum of 4 feet shall be provided from the unit or structural wall or overhang, whichever protrudes the most, to the front boundary line of the space.
If off-street parking is provided, 20 feet is required [~~to be provided, measured from~~] **between** the unit or structural wall or overhang, whichever protrudes the most, to the front space boundary line . [~~of the space, shall off-street parking be provided entirely within this area.~~]
- b. Street Side Setback. When a [~~mobilehome~~] **mobile home** is located at a corner space, the minimum street side setback shall be 4 feet measured from the unit or structural wall or overhang, whichever protrudes the most, to the street side space boundary line.
- c. Rear Setback. [~~Mobilehome~~] **Mobile home** units shall observe a 10 foot rear setback, measured from unit or structural wall or overhang to the adjacent unit structural wall or overhang, whichever protrudes the most.
- d. Side Setback. [~~Mobilehome~~] **Mobile home** units placed side to side shall observe a 10 foot setback measured from unit or structural wall to unit or structural wall or overhangs, whichever protrudes the most, to the adjacent unit.
- e. Common Walls. The utilization of common walls for structures occupying adjacent lots is permitted subject to the provisions of the latest adopted editions of the Building Code currently adopted by Carson City.
- f. Detached accessory structures shall observe a 6 foot setback from any other structure within the same [~~mobilehome~~] **mobile home** space, and 10 foot setback from any structure on an adjacent [~~mobilehome~~] **mobile home** space. Attached or adjacent accessory structures shall observe a 10 foot setback from any structure on an adjacent [~~mobilehome~~] **mobile home** space. All accessory structures proposed to be attached and supported from a [~~mobilehome~~] **mobile home** must be approved by State Division of Manufactured Housing. All accessory structures must meet requirements of the latest edition of the Building Code as currently adopted by Carson City. Permits are required for all buildings and structures except where specifically exempted.
- g. No [~~mobilehome~~] **mobile home** shall be harbored closer than 10 feet to any exterior property line of a park.
- h. The entire [~~mobilehome~~] **mobile home** park perimeter shall be improved by the utilization of a combination of fences, berms and landscaping features. These features shall enclose the park on all sides except at access points.
- i. Access to [~~mobilehome~~] **mobile home** parks shall be designed to minimize congestion and traffic hazards and provide for safe movement of traffic at the entrance or exists to adjoining streets.
- j. Streets shall have a minimum paved section not less than 24 feet in width, and no on-street parking shall be allowed on a street having a width of 24 feet.
- k. Where on-street parking is desired on a single side of the street, a paved section not less than 32 feet in width is required. Where on-street parking is desired on both sides of the street a paved section not less than 40 feet in width is required.

- l. All streets shall be properly signed and lighted with the equivalent of a 50 watt lamp for each 100 lineal feet of street, or guard light each 300 feet.
- m. Each [~~mobilehome~~] **mobile home** space shall have designated a minimum of 2 off-street parking areas within the lot.
- n. Provisions shall be made for guest parking space for each 6 [~~mobilehome~~] **mobile home** spaces.
- o. All vehicle parking spaces and driveways shall be improved and shall meet Carson City requirements.
- p. All [~~mobilehome~~] **mobile home** parks shall have at least 1 recreation open space area accessible from all spaces; the cumulative size of which recreation area shall not be less than 5% of the gross [~~mobilehome~~] **mobile home** park area. **The recreation open space area must be privately owned and maintained.**

Said recreation area shall be improved to meet the requirements of development standards Division 3 (Landscaping), except that as a minimum, the amount of area required to be in landscaping shall equal or exceed 15% of the gross park area, and the use of automated water irrigation system is mandatory. The use of landscaping treatment shall be concentrated along public [~~right-of-ways~~] **rights-of-way** bordering the park entrances, interior space frontages, and the recreational area. Landscaping must be designed to preserve adequate sign distance areas for motorist and pedestrians.

- q. Bike paths, jogging paths, or walking trails may be incorporated into the overall development plan.
- r. The provisions of Section 9.06.120 of the Carson City Municipal Code shall govern the release of discharge into the atmosphere of particulate matter such as sand, dust, or dust particles and the method of mitigation for exposed ground surfaces.
- s. Storage, collection, and disposal of garbage and refuse shall be in conformance to any applicable statutes, ordinances and guidelines of the state of Nevada and city health department.
- t. Installation of liquified petroleum gas or fuel oil containers within a [~~mobilehome~~] **mobile home** park shall be in conformance to any applicable statutes, ordinances and guidelines of the state of Nevada, Carson City health and fire departments, and building division.
- u. In every [~~mobilehome~~] **mobile home** park there shall be installed and maintained fire hydrants and fire extinguishers of the number and size, and in such locations as may be required by the fire department. Each [~~mobilehome~~] **mobile home** lot shall be numbered and the number displayed on a location visible from the street fronting the unit.
- v. There shall be provisions for the separation of pedestrians and vehicular traffic by the provision of sidewalks, walkways or improved pathways throughout the park [~~and~~] **which** may be limited to 1 side of the street.
- w. The maximum height of any [~~mobilehome~~] **mobile home** or structure, within a [~~mobilehome~~] **mobile home** park, is 26 feet.

SECTION XXXX:

That Title 18 Appendix (CARSON CITY DEVELOPMENT STANDARDS), Division 11 (HEALTH), Section 11.1 (Environmental Health Department requirements) is hereby amended (**bold, underlined** text is added, [~~stricken~~] text is deleted) as follows:

11.1 [~~Environmental Health Department requirements.~~] Jurisdiction.

The Environmental Health [~~Department (EHD).~~] **Section of the Nevada Division of Public and Behavioral Health of the Department of Health and Human Services** regulates [a number of] **certain** areas related to development which includes:

Individual Sewage Disposal System (ISDS), commonly known as a septic system.

Medical Waste Program.

The Environmental Control Authority of the Department of Public Works regulates certain areas related to development which includes:

[~~Septic System Design;~~]

Pretreatment [~~Program;~~] **Program.**

Industrial Waste Disposal [~~Program;~~] **Program.**

Solid Waste Management [~~Program;~~]

[~~Medical Waste Program.~~] **Program.**

SECTION XXXX:

That Title 18 Appendix (CARSON CITY DEVELOPMENT STANDARDS), Division 11 (HEALTH), Section 11.2 (Septic system design) is hereby amended (**bold, underlined** text is added, [~~stricken~~] text is deleted) as follows:

11.2 Septic system design.

11.2.1 See **chapter 444 of the** Nevada Administrative Code, [(NAC), sections 444.750 through 444.8396, inclusive.]

11.2.2 [~~The applicant shall~~] **An applicant for a permit to install a septic system must** submit plans to the [~~building department~~] **Building Division of the Department** for distribution to the [~~EHD. Prior to~~] **Environmental Health Section of the Nevada Division of Public and Behavioral Health of the Department of Health and Human Services. Before** the issuance of a septic permit, the applicant [~~shall meet~~] **must satisfy** all applicable state and [~~city regulations. Applicant shall contact~~] **City requirements. The applicant is responsible for contacting** the [~~environmental health department.~~] **Environmental Health Section as may be necessary pursuant to state law.**

SECTION XXXX:

That Title 18 Appendix (CARSON CITY DEVELOPMENT STANDARDS), Division 11 (HEALTH), Section 11.3 (Industrial waste disposal program) is hereby amended (**bold, underlined** text is added, [~~stricken~~] text is deleted) as follows:

11.3 Industrial waste disposal program.

The major focus of this program is to protect groundwater resources, landfill personnel, and the public by ensuring that no hazardous wastes are disposed at the landfill. Many industries generate a non-reusable by-product that must be discarded. This type of waste is often suitable for landfill disposal, however, a change in raw materials or processing techniques can render a hazardous waste. Due to this fact, the [~~EHD~~] **Environmental Control Authority of the Department of Public Works** inspects [~~and samples~~] all potential sources of hazardous waste to determine if the waste is acceptable for disposal. If the waste is not hazardous, a manifest is issued to the industry allowing transport to the landfill. The manifest system provides a tracking mechanism allowing a full accounting of industrial wastes accepted at the landfill. [~~If a hazardous waste is found, the EHD coordinates with the Nevada Department of Environmental Protection (NDEP) to ensure that it is properly transported and disposed at a certified hazardous waste disposal site.~~] **A person who wishes to dispose of industrial waste at the landfill is required to provide test of any samples that are required by state or federal laws and regulations, the provisions of this Code or any policy or procedure of the City. If a waste is determined to be hazardous, the Environmental Control Authority must provide to the person a list of entities located in Northern Nevada that are certified in the disposal of hazardous waste. Except as otherwise specifically required by state or federal law or regulations, it is all times the responsibility of the person to ensure the proper disposal of hazardous waste.**

SECTION XXXX:

That Title 18 Appendix (CARSON CITY DEVELOPMENT STANDARDS), Division 11 (HEALTH), Section 11.4 (Solid waste management program) is hereby amended (**bold, underlined** text is added, [~~stricken~~] text is deleted) as follows:

11.4 Solid waste management program.

Carson City owns the landfill located east of the city. The Carson City sanitary landfill accepts municipal solid waste and [~~construction/demolition~~] **construction or demolition** waste. Hazardous wastes are strictly prohibited. The [~~EHD~~] **Environmental Control Authority of the Department of Public Works** tracks all asbestos-related building demolitions and renovations from the time of building permit application to the ultimate disposal of the asbestos. This is done

to ensure that all asbestos abatement is performed in accordance with the federal regulations regarding removal, transportation, and disposal. This protects the [~~asbestos workers~~] **City** and the public from the health risks of asbestos exposure. All asbestos is segregated from other municipal solid waste and immediately buried in an area which is surveyed in order to maintain a permanent record of its location.

SECTION XXXX:

That Title 18 Appendix (CARSON CITY DEVELOPMENT STANDARDS), Division 11 (HEALTH), Section 11.5 (Medical waste program) is hereby amended (**bold, underlined** text is added, [~~stricken~~] text is deleted) as follows:

11.5 Medical waste program.

Since 1993, the [~~EHD~~] **Environmental Health Authority of the Department of Public Works** has enforced a "medical waste program." Enforcement authority for this program is provided for in **title 12 of CCMC [12.12.]**. All facilities in Carson City that generate a potentially infectious waste are required to properly containerize this waste in accordance with federal, state, and local regulations. This waste must not be co-mingled with normal refuse. The infectious waste is manifested, then transported separately to the landfill for immediate burial.

SECTION XXXX:

That Title 18 Appendix (CARSON CITY DEVELOPMENT STANDARDS), Division 12 (TRANSPORTATION), Section 12.1 (General) is hereby amended (**bold, underlined** text is added, [~~stricken~~] text is deleted) as follows:

12.1 General.

All streets [~~will~~] **in Carson City must conform and** be improved [~~and conform~~] **pursuant** to the requirements of this [~~division.~~] **Division.**

SECTION XXXX:

That Title 18 Appendix (CARSON CITY DEVELOPMENT STANDARDS), Division 12 (TRANSPORTATION), Section 12.2 (Standards) is hereby amended (**bold, underlined** text is added, [~~stricken~~] text is deleted) as follows:

12.2 Standards.

Design and construction of streets and related improvements [~~will~~] **must** conform to the most recent edition of the [~~following:~~] **following publications:**

1. "Guidelines for Urban Major Street Design," by the Institute of Transportation ~~[Engineers.]~~ **Engineers (ITE).**
2. "A Policy on Geometric Designs of Highways and Streets," **commonly referenced as the Green Book,** by the American Association of State Highway and Transportation Officials (AASHTO).
3. "Manual on Uniform Traffic Control Devices," **commonly referenced as the MUTCD,** by the Federal Highway ~~[Administration.]~~ **Administration (FHWA).**
4. "Guide for Development of ~~[New]~~ Bicycle Facilities," by the American Association of State Highway and Transportation ~~[Officials.]~~ **Officials. (AASHTO)**
5. "Standard Details & Specifications for Public Works Construction," **commonly referenced as the Orange Book,** by Regional Transportation, Commission of Washoe County, Washoe County, City of Sparks, City of Reno, Carson City, City of Yerington as modified and adopted by Carson City.
- 6. "Roadside Design Guide," by the American Association of State Highway and Transportation Officials (AASHTO).**

SECTION XXXX:

That Title 18 Appendix (CARSON CITY DEVELOPMENT STANDARDS), Division 12 (TRANSPORTATION), Section 12.3 (Street widths and alignment) is hereby amended (**bold, underlined** text is added, ~~[stricken]~~ text is deleted) as follows:

12.3 Street widths and alignment.

Street alignments will conform to the Carson City master plan. Additional right-of-way will be provided near intersections as required by the city in order to facilitate turning movements.

Streets with centerline offsets at intersections of less than ~~[one hundred twenty five feet (125') are not allowed.]~~ **150 feet for local and collector roads and 250 feet for arterial roads are prohibited.** All improvements ~~[will]~~ **must** be centered within the dedicated right-of-way or dedicated street easement.

Adjustments to the street widths, curb return radii, and other traffic calming techniques will be considered when pedestrian and bicycle safety and convenience are important. Traffic calming techniques will be considered on a case-by-case basis by the city.

SECTION XXXX:

That Title 18 Appendix (CARSON CITY DEVELOPMENT STANDARDS), Division 12 (TRANSPORTATION), Section 12.4 (Access) is hereby amended (**bold, underlined** text is added, ~~[stricken]~~ text is deleted) as follows:

12.4 Access.

[At least two (2)] **Not less than two** means of ingress and egress to [city] **City** standards [will] **must** be provided to serve a subdivision [~~or development, with the exception of a single cul-de-sac subdivision. A single cul-de-sac subdivision may be approved with only one (1) means of access and egress.~~]. **Except as otherwise waived by the City Engineer, if a public street dead ends into a proposed subdivision, the public street must connect to the street located inside the subdivision.** An emergency access easement or fire access easement [is] **shall** not **be deemed** a secondary means of access and cannot be used to [~~waive or modify~~] **satisfy** the requirements of this section [~~unless~~] **except as otherwise** approved by the [~~city engineer.~~] **City Engineer.**

SECTION XXXX:

That Title 18 Appendix (CARSON CITY DEVELOPMENT STANDARDS), Division 12 (TRANSPORTATION), Section 12.5 (Off-site improvements) is hereby amended (**bold, underlined** text is added, [~~stricken~~] text is deleted) as follows:

12.5 Off-site improvements.

Streets or access adjacent to or necessary to serve a development which are not within the boundaries of the [~~development,~~] **development** but are dedicated public [~~right of ways, will~~] **rights-of-way must** be improved with development to standards promoting public access, safety and welfare.

SECTION XXXX:

That Title 18 Appendix (CARSON CITY DEVELOPMENT STANDARDS), Division 12 (TRANSPORTATION), Section 12.6 (Right-of-way and easements) is hereby amended (**bold, underlined** text is added, [~~stricken~~] text is deleted) as follows:

12.6 Right-of-way and easements.

All necessary right-of-way or easement acquisition outside the boundaries of a subdivision or development, including agreements as to access, ownership and maintenance, [will] **must** be completed at the time [~~of submittal of~~] **an** application for a development [~~permit.~~] **permit is submitted.** Right-of-way widths [will] **may** not be less than **the widths** shown in Table [~~12.1.~~] **12.1 or be a minimum of 1 foot from the back of a sidewalk and 7 feet from the edge of pavement, whichever is greater.**

In areas of possible fire hazards, at the [~~urban interface,~~] **Wildland Urban Interface,** unobstructed fire protection equipment access easements not less than [~~twenty feet (20')~~] **20 feet**

wide ~~[will]~~ **must** be dedicated from the public street to the subdivision or development boundary as determined by the ~~[fire chief.]~~ **Fire Chief**. Permanent emergency access ~~[will]~~ **must** be designed and constructed to comply with the requirements of Section 12.12.13 ~~[Emergency Access Streets.]~~ **of this Division.**

**Table 12.1
Minimum Right-of-Way Widths**

Functional Classification	Minimum Right-of-Way Width (feet)
Arterial	80
Collector	60
Industrial Street	60
Local Street	50

~~[Note: All existing principal arterial roadways in Carson City are maintained under the jurisdiction of the Nevada Department of Transportation. Right of way]~~ **Rights-of-way** for principal arterials **owned by the Nevada Department of Transportation** will be coordinated with the Nevada Department of Transportation and comply with their requirements.

SECTION XXXX:

That Title 18 Appendix (CARSON CITY DEVELOPMENT STANDARDS), Division 12 (TRANSPORTATION), Section 12.7 (Streets along property boundaries) is hereby amended (**bold, underlined** text is added, ~~[stricken]~~ text is deleted) as follows:

12.7 Streets along property boundaries.

Streets must not be located along property boundaries unless required by a city adopted street plan. A proposed access street lying along a boundary, which is within the development or off-site but within an easement already dedicated to the city, must be dedicated and constructed to city standards. A proposed street lying along the boundary of a development or subdivision, which is within the development or is off-site within an easement dedicated to the city, that is impacted by that subdivision or development, must be dedicated and constructed by that subdivision or development. If the proposed street, which is in the development or subdivision, does not offset any of the traffic of the development but is shown on the master plan or city adopted street pattern, the street must be dedicated.

SECTION XXXX:

That Title 18 Appendix (CARSON CITY DEVELOPMENT STANDARDS), Division 12 (TRANSPORTATION), Section 12.8 (Half streets) is hereby amended (**bold, underlined** text is added, ~~[stricken]~~ text is deleted) as follows:

12.8 Half streets.

Half streets are permitted. The minimum street section permitted [will] **must** be [twenty-six feet (26') in width.] **26 feet wide plus any additional width that may be necessary to accommodate parking if parking spaces are required.**

SECTION XXXX:

That Title 18 Appendix (CARSON CITY DEVELOPMENT STANDARDS), Division 12 (TRANSPORTATION), Section 12.9 (Temporary cul-de-sac and dead end streets) is hereby amended (**bold, underlined** text is added, [~~stricken~~] text is deleted) as follows:

12.9 Temporary cul-de-sac and [~~dead-end~~] **dead-end** streets.

Streets will be extended to the subdivision/development boundary for future development. Where subdivisions are phased, streets will be extended to the subdivision phase boundary line. Streets extending to the subdivision or development boundary which are proposed for future extension and exceed two hundred feet (200') in length are to be provided with temporary cul-de-sacs. The future removal of the cul-de-sac and its replacement to city standard street improvements will be provided with the extension of the street by future development. Right-of-ways or easements will be provided by the developer for the temporary cul-de-sac. For streets less than two hundred feet (200') in length a barricade will be placed at the end of the street.

SECTION XXXX:

That Title 18 Appendix (CARSON CITY DEVELOPMENT STANDARDS), Division 12 (TRANSPORTATION), Section 12.10 (Pavement sections) is hereby amended (**bold, underlined** text is added, [~~stricken~~] text is deleted) as follows:

12.10 Pavement sections.

Pavement sections [will] **must** be based on subgrade strength values determined by resistance (R) value or California bearing ratio (CBR) as shown in the soils engineering report. [~~Refer to division 17, soils engineering reports, for requirements for the soils report. As a minimum, pavement sections will conform to the requirements of this division.~~]

Notwithstanding any other provision of this section, pavement sections may not be constructed below the minimum requirements by functional classification as shown in the standard details used by the City.

SECTION XXXX:

That Title 18 Appendix (CARSON CITY DEVELOPMENT STANDARDS), Division 12 (TRANSPORTATION), Section 12.11 (Design standards) is hereby amended (**bold, underlined** text is added, [~~stricken~~] text is deleted) as follows:

12.11 Design requirements.

Streets will be designed and constructed in accordance with the requirements of this division and the requirements of the Carson City code.

12.11.1 Street Grades. All streets will have a minimum longitudinal grade of four-tenths percent (0.4%). Arterial streets may have a maximum allowable grade of six percent (6%). Collectors and industrial streets will have a maximum grade of six percent (6%). Local streets may have a maximum allowable grade of ten percent (10%). The following criteria will also apply to street grades:

1. Grades in excess of eight percent (8%) will be limited to a horizontal tangent length of four hundred feet (400'). Grades in excess of ten percent (10%) will be limited to critical design issues and will receive specific approval from the [~~city engineer.~~] **City Engineer.**
2. Street intersections will not be allowed when the grade on the primary street exceeds six percent (6%).
3. "Roller-coaster" and "hidden-dip" patterns are not allowed.
4. Sharp horizontal curvature will not be introduced at or near the top of a pronounced crest vertical curve or near the bottom of a pronounced sag vertical curve.

12.11.2 Street Intersections. Street grades on the minor legs of intersections will not exceed four percent (4%) for a minimum distance of fifty feet (50') measured from the extension of the face of curb or edge of pavement of the primary street from the intersection (improved to full city standards). Additional criteria are as follows:

1. Street intersections of two (2) local streets with a stop condition at all corners do not require a vertical curve at the intersection of the crown section with the street grade.
2. Other street intersections will require a vertical transition at the intersection of the crown section with the street grade.
3. Whenever a street or highway is proposed requiring a separation of grades or special form of intersection design, the improvements will be designed to provide for the intersection design, and all lots or building sites will be practical and conform to the requirements for grading plans.
4. Intersection sight distance (a clear vision triangle) will be maintained at each corner created by the intersection of two (2) streets, or the intersection of a driveway with a street. When designing a new project, the engineer will ensure that no embankments, hills, buildings, fences, walls, signs, foliage, or other visual

obstructions encroach higher than three feet (3'), or lower than eight feet (8') into the clear vision triangle as measured from the top of curb, or as measured from the edge of pavement where no curb exists. If there are sight distance restrictions, the engineer will mitigate these restrictions by reconfiguring the roadway geometrics, moving the proposed intersection location, or eliminating the obstruction. The owner will also provide for protection of the clear vision triangle from future obstacles by creating corner easements or dedicating additional corner right-of-way. The clear vision triangle area is defined [~~in Table 12.2.~~] **by the edition of the AASHTO Green Book most recently adopted by the City.**

5. Objects narrower than four inches (4") in diameter, such as sign posts, are exempt from the clear vision area requirements. Where there are existing topographical features, buildings, or other fixed objects that cannot be removed to meet the minimum intersection sight distance requirements [~~shown in Table 12.2, the city~~], **as set forth in the edition of the AASHTO Green Book most recently adopted by the City, the City** may allow the minimum stopping sight distance requirements [~~shown in Table 12.3~~] to control as an absolute minimum provided there are no other intersection locations where greater sight distance can be obtained.

[Table 12.2
Minimum Intersection Sight Distance

Posted Speed or Design Speed (mph)	⁽¹⁾ Minimum Intersection Sight Distance (ft) ⁽²⁾ Yield or Uncontrolled	⁽¹⁾ Minimum Intersection Sight Distance (ft) ⁽³⁾⁽⁴⁾ Stop Sign Controlled 2-3 Lane	⁽¹⁾ Minimum Intersection Sight Distance (ft) ⁽³⁾⁽⁴⁾ Stop Sign Controlled 4-5 Lane	⁽¹⁾ Minimum Intersection Sight Distance (ft) ⁽³⁾⁽⁵⁾ Signal Controlled
20	90	200	225	225
25	110	250	275	300
30	130	300	350	375
35	155	350	400	475
40	180	400	450	575
45	N/A	450	500	700
50	N/A	500	550	850
55	N/A	550	625	1,000
60	N/A	600	675	1,150

Notes:

(1) Taken in part from AASHTO, A Policy on Geometric Design of Highways and Streets, 1990.

(2) Measured along the center of the approaching travel lanes of both streets, and measured from an eye height of three and one half (3.5) feet to an approaching object height of four and one-quarter (4.25) feet.

(3) Measured along the center of the approaching travel lanes, as observed from a point fifteen (15) feet back from the edge of traveled way, and measured from an eye height of three and one-half (3.5) feet to an approaching object height of four and one-quarter (4.25) feet.

(4) Sight distance for a vehicle turning left into a two-lane or four-lane roadway across a vehicle approaching from the left or right.

(5) Sight distance for a vehicle turning right into a two-lane or four-lane roadway and attaining eighty-five percent (85%) of design speed without being overtaken by a vehicle approaching from the left and which has been reduced to eighty-five percent (85%) of design speed.

**Table 12.3
Minimum Stopping Sight Distance**

Posted Speed or Design Speed (mph)	(1)(2)	(1)(2)	(1)(2)	(1)(2)	(1)(2)	(1)(2)	(1)(2)
	Minimum Stopping Sight Distance (ft) Downgrade -9%	Minimum Stopping Sight Distance (ft) Downgrade -6%	Minimum Stopping Sight Distance (ft) Downgrade -3%	Minimum Stopping Sight Distance (ft) Level 0%	Minimum Stopping Sight Distance (ft) Upgrade +3%	Minimum Stopping Sight Distance (ft) Upgrade +6%	Minimum Stopping Sight Distance (ft) Upgrade +9%
20	125	125	125	125	125	125	125
25	175	175	175	150	150	150	150
30	225	225	225	200	200	200	200
35	300	275	275	250	250	250	225
40	400	375	350	325	300	300	300
45	475	450	425	400	375	350	350
50	600	550	500	475	450	425	400
55	700	625	575	550	525	500	475
60	825	750	700	650	600	575	550

Notes:

1. Taken in part from AASHTO, A Policy on Geometric Design of Highways and Streets, 1990.
2. Measured along the center of the approaching travel lanes, as observed from a point twelve (12) feet back from the edge of traveled way, and measured from an eye height of three and one-half (3.5) feet to an approaching object height of four and one-quarter (4.25) feet.]

12.11.3 Street Crown. The normal street crown will be two percent (2%) from the centerline to the lip of gutter, with a minimum of one percent (1%) and a maximum of four percent (4%). The crown will be at the centerline of the traveled way. The street asphalt concrete contact with the lip of the concrete gutter will be three-eighths ($\frac{3}{8}$) inches higher than the elevation of the lip of the gutter unless incorporated as part of a bike lane.

12.11.4 Vertical Curves. Vertical curves will be provided wherever the algebraic difference between two (2) intersecting grades is two percent (2%) or more, excluding intersections. Vertical curves will be of sufficient length to provide the minimum sight and stopping distances as established by AASHTO.

12.11.5 Horizontal Curves. Horizontal curve radii, sight distances, maximum allowable side friction, and maximum allowable superelevation will be determined in accordance with the requirements of "A Policy on Geometric Designs of Highways and Streets," by AASHTO and Tables 12.4 and 12.5. In no case will the centerline curve radius be less than one hundred fifty feet (150').

**Table 12.4
Horizontal Curve Criteria for Arterial Street**

Design Speed	30-45 mph
Maximum Superelevation	4%
Normal Crown	-2%

Minimum Centerline Radius (feet)

Design Speed	-2% Crown	+2% Super	+3% Super	+4% Super
30	460	265	350	330
35	640	500	475	450
40	850	660	625	595
45	1080	820	770	730

**Table 12.5
Horizontal Curve Criteria for Collector Street**

Design Speed	Rural 30-40 mph
	Urban 25-35 mph ¹
Maximum Superelevation	4%
Normal Crown	-2%

Minimum Centerline Radius (feet)

Design Speed	-2% Crown	+2% Super	+3% Super	+4% Super
30	330	240	225	215
35	440	345	330	310
40	620	480	455	430
45	835	640	605	575

Notes: Superelevation not allowed in urban areas. See section 12.12.5.

12.11.6 Broken-Back Curves. Broken-back curves (having a short tangent between two (2) curves in the same direction) will not be allowed. A compound curve alignment will be used to eliminate the need for a short tangent section between curves. Design of compound curves will comply with "A Policy on Geometric Designs of Highways and Streets," by AASHTO.

12.11.7 Median Openings. The design of median openings will be subject to the requirements and approval of the city including storage lengths and tapers to AASHTO requirements.

12.11.8 Intersection Angles. A street or highway intersecting with another street or highway, will intersect as near to a ninety (90) degree angle as is practicable, but in no event will an intersection be allowed at an angle of less than sixty (60) degrees.

12.11.9 Private Streets. Private streets will be designed to meet city standards for local streets, including street lights, storm drain systems, water systems, sanitary sewer systems, and paving structural section.

12.11.10 Asphalt Concrete Structural Sections. Design of the structural section for asphalt concrete pavement will conform to the Asphalt Institute Manual Series No. 1 (MS-1) or an alternate approved by the ~~[city engineer.]~~ **City Engineer.** Inputs to the design procedure will be developed in accordance with the following:

1. Streetbed Soil. Streetbed soil testing will be performed to determine the design streetbed soil resilient modulus, M_r , for use in the design charts, where existing soils data does not exist. The design streetbed soil resilient modulus, M_r , will be determined from test results from the resistance (R) value or California bearing ratio (CBR) tests. Correlations between resilient modulus, M_r , and the resistance (R) value or California bearing ratio (CBR) will be in accordance with the AASHTO "Guide for Design of Pavement Structures." Sufficient tests will be made to evaluate each different soil type in the project. If significant streetbed soil variation is present, sufficient tests will be made to determine the controlling (weakest) soil type, or the limits and boundaries of each streetbed soil type. The design streetbed soils resilient modulus, M_r , will be based on the results of R value or CBR tests, and will be determined as a function of the design traffic level, using lower design values when higher traffic levels exist. Percentile design values (select the design modulus such that X percent of all test values are less than the design modulus) for various traffic levels will not be less than the following:

Design Traffic Level Cumulative ESAL's Over the Design Period	Minimum Percentile Design Value (X)
<10,000	60
10,000 to 1,000,000	75
>1,000,000	87.5

2. Traffic. Site specific traffic data or projections will be used to determine the number of equivalent eighteen thousand (18,000) pound equivalent single axle load (ESAL) applications for the design period. The vehicle types and volumes will be based on the results of a traffic study and will include construction vehicles that will traffic the street during construction of the development or project. ESAL factors will be selected from the Asphalt Institute MS-1 or the AASHTO "Guide for Design of Pavement Structures" for a terminal serviceability index of 2.0. An annual growth rate of not less than four percent (4%) will be used for the design period unless the street is a cul-de-sac or is within a closed service area with no potential for future growth. Design period will be twenty (20) years.

The worksheet for calculating eighteen thousand (18,000) pound ESAL's and the traffic growth rates shown in Tables 12.6 and 12.7 respectively, will be used to determine the design ESAL applications. If the calculated design ESAL based on site specific data or projections is less than five thousand (5,000), a design ESAL of five thousand (5,000) will be used. Generic traffic estimates or guidelines for estimating ESAL's based on street classification will not be used.

Site specific traffic data or projections are not required for local streets that serve less than ten (10) residential units. These streets may be designed using a design ESAL of not less than five thousand (5,000).

3. Thickness Design. Thickness design of asphalt concrete pavements will be based on the Asphalt Institute MS-1 or approved alternative. In no case will the structural section for asphalt concrete pavements be less than that shown in Table 12.8.
 4. Material Determination. Asphalt concrete pavement mix will be Type 2 or Type 3 as shown in Table 12.8 in conformance with the "Standard Specifications for Public Works Construction."
- 12.11.11 Cul-De-Sacs and Knuckles. Minimum grades around cul-de-sacs and knuckle-type intersections will be one-half percent (0.5%). The normal street crown with such a development may be increased to a maximum of four percent (4%) from the centerline to the lip of gutter.
- 12.11.12 Temporary Cul-De-Sacs. Temporary cul-de-sacs will be constructed with a minimum of six inches (6") of aggregate base located within the development. When located within an adjacent future developable area it will conform to temporary emergency access street standards within an access easement.
- The minimum radius of the turnaround will be forty-five feet (45') when measured from the radius point to face of curb or edge of pavement where no curb is present.
- 12.11.13 Emergency Access Streets. Permanent and temporary emergency access streets will have a minimum surface width of twenty feet (20'). Grades will not exceed the maximum street grades. Access to street at each entrance will be controlled by an "Emergency Access Control Gate," and will be posted "For Emergency Access Only."

Table 12.6
 Example Table for Calculating
Design ESAL by Vehicle Class (7)

	Analysis Period = _____ Years
Location _____	Assumed SN or D = _____

Vehicle Types	Current Traffic (A)	Growth Factors (B)	Design Traffic (C)	ESAL Factor (D)	Design ESAL (E)
Passenger Cars Buses					
Panel and Pickup Trucks					
Other 2-Axle/4-Tire Trucks					
2-Axle/6-Tire Trucks					
3 or More Axle Trucks					
All Single Unit Trucks					
3 Axle Tractor Semi-Trailers					
4 Axle Tractor Semi-Trailers					
5+ Axle Tractor Semi-Trailers					
All Tractor Semi-Trailers					
5 Axle Double Trailers					
6+ Axle Double Trailers					
All Double Trailer Combos					
3 Axle Truck-Trailers					
4 Axle Truck-Trailers					

5+ Axle Truck-Trailers					
All Truck-Trailer Combos					
All Vehicles				Design ESAL	Design ESAL

Notes:

1. Column A is the daily volume count of each vehicle type taken from data collected at classification count stations representative of the design location, for the base year.
2. Column B contains the growth factor assigned to each class of vehicle as taken from Table [8.7.] **12.7** This accounts for the fact that not all vehicles will increase at the same rate.
3. Column C is the product of Column A times Column B multiplied by three hundred sixty-five (365) days to produce the accumulated applications of specific vehicle types during the analysis period.
4. Column D is the individual ESAL factor for each truck type (truck load factor) as taken from the Asphalt Institute MS-1 or the AASHTO "Guide for the Design of Pavement Structures."

Table 12.7
Traffic Growth Factors(7)

Analysis Period Year(s)	No Growth	Annual Growth Rate, Percent (g) 2	Annual Growth Rate, Percent (g) 3	Annual Growth Rate, Percent (g) 4	Annual Growth Rate, Percent (g) 5	Annual Growth Rate, Percent (g) 6	Annual Growth Rate, Percent (g) 7	Annual Growth Rate, Percent (g) 8
1	1.0	1.0	1.0	1.0	1.0	1.0	1.0	1.0
2	2.0	2.02	2.03	2.04	2.05	2.06	2.07	2.08
3	3.0	3.06	3.09	3.12	3.15	3.18	3.21	3.25
4	4.0	4.12	4.18	4.25	4.31	4.37	4.44	4.51
5	5.0	5.20	5.31	5.42	5.53	5.64	5.75	5.87
6	6.0	6.31	6.47	6.63	6.80	6.98	7.15	7.34
7	7.0	7.43	7.66	7.90	8.14	8.39	8.65	8.92
8	8.0	8.58	8.89	9.21	9.55	9.90	10.26	10.64
9	9.0	9.75	10.16	10.58	11.03	11.49	11.98	12.49
10	10.0	10.95	11.46	12.01	12.58	13.18	13.82	14.49
11	11.0	12.17	12.81	13.49	14.21	14.97	15.78	16.65
12	12.0	13.41	14.19	15.03	15.92	16.87	17.89	18.98
13	13.0	14.68	15.62	16.63	17.71	18.88	20.14	21.50
14	14.0	15.97	17.09	18.29	19.16	21.01	22.55	24.21
15	15.0	17.29	18.60	20.02	21.58	23.28	25.13	27.15
16	16.0	18.64	20.16	21.82	23.66	25.67	27.89	30.32
17	17.0	20.01	21.76	23.70	25.84	28.21	30.84	33.75
18	18.0	21.41	23.41	25.65	28.13	30.91	34.00	37.45
19	19.0	22.84	25.12	27.67	30.54	33.76	37.38	41.45
20	20.0	24.30	26.87	29.78	33.06	36.79	41.00	45.76
25	25.0	32.03	36.46	41.65	47.73	54.86	63.25	73.11
30	30.0	40.57	47.58	56.08	66.44	79.06	94.46	113.28
35	35.0	49.99	60.46	73.65	90.32	111.43	138.24	172.32

Notes:

1. Factor = $[(1 + g)n - 1]/g$, where $g = \text{rate}/100$ and is not zero. If annual growth rate is zero, the growth factor is equal to the analysis period.
2. The above growth factors multiplied by the first year traffic estimate will give the total volume of traffic expected during the analysis period.

**[Table 12.8
Type of Asphalt Concrete Pavement Required**

Functional Classification	Type of Asphalt Concrete Pavement	Minimum AC Thickness (inches)	Minimum Base Thickness (inches)	Type of Surface Seal ²
Arterial	Type 2	A. ⁺	A. ⁺	Fog Seal
Collector	Type 2	4	8	
Industrial Street	Type 2	4	8	
Local Street	Type 3	3	6	

Notes:

1. ~~All existing arterial streets in Carson City are maintained under the jurisdiction of the Nevada Department of Transportation. Design of arterials will be currently coordinated with the Nevada Department of Transportation and comply with their requirements.~~
2. ~~Within a period of not more than twenty (20) days after asphalt concrete pavement has been placed, a fog seal will be applied to the asphalt concrete pavement in accordance with the requirements of the "Standard Specifications for Public Works Construction."~~

Temporary and permanent emergency access streets will be structurally designed to support a tandem axle loading of twenty-five (25) tons. In no case will temporary emergency access streets be surfaced with less than six inches (6") of Type 2, Class B Aggregate Base applied with a minimum one-half (0.5) gallons per square yard of magnesium chloride and be provided with adequate streetside drainage. Emergency access streets will be provided with adequate streetside drainage.

12.11.14 Improved Maintenance Access. Vehicular access for maintenance of sanitary sewer, water system, and storm drain facilities and their related appurtenances will be constructed to a minimum width of twelve feet (12'), **and** be provided with adequate street ~~drainage.] **drainage or as otherwise required by the utility.**~~

Temporary and permanent maintenance access will be structurally designed to support a tandem axle loading of twenty-five (25) tons. In no case will maintenance access streets be surfaced with less than ~~six inches (6")~~ **3 inches** of **asphalt cement with 3 inches** Type 2, Class "B" aggregate base.

12.11.15 Retaining Walls. Retaining walls will be reviewed by the Carson City building division and will be subject to their design criteria.

12.11.16 Signs. Street name signs will be installed at all intersections. Hazard markers and hazardous condition signs will be installed to mark obstructions within or adjacent to the roadway clear zone. The clear zone will have a minimum width of ten feet (10') beyond the edge of pavement where no curb is present and one and one-half (1.5) feet beyond the face of curb. Signage will be installed on all newly constructed or improved public streets and bikeways within or adjacent to the development, as required by approved improvement plans. Signs and pavement markings will conform with the

MUTCD, and the Standard Street Sign detail in Appendix A. Stop signs will be [high] **prismatic** intensity sheeting and be thirty inches (30") in size.

Proposed signage layouts will be submitted with public improvement plans. A list of traffic signs and regulatory traffic control devices installed as part of the project, will be submitted with the improvement plans. The list of traffic control devices will be submitted in the format shown in Table 12.10.

12.11.17 Pavement Markings. Pavement markings will be installed for all improvements in accordance with the recommendations of the traffic [report,] **impact study**, or as required by the approved improvement plans. Proposed pavement marking layouts will be included in the improvement plans. Crosswalk markings will be installed at all traffic signal locations, and at other locations as recommended in the traffic report. Stop bars will be provided at all STOP sign locations and include the word 'STOP.' Pavement markings will conform with the Manual of Uniform Traffic Control Devices (MUTCD). Striping materials and application will conform the "Standard Specifications for Public Works Construction."

12.11.18 Street Shoulders. Shoulders will be constructed on all streets that do not have curb and gutter. Minimum shoulder widths will be shown in Table [~~12.9.~~] **12.9, as measured from the edge of the traveled way**. Paved shoulders will have a cross-slope of two percent (2%) to four percent (4%), gravel shoulder will have a cross slope of four percent (4%) and will drain away from the traveled way. Unpaved shoulders will have a minimum of six inches (6") of Type 2, Class B aggregate base in accordance with the "Standard Specifications for Public Works Construction." Paved shoulders will have the same structural section as the street.

**Table 12.9
Shoulder Width Requirements**

Street Classification	Arterial	Collector	Industrial	Local
Shoulder Width	[N/A] 8-ft	8-ft. minimum	8-ft. minimum	4-ft. minimum
<u>Paved Shoulder Width</u>	<u>8-ft</u>	<u>4-ft minimum</u>	<u>4-ft minimum</u>	<u>1-ft minimum</u>

12.11.19 Roadside Hazards. Non-breakaway street hazards will not be located within the street clear zone area. Objects considered non-breakaway street hazards are those that do not yield or separate upon vehicular impact. The clear zone area is defined as follows:

1. Streets with vertical barrier curb of at least six inches (6") in height, will not have objects of non-breakaway nature located closer than two feet (2') to the face of curb.
2. Streets without at least six inches (6") of vertical barrier curb and with posted speeds of thirty-five (35) mph or less will not have objects of non-breakaway nature located closer than ten feet (10') to the edge of the traveled way.
3. Streets without at least six inches (6") of vertical barrier curb, and with posted speeds greater than thirty-five (35) mph will have their clear zone areas determined by the city.

Table 12.10
 Example Format for Regulatory
 Traffic Control Device Listing

Sign Located On:	At Intersection of:	Sign Type/Description	MUTCD Sign Code	Sign Faces	Side of Road	Direction from Int. to Sign	Distance from Intersection to Sign
		Stop	R1-1	N	W	N	0 feet
		Speed	R2-1	E	N	W	50 feet
		Limit 15	R1-1	W	S	W	20 feet
		mph	R1-1	N	W	N	10 feet
		Stop	R1-1	W	S	W	20 feet
		Stop	R1-1	N	W	N	10 feet
		Stop	R1-1	S	E	S	10 feet
		Stop	R2-1	E	N	W	50 feet
		Stop	R1-1	SW	E	SW	0 feet
		Speed	R1-1	SW	E	SW	0 feet
		Limit 15					
		mph					
		Stop					
		Stop					

SECTION XXXX:

That Title 18 Appendix (CARSON CITY DEVELOPMENT STANDARDS), Division 12 (TRANSPORTATION), Section 12.12 (Sidewalks, curb and gutter, driveway approaches, curb-cuts, alleys and bikeways) is hereby amended (**bold, underlined** text is added, [~~stricken~~] text is deleted) as follows:

12.12 Sidewalks, curb and gutter, driveway approaches, curb-cuts, alleys and bikeways.

12.12.1 Sidewalks. [~~In no instance will sidewalks~~] **Sidewalks may not** be less than [~~five feet (5')~~] **5 feet** in width [~~(not), not including curb and (gutter).~~] **gutter, in any circumstance.** In areas where handrails encroach upon the sidewalk, the sidewalk [~~will~~] **must** be widened to provide a minimum [~~five foot (5') clear width.~~] **clear width of 5 feet.**

12.12.2 Residential Driveway Access. Driveway access [~~will be allowed~~] **must be made** in accordance with Table 12.11. Design and construction for driveway approaches and curb-cuts [~~will be in accordance~~] **must be consistent** with [~~city~~] **City** standards. All residential driveway approaches [~~will~~] **must** enter properties via a standard curb-out. [~~No curb~~] **Curb** returns [~~are permitted~~] for residential approaches or [~~access.~~] **or access are prohibited.** Driveway grades [~~will~~] **may** not exceed [~~fourteen percent (14%).~~] **14 percent.** Driveway alignment must be safe and convenient [~~to back a car out, or~~] **for a vehicle to drive in reverse unless** an adequate turn-around [~~will be~~] **is** provided. Residential driveways [~~will~~] **must** have a minimum width of [~~twelve feet (12')~~] **12 feet** and a maximum **cumulative** width of [~~twenty-seven feet (27').~~] **36 feet. Residential driveways must have a minimum**

length of 20 feet if on-street parking is not provided. Residential driveways must have a minimum length of 5 feet if on-street parking is provided. Driveway width [will] **and length must** be measured at the back of walk. Driveways [will] **must** be constructed of Portland cement concrete in [urban areas,] **areas requiring the “Roadway Section Urban Streets” detail as set forth in the Carson City Standard Details for Public Works Construction that is used by the Development Engineering Division of the Department,** and Portland cement concrete or asphalt concrete **must be used for the first 360 feet in** [rural areas. Alternative] **areas requiring the “Roadway Section Rural Roads” detail as set forth in the Standard Details for Public Works. Pavers may only be used outside of the right-of-way, including the apron or sidewalk. A driveway must be constructed of not less than 6 inches of compacted aggregate base where the driveway will enter an unpaved street. The use of alternative** materials must be approved by the [city.] **City Engineer. If a secondary driveway must be paved for an accessory structure that is not used as a dwelling, the driveway is only required to be paved for the first 20 feet measured from the right-of-way.**

The use of any type 2 curb and gutter or rolled curb in a public right-of-way must be approved by the Board of Supervisors. Gutter or rolled curb may be used on privately owned streets that are maintained by a homeowners’ association or similar entity.

- 12.12.3 Commercial Driveways. Spacing from center to center of driveways will comply with the requirements of Table 12.12. Driveways will be located no closer to intersections than indicated in Table 12.13, or as required to provide for left turn bays. The minimum intersection corner clearance as indicated in Table 12.13 will be measured from the intersection of the right-of-way lines to the center of the driveway. Commercial driveways will have a minimum width of fifteen feet (15') for one-way traffic and thirty feet (30') for two-way traffic. Commercial driveways will have a maximum width of thirty-four feet (34') for light commercial traffic and fifty-four feet (54') for heavy commercial and industrial traffic. Driveway width will be measured at the back of walk. Commercial driveways will be constructed of Portland cement concrete. Alternative materials must be approved by the city.
- 12.12.4 Car Storage Access. Where car storage or access for recreational motor vehicles is desired in residential, business, commercial, or industrial areas, provisions will be made for a driveway.
- 12.12.5 Pedestrian Ramps. Curb returns at street intersections, and other locations as recommended by the Americans with Disabilities Act, will be provided with pedestrian ramps for the handicapped in accordance with the standard details. [~~Single (i.e., diagonal or depressed corner) sidewalk curb ramps serving two (2) street crossing directions are not permitted (i.e., all ramps will be constructed perpendicular to the street to be crossed).~~] Pedestrian ramps will be constructed in accordance with the Americans with Disabilities Act.
- 12.12.6 Curb and Gutters. Curbs and gutters are to be constructed of Portland cement concrete in accordance with the standard details.

12.12.7 Radii at Street Intersections. At each right angle street intersection, the right-of-way line and/or road easement line at each block corner will follow the cord of a curve having a radius of not less than fifteen feet (15') on local streets, twenty feet (20') on collector streets, and thirty-five feet (35') on arterial streets.

**Table 12.11
Driveway Access**

Access to Functional Classification	Land Use Designation SFR	Land Use Designation MFR	Land Use Designation C	Land Use Designation I	Land Use Designation PF	Land Use Designation CR/A
Local Street	P	P	PI	P	PI	P
Collector Street	P	PS	PI	P	PI	P
Industrial Street	P	P	P	P	P	P
Arterial Street	PS	PS	PR/PI	PR/PI	PR/PI	PS

Index

P	Driveways Permitted
PS	Permitted by Public or Private Streets only
PR	Driveways Permitted, number and distance between driveways restricted
PI	Driveways Permitted, distance from intersecting streets based on projected left turn volumes to intersecting street

Land Use Designation	Abbreviation
Single Family Residential (All)	SF
Multiple-Family Residential	MFR
Commercial (All)	C
Industrial (All)	I
Community or Public Facilities	PF
Open Space/Conservation Reserve	CR
Agriculture	A

**Table 12.12
Required Spacing Between Driveways**

Street Classification and Posted Speed Limit	Center to Center Spacing Between Driveways (feet) Preferred	Center to Center Spacing Between Driveways (feet) Minimum
Arterial Street		
30 mph speed limit	185	125
35 mph speed limit	245	150
40 mph speed limit	300	185
Collector Street		
30 mph speed limit	185	125
35 mph speed limit	245	150
40 mph speed limit	300	185
45 mph speed limit	350	230
Industrial Street	50	50
Local Street	50	50

Table 12.13
 Minimum Intersection Corner
 Clearance for Commercial Driveways

Street Classification	Minimum Intersection Corner Clearance ³ (feet) Signalized Condition	Minimum Intersection Corner Clearance (feet) Stop Sign Condition
Arterial Street	230 ¹	150
Collector Street	175 ¹	85
Industrial Street	175 ¹	85
Local Street	175 ²	85

Notes:

1. Where intersections are unsignalized but may be signalized in the future, the minimum corner clearance for signalized intersections will be used.
2. Where intersections on local streets are unsignalized, the minimum corner clearance for signalized intersections will be used.
3. As measured from the intersection of the right-of-way lines, or extension thereof in the case of rounded returns, to the center of the driveway.

Where streets intersect at angles of less than right angles or where other peculiar conditions of intersection occur, the city may require a different radius.

12.12.8 Curb Returns. Curb returns [~~will~~] **must** have minimum face of curb radii of [~~fifteen feet (15') on urban local streets (fifteen feet (15') on rural local streets), thirty feet (30') on urban collector streets (thirty feet (30') on rural collector streets), thirty feet (30') on minor arterial streets, and forty feet (40') on major arterial streets.~~] **15 feet at the intersection of two local streets, 30 feet at the intersection of any collector street and 40 feet at the intersection of any arterial street.** Curb returns [~~will~~] **must** be used at commercial [~~driveways. Curb returns will not be allowed at residential driveways.~~] **driveways and must be a minimum of 20 feet. Curb returns in residential driveways are prohibited. Curb returns measuring less than the minimum radii set forth in this subsection may be authorized only upon approval by the City Engineer.**

12.12.9 Bicycle Lanes and Bicycle Routes. The design of bicycle lanes, bicycle routes, and bicycle paths will conform to the AASHTO "Guide for Development of Bicycle Facilities," city ordinance, "Standard Specifications for Public Works Construction," and this section. Bicycle lanes and bicycle routes will be constructed at locations designated in the transportation element of the master plan.

The minimum width for bicycle lanes on roadways where on-street parking is prohibited will be four feet (4') as measured from the edge-of-pavement where curbs and gutters are not present and five feet (5') as measured from face-of-curb where curbs and gutters are present.

12.12.10 Bicycle and Pedestrian Paths. The design of bicycle and pedestrian paths will conform to the AASHTO "Guide for Development of Bicycle Facilities," bicycle section of the transportation plan, city ordinances, "Standard Specifications for Public Works

Construction," and this section. Bicycle and pedestrian paths will be constructed at locations designated in the master plan.

The minimum width for two-directional bicycle and pedestrian paths shall be ten feet (10'). All bicycle and pedestrian paths will be designed as two-directional facilities. All bicycle and pedestrian paths will have a minimum two-foot wide graded shoulder which consists of a minimum of [~~four inches (4")~~] **6 inches** of type 2 class B aggregate base.

The structural section for these facilities [~~shall~~] **must** be based on a soils engineering report recommendation unless waived by the [~~city engineer~~] **City Engineer**. The minimum structural section for paths [~~shall be two inches (2")~~] **is 2 inches** of asphalt concrete, [~~AC-20~~] **PG64-28NV** using type 3 aggregate with fog seal over four inches [~~(4")~~] **6 inches** of type 2, class B aggregate base.

12.12.11 Obstructions. Obstructions shall not be located at intersections or other locations, such as driveways, that interfere with sight distance.

Obstructions such as power poles, pull boxes, mail boxes, pedestals, transformers, and telephone boxes shall be placed in easements adjacent to the right-of-way. Where obstructions exist in areas of proposed improvements, it shall be the responsibility of the developer to relocate existing obstructions out of sidewalk and pedestrian areas, and other areas of improvements.

12.12.12 Cut and Fill Slopes. Cut and fill slopes shall be set back a minimum of two feet (2') from the back of the sidewalk. If no sidewalk exists the setback shall be a minimum of seven feet (7') from back of curb. Back of curb drainage shall be installed as necessary. The right-of-way and/or slope easement shall extend at least two feet (2') beyond where the natural surface of the ground must be excavated or covered with fill dirt or materials in constructing cuts, fills, curb and gutter, sidewalk, and drainage improvements.

12.12.13 Alleys. Alleys required to serve a development shall be improved and conform to city standards. Alleys shall have a minimum right-of-way width of twenty-five feet (25'), minimum pavement width of twenty feet (20'), and comply with city drainage requirements.

12.12.14 Alley Grades. Longitudinal grades shall conform to standards for streets, with a cross slope of two percent (2%) minimum from the property line toward the center of the alley. Alleys shall be an inverted crown and if the longitudinal grade is less than one and nine-hundredths percent (1.09%) than a concrete valley gutter shall be provided.

SECTION XXXX:

That Title 18 Appendix (CARSON CITY DEVELOPMENT STANDARDS), Division 12 (TRANSPORTATION), Section 12.13 (Traffic and impact study requirements) is hereby amended (**bold, underlined** text is added, [~~stricken~~] text is deleted) as follows:

12.13 Traffic [~~and~~] impact study requirements.

12.13.1 General. Traffic [~~engineering and~~] impact studies are required for the purpose of analyzing the impacts of development or improvement on the existing transportation

system. The transportation system is composed of primarily surfaced streets, but also includes elements such as pedestrian paths, bike paths and lanes, bus routes, highways or other means of transportation. Traffic ~~[engineering studies shall]~~ **impact studies** be prepared and submitted to the city to identify and mitigate traffic impacts of development activity. ~~[All traffic studies for proposed development on now vacant land shall be prepared based on Carson City master plan land uses and densities.]~~

Traffic engineering studies shall be presented in written format, accompanied by appropriate drawings, plans, or maps needed to clearly present the material. The study shall clearly list all assumptions and criteria upon which the analysis is based. All references shall be listed by author, publications, name and date. Traffic engineering studies are] **All proposed development must be reviewed to identify and determine the level of potential impact to the existing transportation network. A traffic impact study is** required if one or more of the following conditions are met:

1. The proposed development ~~[shall generate eighty (80)]~~ **will generate 80** or more peak hour trips as determined using the Institute of Traffic Engineers (ITE) trip generation rates or other such sources accepted by the ~~[city engineer.]~~ **City Engineer.**
2. The proposed development ~~[shall]~~ **will** generate ~~[five hundred (500)]~~ **500** or more trips ~~[per]~~ **each** day.
3. The proposed development **is an addition, a significant tenant improvement or** contains phasing, and **the cumulative** impacts from the ~~[cumulative phasing have net effects of items 1 or 2. In this case,]~~ **development results in a net effect of the circumstances described in paragraphs 1 or 2 of this subsection, in which case** a traffic study ~~[shall be required]~~ **must be prepared** with the first phase of the development. **Traffic impact study requirements for small tenant improvements may be waived by the City Engineer if it is anticipated that any traffic impact resulting from the improvement will be similar to or less than the existing use.**
4. The ~~[city engineer determines that]~~ **City Engineer shall determine whether** a traffic study is required. For example, a traffic ~~[engineering]~~ **impact** study may be required for small developments that do not satisfy one of the above requirements if they are near a school, community shopping or recreation area, near a historic area, **in an area of congestion or high vehicle crash rate** or ~~[shall]~~ **will** generate truck traffic. ~~[On]~~ **For** small developments, the ~~[city]~~ **City** may require an analysis of the **number and type of trips that will be generated**, proposed access, safety ~~[issues,]~~ **issues** and the internal street system or parking.
5. The proposed development contributes to the need for a traffic ~~[signal.]~~ **control device, including a traffic signal, roundabout, stop sign, median control, electronic pedestrian controller, a flashing beacon or other regulatory device that is located along or within the roadway and which is intended to control the flow of vehicular traffic.**

All traffic impact studies must be made in writing and accompanied by appropriate drawings, plans or maps that are necessary to clearly present the findings. Any such study must clearly identify all assumptions and criteria upon which the analysis is based. Any

references to other materials must be identified by the name of the author and the date and title of the publication.

12.13.2 Scope of Work and Method. The [city] **City** shall approve the scope of work and method of analysis [~~prior to~~] **before** the start of any traffic [engineering] **impact** study. For all projects, a scoping meeting with the [city shall] **City must** be conducted [~~prior to~~] **before** the start of any traffic [engineering] **impact** study. **The scoping meeting must include, at a minimum, the following topics for discussion:**

1. The proposed location and construction schedule for the development.

2. Preliminary plans or sketches of the proposed development showing streets or other points of access.

3. The level of analysis to be required of the study.

4. An identification of the study area which must include all portions of the transportation network that the City determines may be affected by the development, including, without limitation, roadway segments, intersections and driveways to be analyzed by the study, and all roadway segments and intersections of the surrounding transportation system.

5. An identification of the long-term horizon year.

All traffic [engineering] **impact** studies [shall] **must** be prepared [by,] **by** or under the direct supervision [of,] **of** a professional engineer **who is** licensed in Nevada [with] **and has** adequate experience in transportation or traffic engineering. [~~The study area shall include all portions of the transportation network that the city or the traffic engineer believe may be affected by the project. The analysis shall include all segments and intersections of the surrounding transportation system.~~]

12.13.3 Traffic [Engineering] **Impact** Study Requirements. In reviewing the scope of work proposed by [the] **a** consultant for [the] **any** traffic [engineering] **impact** study, the criteria in the following [sections shall] **subsections must** be considered by the [city:] **City for inclusion in the study.**

12.13.3.1 Previous Traffic Studies. Applications [shall] **must** include a [copy(ies)] **copy** of **any** previously approved [studies] **study** applicable to the project or referenced in the new study. If a previously approved traffic [engineering] **impact** study exists for a portion of the study limits, then an analysis of the differences in results shall be included as part of the scope of the current traffic [engineering] **impact** study. Simply referencing previous studies shall not be sufficient.

12.13.3.2 Master Plan, Zoning [~~and/or~~] **or** Tentative Map Applications. The traffic [~~engineering study shall~~] **impact study must** be based on the Carson City master plan designations, zoning [~~and/or~~] **or** tentative map configurations, at the maximum allowable densities and uses.

12.13.3.3 Scope of Traffic [Engineering] **Impact** Study. A sample table of contents for a traffic [engineering study report] **impact study** is shown in Table [~~12.15. The~~] **12.14. Except as otherwise specifically modified by the City, a** traffic [engineering] **impact** study [~~shall include the following items as a minimum:]~~ **must contain, at a minimum, the following:**

1. [~~Project Description.~~] **A description of the project.**
 - a. Include site plans and location maps.
 - b. Describe and quantify the existing and proposed land uses and zoning, development intensities, and uses of the project site as follows:
 - (1) Existing Conditions: The traffic [~~engineering study shall~~] **impact study must** generate traffic volumes based on the existing land uses and densities based on existing street and transportation configurations. This shall be the basis for further comparison of the proposed project impacts on the existing transportation system. The existing traffic loading shall be based on current traffic counts, either conducted specifically for this study, or as approved by the city.
 - (2) Existing Conditions Plus Project: The traffic [~~engineering study shall~~] **impact study must** generate traffic volumes based on the existing land uses and densities plus the proposed project land uses and densities based on the existing street and transportation configurations. This shall indicate the amount to which the project shall impact the existing transportation system.
 - (3) Long-Term Transportation Model: The traffic [~~engineering study shall~~] **impact study** generate traffic volumes based on the existing land uses and densities, and city approved projects in the study area. This shall indicate the amount to which this project and all other proposed future projects shall cumulatively impact the existing transportation system.
 - c. Discuss the project phasing and timing of proposed and anticipated future development.
 - d. Submit site plans [~~which shall~~] **that** include the location, separation distance, and number of proposed driveways and intersections. Include all existing and proposed **local**, collector, arterial, and [~~expressway~~] **freeway** facilities through and within three hundred feet (300') of the project.
 - e. Describe the relationship of all access points to the transportation network including separation distance. The descriptions shall include existing driveways and intersections within three hundred feet (300') from the project site, and all intersections within the project site.
 - f. Describe **existing and proposed** bicycle and pedestrian facilities.
 - g. Discuss existing and proposed public transit service and bus stop improvements.
 - h. Describe all other features that affect traffic flow including crosswalks, school bus stops, and postal cluster boxes.
2. Trip Generation.
 - a. Trip generation **volumes** for average daily trips (ADT), a.m. peak hour trips [~~including~~] **including** in and out traffic [~~split~~], **split**, and p.m. peak hour trips [~~including~~] **, including** in and out traffic [~~split shall~~] **split. For purposes of this provision, peak hour may occur during a midday period. Trip generation must** be based on type and intensity of land use.

- b. Trip generation shall be based on data published in "Trip Generation," by the ITE. If published data, or local trip generation studies are not available, the engineering firm shall obtain approval from the city for estimated trip [~~rates.~~] **rate during scoping.**
 - c. Indicate how peak periods were identified.
 - d. Provide **existing** traffic counts for a typical [~~day; include~~] **day, with school in regular session if the project is located within 2 miles of a school, including** dates, times, and weather conditions. Traffic counts [~~shall~~] **must** not be more than twelve (12) months old.
 - e. Provide traffic volume maps for all roads and intersections.
3. Trip Distribution and Assignment.
- a. Describe trip distribution for a.m. [~~and~~] , p.m. **and midday** peak periods, [~~noon hour,~~] and existing and future scenarios evaluated in the traffic study.
 - b. Describe the methods used to distribute and assign trips.
 - c. Trip distributions and splits shall be approved by the city.
4. Impact Analysis.
- a. Prepare an impact analysis including effects to level of service (LOS) for the affected roads and intersections for the following time periods for the a.m. and p.m. peak hours:
 - (1) Existing conditions without project.
 - (2) Existing conditions plus project (at project buildout).
 - (3) [~~Carson City master plan build-out plus project.~~] **Horizon year as described in the Regional Transportation Plan as adopted by the City, as may be amended.**
 - b. For affected intersections, the "critical movement" method of analysis shall be used. An example of this analysis is provided in Figure 5-8 of the "Traffic Engineering Handbook, 4th Edition," (9).
 - c. Pedestrian movements shall be considered in the analysis.
 - d. Roadway operational characteristics and analysis techniques shall be based on the MUTCD by the Federal Highway Administration, "Guidelines for the Design of Streets and Highways" by AASHTO, and the "Highway Capacity Manual" by the Transportation Research Board.
 - e. Analyze the adequacy of storage space for turning vehicles considering signal phasing, signal length, and traffic volumes.
 - f. Analyze the adequacy of site driveways and internal circulation. Driveway design shall be based on the type of traffic that shall use the driveway and adjacent street. Service vehicle access shall be reviewed and based on the size and operating characteristics of service vehicles, particularly turning radii.

- g. Safety and neighborhood impacts [~~shall~~] **must** be analyzed. Obtain and review traffic accident data for the study [~~area.~~] **area for the immediately preceding 5 years as a minimum.**
 - h. Analyze parking and pertinent site distances.
 - i. Analyze the impact of the project on existing road structures. Analysis shall include:
 - (1) Both the site-generated traffic and the construction traffic associated with the project.
 - (2) An estimate of the total number of equivalent single axle loads (ESALs) generated by the project at completion of the project (including construction traffic), at five (5) years following initiation of construction, and at the year [~~2015.~~] **2050.**
 - (3) An estimate for each affected road, of the remaining life (in both ESALs and years) of the road both with (including construction traffic) and without the project. Non-destructive testing, such as falling-weight deflectometer testing, may be required for this analysis. Carson City shall, upon request, provide available information (if any) for this analysis. The traffic report may require a geotechnical engineering supplement to address traffic impacts.
5. Impacts and Mitigation.
- a. A traffic LOS D or better, in the context of providing a safe, efficient and convenient transportation system, shall be maintained through mitigation of impacts from all conditions on all city maintained arterial, and collector roads and at city road intersections, except as noted in the Carson City master plan. The engineering traffic study shall include recommendations for mitigation of project traffic impacts, including [~~timing~~] **phases** of improvements, **signal timing modifications** and schematic drawings for recommended mitigation.
 - b. The engineer shall determine the feasibility of constructing the mitigation measures. The feasibility analysis is not to be determined from the standpoint of the single project. In the case of existing or master-planned roads through or adjoining the project, recommended mitigation measures shall include dedication of right-of-way and construction of improvements identified in the transportation element of the Carson City master plan, and adopted transportation improvement plan and five (5) year plans.
6. Results.
- a. The traffic [~~engineering study shall~~] **impact study must** be presented in a neat professionally written form. The language used in the traffic study shall be straightforward, clear and concise. Technical terms and jargon, when used shall be kept to a minimum, and shall be clearly defined. Traffic studies shall include executive summaries at the beginning of the report, and technical appendices at the end of the report.
 - b. The engineering traffic study shall further contain the following information:

- (1) Basic Discussion: The traffic [~~engineering study shall~~] **impact study must** be prepared so that minimal reference to other sources of information is required to understand the study results. Tables and figures shall be used where necessary to clearly list and itemize numbers and details of the study assumptions and results.
- (2) Existing Streets and Intersections: The impacts on the existing transportation system, without the proposed improvements shall be clearly explained. This shall be the basis for comparison of the developed conditions. It shall also provide a check against other sources of information such as the transportation element of the Carson City master plan, provide recommendations, based on this analysis of the required improvements needed to meet the Carson City master plan and LOS requirements for traffic capacity at all conditions.
- (3) New Streets and Intersections: The traffic [~~engineering study shall~~] **impact study must** clearly justify the proposed transportation system improvements and show how they meet the Carson City master plan criteria and policies. Additional improvements required to meet the Carson City master plan criteria and policies, not indicated in the original project assumptions and proposal shall be clearly detailed. The financial responsibility for all proposed improvements shall also be clearly detailed. Compare the results of this analysis with the capabilities of the proposed Carson City master plan build-out improvements. Where cost sharing is anticipated, all contributing parties shall be identified and a pro-rata share, both in percentage and dollar amount, shall be provided.

Table 12.14

Sample Table of Contents for Site Traffic [~~Access and~~] Engineering Impact Study Report

- I. Introduction and Summary
 - A. Purpose of Report and Study Objectives
 - B. Executive Summary
 1. Site Location and Study Area
 2. Development Description
 3. Principal Findings
 4. Conclusions
 5. Recommendations (Specific mitigation measures and/or contributions)
- II. Proposed Development (Site and Nearby)
 - A. Summary of Development
 1. Land Use and Intensity
 2. Location
 3. Site Plan
 4. Zoning
 5. Phasing and Timing

- III. Area Conditions
 - A. Study Area
 - 1. Areas of Influence
 - 2. Areas of Significant Impact (may also be part of Division IV)
 - B. Study Area and Land Use
 - 1. Existing Land Uses
 - 2. Existing Zoning
 - 3. Anticipated Future Development
 - C. Site Accessibility
 - 1. Area Road System
 - a. Existing
 - b. Future
 - 2. Traffic Volumes and Conditions
 - 3. Transit Service
 - 4. Existing Relevant Transportation System Management Programs
 - 5. Other as Applicable
 - D. Condition of Existing Roads
 - 1. Structural Section
 - 2. Remaining Pavement Life
- IV. Projected Traffic
 - A. Site Traffic (each horizon year)
 - 1. Trip Generation
 - 2. Modal Split
 - 3. Trip Assignment
 - B. Through Traffic (each horizon year)
 - 1. Method of Projection
 - 2. Non-site Traffic for In Study Area
 - a. Method of Projections
 - b. Trip Generation
 - c. Modal Split
 - d. Trip Assignment
 - 3. Through Traffic
 - 4. Estimated Volumes
 - C. Total Traffic (each horizon year)
- V. Traffic Analysis
 - A. Site Access
 - B. Capacity and Level of Service

- C. Traffic Safety
 - D. Traffic Signals (critical movement analysis and developer prorated share)
 - E. Site Circulation and Parking
- VI. Improvement Analysis
- A. Improvement to Accommodate Base Traffic
 - B. Additional Operational Improvements to Accommodate Site Traffic
 - C. Improvements Needed to Mitigate Road Structural Damage from the Project
 - 1. Damage due to construction traffic
 - 2. Damage due to project-generated traffic
 - D. Alternative Improvements
 - E. Status of Improvements Already Funded, Programmed, or Planned
 - F. Evaluation
- VII. Findings
- A. Site Accessibility
 - B. Traffic Impacts
 - 1. Level of Service on Roads and Intersections
 - 2. Damage to Road Structural Section
 - C. Need for Traffic/Roadway Improvements
 - 1. Operational Improvements (left turn lanes, through lanes, access, etc.)
 - 2. Mitigation of Roadway Structural Damage
 - 3. Traffic Signals and Developer Pro-rata Share
 - D. Compliance with Applicable Local Codes
- VIII. Recommendations **and Conclusions**
- A. Site Access/Circulation Plan
 - B. Roadway Improvements
 - 1. On-Site
 - 2. Off-Site (traffic signal contributions, mitigation of structural damage, operational improvements, etc.)
 - 3. Phasing (if appropriate)
 - C. Transportation System Management Actions
 - 1. Off-Site
 - 2. On-Site Operational
 - 3. On-Site
 - D. Other

~~[IX. Conclusions]~~

SECTION XXXX:

That Title 18 Appendix (CARSON CITY DEVELOPMENT STANDARDS), Division 12 (TRANSPORTATION), Section 12.14 (Street lighting) is hereby amended (**bold, underlined** text is added, [~~stricken~~] text is deleted) as follows:

12.14 Street lighting.

Street lights are required for all developed areas of Carson City. Lighting levels shall be consistent with the appropriate use. Street lights are required to facilitate safe passage of pedestrian, bicycle and vehicular traffic, and to provide for security. Street light applications are based on recommendations from the Lighting Handbook "Illuminating Engineering Society of North America" (IESNA).

12.14.1 Application. The number of street lights, their location, and the lamp wattage will depend on three (3) factors, which are street classification, adjacent zoning, and urban or rural street conditions.

1. Street Classifications. Streets are divided into three (3) classes; arterials, collectors and local streets. Lighting requirements will be greater on arterials, less on collectors, and the least on local streets.
2. Adjacent Zoning. Zoning adjacent to streets will be considered when determining lighting requirements. High use areas will require greater light than large lot rural residential areas. The [~~city engineer will~~] **City Engineer shall** review and approve lighting needs for special districts on a case-by-case basis.
3. Urban and Rural Streets. Urban streets with existing or planned curbs, gutters and sidewalks will require greater lighting than rural streets.

12.14.2 Lamp Size Standards. All lamps [~~shall be high pressure sodium~~] **must be Light Emitting Diode (LED)** unless otherwise approved by the [~~city engineer. Luminaries shall~~] **City Engineer. Luminaries must** be full cut-off unless otherwise approved by the [~~city engineer.~~] **City Engineer.** Lamp size [~~shall~~] **must** be based on the following tables:

**Table A
Traffic Intensity Based on Zoning Designations**

Low Intensity Traffic (LIT)	Medium Intensity Traffic (MIT)	High Intensity Traffic (HIT)
SF12, MH12, PR	SF6, MH6, MHP, RO, GO, NB, CI, MI, HMI, PN, PC	DC, GC, RC, TC

Zones SF5A, SF2A, SF1A, SF21, MH1A, A and CR do not have street lighting requirements.

**Table B
Lamp Sizing**

Street Classification	Adjacent Zoning Intensity Traffic	Urban/Rural Improvements	Lamp Sizes (watts)
Arterial	LIT	Urban/Rural	100
Arterial	MIT	Urban	200
Arterial	HIT	Urban/Rural	200 to 400 ¹

Arterial	MIT	Rural	100
Collector	LIT	Urban	100
Collector	MIT	Urban	200
Collector	HIT	Urban/Rural	200
Collector	LIT	Rural	100
Collector	MIT	Rural	100
Local	LIT/MIT/HIT	Urban/Rural	100

1 Lamp size will depend on width of arterial roadway.

12. 14.3 Light Standards and Placement.

- Light standards shall be Type 7 poles with cobra head fixtures. Arm length and mounting height shall be determined by the application but shall not be greater than shown below. Poles shall be installed one and one-half (1.5) feet behind sidewalks less than eight feet (8') wide unless otherwise approved by the [city engineer.] **City Engineer.** Where sidewalks are greater than eight feet (8') wide, poles shall be installed two and one-half (2.5) feet away from the face of curb. Where streets include a median and off-set sidewalks from the curb, poles shall be installed centered in the median. Pole location for rural streets will depend on street configuration and vehicle speed. Break-away bases may be required when vehicle speeds are greater than thirty-five (35) mph.

**Table C
Pole Heights and Arm Lengths**

Classification	Pole Height (feet)	Arm Length (feet)
Local	25	4
Arterial/Collector	35	12

- Number of Poles at intersections, cul-de-sacs and other locations shall be as shown below.

Traffic Intensity	Intersections	Cul-de-sacs	Post Office Gang Box	Designated Crosswalk or Bike Path crossing
LIT	1	1	1	1
MIT	2	1	1	2
HIT	4	1	1	2

- Preferred design and installation will be a staggered pattern, although for local streets, streetlights may be installed on one (1) side of the street. Street light poles shall be installed at or near property lines and curve returns.

**Table D
Maximum Pole Spacing**

Traffic Intensity	Max. Pole Spacing (feet)	Comment
LIT	zero	Use table above
MIT	230	
HIT	230	

12.14.4 Decorative Street Lighting. Decorative street lighting shall follow the standards for general street lighting with the exception of the full cut-off requirement. Decorative street lighting shall conform to other code requirements related to glare. Maximum pole spacing shall be two hundred thirty feet (230') with a staggered installation. Lighting levels shall meet section 12.14.2 and the desired ambiance for the area of the city. All requests for decorative street lighting shall be approved by the ~~[city engineer]~~ **City Engineer** on a case-by-case basis.

12.14.5 Bike and Pedestrian Paths. Bike and pedestrian paths separated from the street network may be required to receive lighting. The ~~[city engineer]~~ **City Engineer** shall determine the level of use, the importance of connectivity from high use zoning areas or for the public's safety.

12.14.6 Power Conservation. The ~~[city engineer]~~ **City Engineer** may require "part-night" control devices which allow street lights to come on at dusk and turn off after a predetermined number of hours or at a particular time. The use of these devices would be determined on a case-by-case basis and be coordinated by the city engineer with the utility provider.

SECTION XXXX:

That Title 18 Appendix (CARSON CITY DEVELOPMENT STANDARDS), Division 12 (TRANSPORTATION), Section 12.15 (References) is hereby amended (**bold, underlined** text is added, ~~[stricken]~~ text is deleted) as follows:

12.15 References.

The following publications are intended as references for the provisions set forth in this Division, copies of which must be maintained by the Department or the Department of Public Works:

1. "Guidelines for Urban Major Street Design," Institute of Transportation Engineers, Washington, D.C.
2. "A Policy on Geometric Designs of Highways and Streets," American Association of State Highway and Transportation Officials, Washington, ~~[D.C., 1990.]~~ **D.C.**
3. "Manual on Uniform Traffic Control Devices," Federal Highway Administration National Advisory Committee on Uniform Traffic Control Devices, Washington, D.C., U.S. Government Printing ~~[Office, 1988.]~~ **Office.**
4. "Guide for Development of Bicycle Facilities," American Association of State Highway and Transportation Officials, Washington, ~~[D.C., 1991.]~~ **D.C.**
5. "Trip ~~[Generation, 6th Edition,]~~ **Generation,**" Institute of Traffic Engineers, Washington, ~~[D.C., 1987.]~~ **D.C.**
6. "Highway Capacity Manual, Special Report No. 209," Transportation Research Board, Washington, ~~[D.C., 1994.]~~ **D.C.**

7. "Guide for the Design of Pavement Structures," American Association of State Highway and Transportation Officials, Washington, [~~D.C., 1986.~~] D.C.
8. Americans with Disabilities Act, Public Law 101-336.
9. "Traffic Engineering [~~Handbook, 4th Edition,~~] Handbook," Institute of Traffic Engineers, Washington, [D.C., 1992.] D.C.
10. "Manual of Traffic Signal Design," Institute of Traffic Engineers, Washington, D.C., 1991.
11. [~~Pinsof, Susan Anderson and Tern Musser, "Bicycle Facility Planning," Planning Advisory Service Report Number 459, American Planning Association, October 1995.~~]
- 12.] "Roadside Design Guide," American Association of State Highway and Transportation Officials, Washington, [~~D.C., 1996.~~] D.C.

Except as otherwise designated by the City Engineer, all references described in this section that are to be used by the City must be the most current edition.

SECTION XXXX:

That Title 18 Appendix (CARSON CITY DEVELOPMENT STANDARDS), Division 13 (EROSION & SEDIMENT CONTROL), Section 13.1 (Introduction) is hereby amended (**bold, underlined** text is added, [~~stricken~~] text is deleted) as follows:

13.1 Introduction.

Carson City is responsible for developing, implementing and enforcing a program to reduce pollutants, generated from construction activities, from entering the City's municipal storm water conveyance system. This program includes the following:

13.1.1 Erosion & Sediment Control Ordinance, Chapter 12.18 of [~~C.C.M.C.~~] **of title 18 of CCCMC.**

The erosion and sediment control ordinance contains each of the following items:

- Requires any person applying for a permit to develop and submit [~~a~~] **an** Erosion and Sediment Control Plan with their permit application.
- Requires any person who undertakes earth disturbance [~~is~~] **to be** subject to the ordinance.
- States permit requirements and action for failure to complete the work.
- States general erosion and sediment requirements and maintenance.
- States procedure for notification of needed maintenance, enforcements and appeal process.

13.1.2 Program Goals and Objectives.

The erosion and sediment control program minimum requirements will be applied to construction activities that result in land disturbance [~~of greater than or equal to one~~]

~~acre and/or as required elsewhere in code.]~~ **and in accordance with the Carson City Drainage Manual.** Reduction of storm water discharges from construction activity disturbing less than one acre will be included in the program if that construction activity is part of a larger common plan of development or sale that would disturb one acre or more. The objective of this Division is to provide guidance for avoiding adverse stormwater impacts from construction and other activities on downstream resources and on-site storm water facilities. Minimization of storm water flows, prevention of soil erosion, capture of water-borne sediment that has been unavoidably released from exposed soils, and protection of water quality from on-site pollutant sources are all readily achievable when the proper best management practices (BMPs) are planned, installed and properly maintained.

The construction phase of a project is usually considered a temporary condition, which will be supplanted by the permanent improvements and facilities for the completed project. However, construction work may take place over an extended period ~~[of time,]~~ , including several seasons over multiple years. All management practices and control facilities used ~~[in the course of]~~ **during** construction shall be of sufficient size, strength, and durability to readily outlast the longest possible construction schedule and the worst anticipated weather conditions. The goal of a construction storm water pollution prevention plan is to avoid immediate and long-term environmental loss and degradation typically caused by poorly managed construction sites.

Linear projects, such as roadway construction and utility installations, are special cases of construction activities and present their own, unique set of stormwater protection challenges. Many of the BMPs can be adapted and modified to provide the controls needed to adequately address these projects. It may be advantageous to segment long, linear projects into a series of separate units that can apply all necessary controls pertinent to that particular unit in a timely manner.

Soil erosion and the resulting sedimentation produced by land develop impact the environment, damage aquatic and recreational resources and create aesthetic problems. Examples of the impacts of erosion and sedimentation include:

- Natural nutrient rich topsoils are eroded away, making reestablishment of vegetation difficult. Consequently, soil amendments and fertilizers must be applied. A properly functioning soil system is a sustained storm water management mechanism. Vegetation and soil are not effectively sustained unless both are maintained in good condition.
- Siltation fills culverts and storm drains, decreasing capacities and increasing flooding and maintenance frequency.
- Detention facilities fill rapidly with sediment, decreasing storage capacity and increasing flooding.
- Infiltration devices become clogged and fail.
- Sediment in streams and rivers builds more rapidly. Resulting shallow areas become covered by aquatic plants, reducing usability. Increased nutrient loading from phosphorus attached to soil particles and transported to streams

can cause a change in the water pH, algal blooms and oxygen depletion that leads to eutrophication and fish kills.

- Treatment of water for domestic uses becomes more difficult and costly.
- Aesthetically pleasing, clear, clean water is replaced with turbid water in streams and rivers.
- Eroded soil particles decrease the viability of macro-invertebrates and food-chain organisms, impair the feeding ability of aquatic animals, clog gill passages of fish, and reduce photosynthesis.

Successful fish spawning is diminished by sediment-clogged gravel. Sedimentation following spawning can smother the eggs or young fry.

~~[The Carson City Erosion and Sediment Control Ordinance and this]~~ **This** Division on Erosion and Sediment Control follows the requirements instituted by the US Environmental Protection Agency for owner/operators of private and public construction sites. Under the Phase II National Pollutant Discharge Elimination System (NPDES) program all construction site owners/operators of all proposed private and public construction sites that will disturb a total of one or more acres of land are required to obtain coverage under the Nevada Division of Environmental Protection's (NDEP) General Permit. The owners/operators must submit a Notice of Intent (NOI) and develop and implement a Storm Water Pollution Prevention Plan (SWPPP) that identifies the potential storm water pollution sources on the site and how storm water pollution will be prevented. The SWPPP remains on-site during the duration of the project.

3.1.3 Factors Influencing Erosion.

Several factors influence the erosion potential of a site. These factors include:

- Soil characteristics;
- Vegetative cover;
- Topography; and
- Climate.

SECTION XXXX:

That Title 18 Appendix (CARSON CITY DEVELOPMENT STANDARDS), Division 13 (EROSION & SEDIMENT CONTROL), Section 13.2 (Minimum requirements for erosion & sediment control) is hereby amended (**bold, underlined** text is added, ~~stricken~~ text is deleted) as follows:

13.2 Minimum requirements for erosion & sediment control.

The minimum requirements for erosion and sediment control on construction sites are documented through the preparation of a site plan and SWPPP detailing the BMPs that will be implemented, BMPs timing and maintenance responsibility.

An adequate construction SWPPP includes a narrative and drawings. The narrative is a written statement to explain and justify the pollution prevention decisions made for a particular project. [The narrative contains concise information about existing site conditions, construction schedules, and other pertinent items that are not contained on the drawings. The drawing and notes describe where and when the various BMPs should be installed, the performance goals the BMPs are expected to achieve, and the actions to be taken if the performance goals are not achieved.] **The SWPPP identifies the BMPs that will be employed to prevent sediment and pollutants from leaving the site to satisfy the requirements of section 13.5.4 of this Division. The drawing and notes describe where and when the various BMPs should be installed, the performance goals the BMPs are expected to achieve and the actions to be taken if the performance goals are not met. For projects that must obtain coverage under the NDEP General Permit, applicants may submit the SWPPP prepared for the NOI if all of the Carson City erosion and sediment control minimum requirements are addressed in the SWPPP. A step-by-step procedure for preparing and implementing a SWPPP is set forth in section 13.3 of this Division.**

The minimum requirements for the erosion and sediment control measures that must be implemented for [all] projects in Carson City [~~where one or more acres of land are disturbed are listed below. A step-by-step procedure for preparing and implementing a SWPPP is included in Division 13.3.~~]

The SWPPP identifies the BMPs that will be employed to prevent sediment and pollutants from leaving the site, fulfilling the requirements of Division 13.5.4. For those projects that must obtain coverage under the NDEP General Permit, applicants may submit the SWPPP prepared for the NOI provided all of the Carson City erosion and sediment control minimum requirements are addressed in the SWPPP.] **as described in the Carson City Drainage Manual are set forth in this section.**

13.2.1 Minimum Requirement No. 1: Mark Clearing Limits.

1. Prior to beginning land disturbing activities, including clearing and grading, all clearing limits, sensitive areas and their buffers, and trees that are to be preserved within the construction area must be clearly marked, both in the field and on the plans, to prevent damage and offsite impacts.
2. Plastic, metal, or stake wire fence must be used to mark the clearing limits.

13.2.2 Minimum Requirement No. 2: Establish Construction Access.

1. Vehicle Access. Construction vehicle access and exit shall be limited to 1 route if possible.
2. Tracking Sediment. Exit points [shall] **must** be stabilized [with quarry spalls or crushed rock] **using 3 to 6 inch well graded, washed, angular rock at entrance and exit pads leading to paved roads. Rock pads should be a minimum of 20**

feet wide, 50 feet long and 6 inches thick to minimize the tracking of sediment onto public roads.

3. Wheel Wash. Wheel wash or tire baths should be located on-site, if applicable.
4. Clean Public Roads. Public roads shall be cleaned thoroughly at the end of each day. Sediment shall be removed from roads by shoveling or pickup sweeping and shall be transported to a controlled sediment disposal area. Street washing will not be allowed.

13.2.3 Minimum Requirement No. 3: Control Flow Rates.

1. General. Properties and waterways downstream from development sites shall be protected from erosion due to increases in the volume, velocity, and peak flow rate of stormwater runoff from the project site.
2. Downstream Analysis. Downstream analysis is necessary if changes in flows could impair or alter conveyance systems, stream banks, bed sediments or aquatic habitats.
3. BMPs Functional. Stormwater retention/detention facilities shall be constructed as one of the first steps in grading. Detention facilities shall be functional prior to construction of site improvements [~~(e.g. impervious surfaces).~~] **, including the completion of impervious surfaces.**
4. Additional Flow Standards. The City Engineer may require pond designs that provide additional or different stormwater flow control if necessary to address local conditions or to protect properties and waterways downstream from erosion due to increases in the volume or velocity of stormwater runoff from the project site.
5. Permanent Infiltration Ponds. If permanent infiltration ponds are used for flow control during construction, these facilities should be protected from siltation during the construction phase.

13.2.4 Minimum Requirement No. 4: Install Sediment Controls.

1. Natural Vegetation. The native topsoil and natural vegetation shall be retained in an undisturbed state to the maximum extent practicable.
2. Sediment Removal BMPs. Prior to leaving a construction site, or prior to discharge to an infiltration facility, stormwater runoff from disturbed areas shall pass through a sedimentation pond or other appropriate sediment removal BMPs. Runoff from fully stabilized areas may be discharged without a sediment removal BMPs, but must meet the flow control performance standard of Minimum Requirement No. 3. Full stabilization means concrete or asphalt [~~paving; quarry spalls used as ditch lining;~~] **paving, rock-lined ditches** or the use of rolled erosion products, a bonded fiber matrix product, or vegetative cover in a manner that will fully prevent soil erosion. The [~~city engineer~~] **City Engineer** shall inspect and approve areas stabilized by means other than pavement or [~~quarry spalls.~~] **rock stabilization.**

3. BMPs Functional. Sediment ponds, vegetated buffer strips, sediment barriers or filters, dikes, and other BMPs intended to trap sediment on-site shall be constructed as one of the first steps in grading. These BMPs shall be functional before other land disturbing activities take place.
4. Seeding. Earthen structures such as dams, dikes, and diversions shall be seeded **with a seed mix that is approved by the City, which must not contain any invasive species**, and mulched according to the timing indicated in Minimum Requirement No. [5.] **5 as set forth in this Division.**

13.2.5 Minimum Requirement No. 5: Stabilize Soils.

1. General. All exposed and unworked soils shall be stabilized by application of effective BMPs that protect the soil from the erosive forces of raindrop impact and flowing water, and wind erosion. Establish temporary or permanent stabilization practices on areas that have been disturbed as soon as practical but no later than 14 days after disturbance.
2. Applicable Practices. Applicable practices include, but are not limited to, temporary and permanent seeding, sodding, mulching, plastic covering, soil application of polyacrylamide (PAM), early application of gravel base on areas to be paved, and dust control.
3. Soil Stabilization. Soil stabilization measures selected should be appropriate for the time of year, site conditions, estimated duration of use, and potential water quality impacts that stabilization agents may have on downstream waters or ground water.
4. Soil Stockpiles. Soil stockpiles must be stabilized and protected with sediment trapping measures. **Stockpiles may not be located for any period of time in any location designated by the Federal Emergency Management Agency as a Special Flood Hazard Area.**
5. Linear Facilities. Work on linear construction sites and activities, including right-of-way and easement clearing, roadway development, pipelines, and trenching for utilities, shall not exceed the capability of the individual contractor for his portion of the project to install the bedding materials, roadbeds, structures, pipelines, and/or utilities, and to re-stabilize the disturbed soils, meeting the timing conditions listed above.

13.2.6 Minimum Requirement No. 6: Protect Slopes.

1. Cut and Fill Slopes. Cut and fill slopes shall be designed and constructed in a manner that will minimize erosion. **If using coir logs or fiber roll as a temporary mechanism for slop stabilization, spacing intervals must not exceed 10 feet for 1:1 slopes, 20 feet for 2:1 slopes, 30 feet for 3:1 slopes and 40 feet for 4:1 slopes or flatter.**
2. Soil Types. Consider soil type and its potential for erosion.
3. Runoff Velocities. Reduce slope runoff velocities by breaking up the continuous length of slope with terracing and diversions, decreasing slope steepness, and roughening the slope surface.

4. Diverted Flows. Divert upslope drainage and run-on waters from off-site with interceptors at top of slope. Off-site stormwater should be handled separately from stormwater generated on the site. Diversion of off-site stormwater around the site may be a viable option. Diverted flows shall be redirected to the natural drainage location at or before the property boundary.
 5. Collected Flows. Contain down slope-collected flows in pipes, slope drains, or protected channels.
 6. Ground Water. Provide drainage improvements to intercept and remove ground water, preventing seepage from flowing onto the slope surface of exposed soil areas.
 7. Excavation. Excavated material shall be placed on the uphill side of trenches, consistent with safety and space considerations.
 8. Check Dams. Check dams shall be placed at regular intervals within trenches that are cut down a slope.
 9. Stabilize Soils. Stabilize soils on slopes, as specified in Minimum Requirement No. 5.
- 13.2.7 Minimum Requirement No. 7: Protect Drain Inlets.
1. General. All storm drain inlets made operable during construction shall be protected so that stormwater runoff shall not enter the conveyance system without first being filtered or treated to remove sediment.
 2. Roads. All approach roads shall be kept clean, and all sediment and street wash water shall not be allowed to enter storm drains without prior and adequate treatment unless treatment is provided before the storm drain discharges to waters of the State.
 3. Inlets should be inspected weekly at a minimum and daily during storm events. Inlet protection devices [~~should~~] **must** be cleaned or removed and replaced before [~~six~~] **6** inches of sediment can accumulate. **Inlet protection devices that show any sign of damage, including, without limitation, damage to gravel bags or flattening of coir logs or fiber rolls, must be replaced immediately.**
- 13.2.8 Minimum Requirement No. 8: Stabilize Channels and Outlets.
1. General. All temporary on-site conveyance channels shall be designed, constructed and stabilized to prevent erosion from the expected peak flows velocity of the 6 months, [~~3-hour~~] **3-hour** storm for the developed condition, referred to as the short duration storm.
 2. Stabilization. Stabilization, including armoring material, adequate to prevent erosion of outlets, adjacent stream banks, slopes and downstream reaches shall be provided at the outlets of all conveyance systems.
- 13.2.9 Minimum Requirement No. 9: Control Pollutants.

1. General. All pollutants, including waste materials and demolition debris, that occur on-site during construction shall be handled and disposed of in a manner that does not cause contamination of stormwater.
2. Vandalism. Cover, containment, and protection from vandalism shall be provided for all chemicals, liquid products, petroleum products, and non-inert wastes present on the site.
3. Equipment Maintenance. Maintenance and repair of heavy equipment and vehicles involving oil changes, hydraulic system drain down, solvent and degreasing cleaning operations, fuel tank drain down and removal, and other activities which may result in discharge or spillage of pollutants to the ground or into stormwater runoff must be conducted using spill prevention measures, such as drip pans. Contaminated surfaces shall be cleaned immediately following any discharge or spill incident. Emergency repairs may be performed on-site using temporary plastic placed beneath and, if raining, over the vehicle.
4. Wheel Wash. Wheel wash, or tire bath wastewater, shall be discharged to a separate on-site treatment system. It may be discharged to the sanitary sewer system only if expressly allowed by the ~~[city engineer.]~~ **City Engineer.**
5. Agricultural Chemicals. Application of agricultural chemicals, including fertilizers and pesticides, shall be conducted in a manner and at application rates that will not result in loss of chemical to stormwater runoff. Manufacturers' recommendations shall be followed for application rates and procedures.
6. pH Management. Management of pH-modifying sources shall prevent contamination of runoff and stormwater collected on the site. These sources include, but are not limited to, bulk cement, cement kiln dust, fly ash, new concrete washing and curing waters, waste streams generated from concrete grinding and sawing, exposed aggregate processes, and concrete pumping and mixer washout waters.

13.2.10 Minimum Requirement No. 10: Control De-Watering.

1. General. All foundation, vault, and trench de-watering water, which have similar characteristics to stormwater runoff at the site, shall be discharged into a controlled conveyance system, prior to discharge to a sediment trap or sediment pond. Channels must be stabilized, as specified in Minimum Requirement No. 8.
2. Clean Water. Clean, non-turbid de-watering water, such as well-point ground water, can be discharged to systems tributary to state surface waters, as specified in Minimum Requirement No. 8, provided the de-watering flow does not cause erosion or flooding of the receiving waters. These clean waters should not be routed through sediment ponds with stormwater.
3. Contaminated Water. Highly turbid or otherwise contaminated dewatering water, such as from construction equipment operation, clamshell digging, concrete tremie pour, or work inside a cofferdam, shall be handled separately from stormwater at the site.

4. Other Disposal Options. Depending on site constraints, additional methods of dewatering may include: infiltration; transport off-site in a vehicle, such as a vacuum flush truck, for legal disposal in a manner that does not pollute state waters; on-site treatment using chemical treatment; or other suitable treatment technologies.

13.2.11 Minimum Requirement No. 11: Maintain BMPs.

1. General. All temporary and permanent erosion and sediment control BMPs shall be maintained and repaired as needed to assure continued performance of their intended function. All maintenance and repair shall be conducted in accordance with BMPs.
2. Inspection. Sediment control BMPs shall be inspected by the permittee weekly or after a runoff-producing storm event. The inspection frequency for stabilized, inactive sites shall be determined by the Public Works Department, Development Engineering based on the level of soil stability and potential for adverse environmental impacts.
3. Remove BMPs. All temporary erosion and sediment control BMPs shall be removed within 30 days after final site stabilization is achieved or after the temporary BMPs are no longer needed. Trapped sediment shall be removed or stabilized on-site. Disturbed soil areas resulting from removal of BMPs or vegetation shall be permanently stabilized.

13.2.12 Minimum Requirement No. 12: Manage ~~[The]~~ **the** Project.

1. Phasing of Construction. Development projects shall be phased where feasible in order to prevent, to the maximum extent practicable, the transport of sediment from the project site during construction. Revegetation of exposed areas and maintenance of that vegetation shall be an integral part of the activities for any phase. Clearing and grading activities for developments shall be permitted only if conducted pursuant to an approved site development plan (e.g., subdivision approval) that establishes permitted areas of clearing, grading, cutting, and filling. When establishing these permitted clearing and grading areas, consideration should be given to minimizing removal of existing trees and minimizing disturbance/compaction of native soils except as needed for building purposes. These permitted clearing and grading areas and any other areas required to preserve critical or sensitive areas, buffers, native growth protection easements, or tree retention areas as may be required by the Director, shall be delineated on the site plans and the development site.
2. Coordination with Other Contractors. The permittee shall evaluate, with input from utilities and other contractors, the stormwater management requirements for the entire project, including the utilities, when preparing the Construction ~~[SWPPP.]~~ **SWPPP or Erosion Control Plan.**
3. Inspection. All BMPs shall be inspected, maintained, and repaired as needed to assure continued performance of their intended function. Permittees or their agents should conduct construction site inspections at least once every seven days and within 24 hours of a storm event of that creates runoff at the site. Inspections

should also occur prior to forecasted rain events to ensure that BMPs are in place and functioning properly. Inspections must be documented and the documents retained on site. Areas that require inspection include:

- a. Disturbed areas that have not attained final stabilization;
 - b. Material and equipment storage areas **and trash enclosures** that are exposed to precipitation;
 - c. All erosion and sediment control measures installed at the site and downstream of the site;
 - d. All structural control measures; and
 - e. All locations where vehicles enter and/or exit the site.
4. Modify SWPPP. Whenever inspection and/or monitoring reveals that the BMPs identified in the Construction SWPPP are inadequate, due to the actual discharge of or potential to discharge a significant amount of any pollutant, the SWPPP shall be modified, as appropriate, in a timely manner.
 5. Construction SWPPP. The Construction SWPPP shall be retained on-site or within reasonable access to the site. The Construction SWPPP shall be modified whenever there is a significant change in the design, construction, operation, or maintenance of any BMP.

SECTION XXXX:

That Title 18 Appendix (CARSON CITY DEVELOPMENT STANDARDS), Division 13 (EROSION & SEDIMENT CONTROL), Section 13.3 (Construction stormwater pollution prevention plan (SWPPP)) is hereby amended (**bold, underlined** text is added, [~~stricken~~] text is deleted) as follows:

13.3 Construction [~~stormwater pollution prevention plan~~] Erosion and Sediment Control Plan; Stormwater Pollution Prevention Plan (SWPPP).

There are three basic steps in producing an erosion and sediment control plan or Construction SWPPP. This section outlines and describes a recommended step-by-step procedure for developing a Construction SWPPP from data collection to finished product. This procedure is written in general terms to be applicable to all types of projects.

The Construction SWPPP is a document that describes the potential for pollution problems on a construction project. The Construction SWPPP also explains and illustrates the measures to be taken on the construction site to control those problems.

While it is a good idea to include standards and specifications from the Construction SWPPP in the contract documents, the Construction SWPPP should be a separate document that can stand-alone. The Construction SWPPP must be located on the construction site or within reasonable access to the site for construction and inspection personnel, although a copy of the drawings must be kept on the construction site at all times.

Division 13.4 includes a checklist for developing a Construction SWPPP. The Construction SWPPP may be a subset of the Technical Drainage Study, Improvement Plan or construction plan set. As site work progresses, the plan must be modified to reflect changing site conditions. The owner or lessee of the land being developed has the responsibility for Construction SWPPP preparation. The owner or lessee may designate someone (i.e., an engineer, architect, contractor, etc.) to prepare the Construction SWPPP, but he/she retains the ultimate responsibility.

13.3.1 What is an Adequate Plan?

The Construction SWPPP must contain sufficient information to satisfy the Public Works Department, Development Engineering that the problems of pollution have been adequately addressed for the proposed project. An adequate Construction SWPPP includes a narrative and drawings. The narrative is a written statement to explain and justify the pollution prevention decisions made for a particular project. The narrative contains concise information about existing site conditions, construction schedules, and other pertinent items that are not contained on the drawings. The drawings and notes describe where and when the various BMPs should be installed, the performance the BMPs are expected to achieve, and actions to be taken if the performance goals are not achieved.

On construction sites that discharge to surface water, the primary concern in the preparation of the Construction SWPPP is compliance with Nevada Water Quality Standards. Each of the 12 elements must be included in the Construction SWPPP unless an element is determined not to be applicable to the project and the exemption is justified in the narrative. The step-by-step procedure outlined in this section is recommended for the development of the Construction SWPPPs. The checklists presented in this section may be helpful in preparing and reviewing the Construction SWPPP.

On construction sites that infiltrate all stormwater runoff, the primary concern in the preparation of the Construction SWPPP is the protection of the infiltration facilities from fine sediments during the construction phase and protection of ground water from other pollutants. Several of the other elements are very important at these sites as well, such as marking the clearing limits, establishing the construction access, and managing the project.

13.3.2 BMP Standards and Specifications.

Division 13.5 contains references for standards and specifications for the BMPs referred to in this Division. Wherever any of these BMPs are to be employed on a site, the specific title and number of the BMP should be clearly referenced in the narrative and marked on the drawings. The standards and specifications in Division 13.5 of this Division are not intended to limit any innovative or creative effort to effectively control erosion and sedimentation. In those instances where appropriate BMPs are not in this Division, experimental management practices can be considered. Minor modifications to standard practices may also be employed. However, such practices must be approved by the ~~[city engineer]~~ **City Engineer** before they may be used. All experimental management practices and modified standard practices are required to achieve the same or better performance than the BMPs listed in Division 13.5.

13.3.3 General Principles.

The following general principals should be applied to the development of the Construction SWPPP:

- The native topsoil and natural vegetation should be retained in an undisturbed state to the maximum extent practicable.
- Prevent pollutant release. Select source control BMPs as a first line of defense. Prevent erosion rather than treat turbid runoff.
- Select BMPs depending on site characteristics (topography, drainage, soil type, ground cover, and critical areas) and the construction plan.
- Divert runoff away from exposed areas wherever possible. Keep clean water clean.
- Limit the extent of clearing operations and phase construction operations.
- Before reseeding a disturbed soil area, amend all soils with compost wherever topsoil has been removed.
- Incorporate natural drainage features whenever possible, using adequate buffers and protecting areas where flow enters the drainage system.
- Minimize slope length and steepness.
- Reduce runoff velocities to prevent channel erosion.
- Prevent the tracking of sediment off-site.
- Select appropriate BMPs for the control of pollutants other than sediment.
- Be realistic about the limitations of control that you specify and the operation and maintenance of those controls. Anticipate what can go wrong, how you can prevent it from happening, and what will need to be done to fix it.

13.3.4 Step-By-Step Procedure.

The development of the Construction SWPPP includes the following three steps:

Step 1 - Data Collection.

Step 2 - Data Analysis.

Step 3 - Construction SWPPP Development and Implementation.

a. Step 1 - Data Collection.

Evaluate existing site conditions and gather information that will help develop the most effective Construction SWPPP. The information gathered should be explained in the narrative and shown on the drawings.

Topography: Prepare a topographic drawing of the site to show the existing contour elevations at intervals of 1 to 5 feet depending upon the slope of the terrain.

Drainage: Locate and clearly mark existing drainage swales and patterns on the drawing, including existing storm [~~drainpipe~~] **drain** systems.

Soils: Identify and label soil type(s) and erodibility (low, medium, high or an index value from the NRCS manual) on the drawing. Soils information can be obtained from the "Soil Survey of Carson City Area, Nevada." Soils can be characterized for permeability, percent organic matter, and effective depth. These qualities can be expressed in averaged or nominal terms for most areas of Carson City. The information found in the Soil Survey lists the following information for each soil mapping unit or designation:

- A sieve analysis of the soils.
- Permeability (in/hr).
- Available water-holding capacity (in/in).
- The percent of organic matter.

Ground Cover: Label existing vegetation on the drawing. Such features as tree clusters, grassy areas, and unique or sensitive vegetation should be shown. Unique vegetation may include existing trees above a given diameter. In addition, existing denuded or exposed soil areas should be indicated.

Critical Areas: Delineate critical areas adjacent to or within the site on the drawing. [~~Such features~~] **Features such** as steep slopes, streams, floodplains, wetlands, and geologic hazard areas, etc., should be shown. Delineate set backs and buffer limits for these features on the drawings. Other related jurisdictional boundaries such as the Federal Emergency Management Agency (FEMA) base floodplain should also be shown on the drawings.

Adjacent Areas: Identify existing buildings, roads, and facilities adjacent to or within the project site on the drawings. Identify existing and proposed utility locations, construction clearing limits and erosion and sediment control BMPs on the drawings.

Existing Encumbrances: Identify wells, existing and abandoned septic drain-fields, utilities, and site constraints.

Precipitation Records: Determine the average monthly rainfall and rainfall intensity for the required design storm events based on information available in the NOAA atlas.

b. Step 2 - Data Analysis.

Consider the data collected in Step 1 to visualize potential problems and limitations of the site. Determine those areas that

have critical erosion hazards. The following are some important factors to consider in data analysis:

Topography: The primary topographic considerations are slope steepness and slope length. Because of the effect of runoff, the longer and steeper the slope, the greater the erosion potential. Erosion potential should be determined by a qualified engineer, soil professional, certified erosion control specialist, or other qualified person.

Drainage: Natural drainage patterns that consist of overland flow, swales and depressions should be used to convey runoff through the site to avoid constructing an artificial drainage system. Man-made ditches and waterways will become part of the erosion problem if they are not properly stabilized. Care should also be taken to ensure that increased runoff from the site will not erode or flood the existing natural drainage system. Possible sites for temporary stormwater retention and detention should be considered ~~[at this point]~~. Direct construction away from areas of saturated soil—areas where ground water may be encountered—and critical areas where drainage will concentrate. Preserve natural drainage patterns on the site.

Soils: Evaluate soil properties such as surface and subsurface runoff characteristics, depth to impermeable layer, depth to seasonal ground water table, permeability, shrink-swell potential, texture, settleability, and erodibility. Develop the Construction SWPPP based on known soil characteristics. Infiltration sites should be properly protected from silt, which will reduce infiltration capacities.

Ground Cover: Ground cover is the most important factor in terms of preventing erosion. Existing vegetation that can be saved will prevent erosion better than constructed BMPs. Trees and other vegetation protect the soil structure. If the existing vegetation cannot be saved, consider such practices as phasing construction, temporary seeding, and mulching. Phasing of construction involves stabilizing one part of the site before disturbing another. In this way, the entire site is not disturbed at once.

Critical Areas: Critical areas may include flood hazard areas, mine hazard areas, slide hazard areas, sole source aquifers, wetlands, stream banks, fish-bearing streams, and other water bodies. Any critical areas within or adjacent to the development should exert a strong influence on land development decisions. Critical areas and their buffers shall be delineated on the drawings and clearly flagged in the field. Chain link fencing may be more useful than flagging to assure that equipment operators stay out of critical areas. Only unavoidable work should take place within

critical areas and their buffers. Such unavoidable work will require special BMPs, permit restrictions, and mitigation plans.

Adjacent Areas: An analysis of adjacent properties should focus on areas upslope and down slope from the construction project. Water bodies that will receive direct runoff from the site are a major concern. The types, values, and sensitivities of and risks to downstream resources, such as private property, stormwater facilities, public infrastructure, or aquatic systems, should be evaluated. Erosion and sediment controls should be selected accordingly.

Timing of the Project: An important consideration in selecting BMPs is the timing and duration of the project. Projects that will last through several seasons must take all necessary precautions to remain in compliance with the water quality standards.

c. Step 3 - Construction SWPPP Development and Implementation.

After collecting and analyzing the data to determine the site limitations, the planner can then develop a Construction SWPPP. Each of the 12 minimum requirements must be considered and included in the Construction SWPPP unless site conditions render the minimum requirement unnecessary and the exemption from that element is clearly justified in the narrative of the SWPPP. The 12 minimum requirements are discussed in Division 13.2. A list of recommended BMPs for these minimum requirements is provided below.

13.3.5 Suggested BMPs for 12 Minimum Requirements.

a. Suggested BMPs for Minimum Requirement No. 1: Mark Clearing Limits.

BMP EC-2: Preserving Natural Vegetation

BMP EC-3: Buffer Zones

BMP EC-4: High Visibility Plastic or Metal Fence

b. Suggested BMPs for Minimum Requirement No. 2: Establish Construction Access.

BMP SC-1: Stabilized Construction Entrance

BMP SC-2: Wheel Wash

BMP EC-6: Construction Road/Parking Area Stabilization

c. Suggested BMPs for Minimum Requirement No. 3: Control Flow Rates.

BMP SC-4: Storm Drain Inlet Protection

BMP SC-5: Sandbag Curb Inlet Sediment Barrier

BMP SC-6: Filter Strips

BMP SC-14: Sediment Trap

- BMP SC-15: Temporary Sediment Pond
- d. Suggested BMPs for Minimum Requirement No. 4: Install Sediment Controls.
 - BMP SC-3: Straw Bale Barriers
 - BMP SC-6: Filter Strips
 - BMP SC-7: Silt Fence
 - BMP SC-8: Gravel Filter Berms
 - BMP SC-11: Brush Barrier
 - BMP SC-13: Straw Wattles
 - BMP SC-14: Sediment Trap
 - BMP SC-15: Temporary Sediment Pond
 - BMP SC-16: Construction Stormwater Filtration
- e. Suggested BMPs for Minimum Requirement No. 5: Stabilize Soils.
 - BMP EC-7: Dust Control
 - BMP EC-15: Wood Chip, Straw and Bark Mulches
 - BMP EC-16: Plastic Covering
 - BMP EC-17: Jute and Synthetic Netting
 - BMP EC-21: Seeding Practices
 - BMP EC-19: Polyacrylamide for Soil Erosion Protection
 - BMP EC-20: Topsoiling
 - BMP EC-22: Sodding
- f. Suggested BMPs for Minimum Requirement No. 6: Protect Slopes.
 - BMP EC-8: Level Spreader
 - BMP EC-9: Subsurface Drains
 - BMP EC-10: Pipe Slope Drains
 - BMP EC-12: Grassed Waterways and Outlets
 - BMP EC-14: Check Dams
 - BMP EC-21: Seeding Practices
 - BMP SC-10: Interceptor Dike and Swale
- g. Suggested BMPs for Minimum Requirement No. 7: Protect Drain Inlets.
 - BMP SC-4: Storm Drain Inlet Protection
 - BMP SC-5: Sandbag Curb Inlet Sediment Barrier
- h. Suggested BMPs for Minimum Requirement No. 8: Stabilize Channels and Outlets.

BMP EC-11: Channel Lining

BMP EC-13: Outlet Protection

- i. Suggested BMPs for Minimum Requirement No. 9: Control Pollutants.

BMP MC-1: Saw cutting and Surface Pollution Prevention

BMP MC-2: Concrete Handling

- j. Suggested BMPs for Minimum Requirement No. 10: Control De-Watering.

BMP SC-3: Straw Bale Barrier

BMP SC-6: Filter Strips

BMP SC-8: Gravel Filter Berms

BMP SC-13: Straw Wattles

BMP SC-14: Sediment Trap

BMP SC-15: Temporary Sediment Pond

BMP SC-16: Construction Stormwater Filtration

- k. Suggested BMPs for Minimum Requirement No. 11: Maintain BMPs.

Sediment control BMPs shall be inspected by project personnel every day when there is a discharge from the site (stormwater or non-stormwater), and at least weekly when there is no discharge.

Repair or replace BMP as necessary to ensure that BMP is performing as intended.

Remove BMPs within 30 days after final site stabilization is achieved or when they are no longer needed.

- l. Suggested BMPs for Minimum Requirement No. 12: Manage the Project.

Inspection and Monitoring of BMPs

Phasing of Construction

Prepare and follow Construction SWPPP

BMP EC-1: Grading Season and Practices

BMP MC-1: Concrete Handling

BMP MC - 2: Saw cutting and Surface Pollution Prevention

BMP MC-3: Materials Management

SECTION XXXX:

That Title 18 Appendix (CARSON CITY DEVELOPMENT STANDARDS), Division 13 (EROSION & SEDIMENT CONTROL), Section 13.4 (Checklists for

construction stormwater pollution prevention plans SWPPPs) is hereby amended (**bold, underlined** text is added, [~~stricken~~] text is deleted) as follows:

13.4 Checklists for construction stormwater pollution prevention plans [~~SWPPPs.~~] (SWPPPs)

The Construction SWPPP consists of two parts: a narrative and the drawings. The following two sections describe the contents of the narrative and the drawings. A checklist is included that can be used as a quick reference to determine if all the major items are included in the Construction SWPPP.

13.4.1 Narrative.

12 Minimum Requirements - Describe how the Construction SWPPP addresses each of the twelve minimum requirements. Include the type and location of BMPs used to satisfy the required element. If an element is not applicable to a project, provide a written justification for why it is not necessary.

Project description - Describe the nature and purpose of the construction project. Include the size of the project area, any increase in existing impervious area, the area disturbed, and the volumes of grading cut and fill that are proposed.

Existing site conditions - Describe the existing topography, vegetation, and drainage. Include a description of any structures or development on the parcel including the area of existing impervious surfaces.

Adjacent areas - Describe adjacent areas, including streams, wetlands, residential areas, and roads that might be affected by the construction project. Provide a description of the downstream drainage leading from the site to the receiving body of water. Also define the tributary upstream drainage area that may discharge runoff to the site.

Critical areas - Describe areas on or adjacent to the site that are classified as critical areas. Critical areas that receive runoff from the site shall be described up to ¼ mile away. The distance may be increased by the [~~city engineer.~~] **City Engineer.** Describe special requirements for working near or within these areas.

Soil - Describe the soil on the site, giving such information as soil names, mapping unit, erodibility, settleability, permeability, depth, texture, and soil structure.

Potential erosion problem areas - Describe areas on the site that have potential erosion problems.

Construction phasing - Describe the construction sequence and any proposed construction phasing.

Construction schedule - Describe the construction schedule. If the schedule extends into the wet season, describe what activities will continue during the wet season and how the transport of sediment from the construction site to receiving waters will be prevented.

Financial/ownership responsibilities - Describe ownership and obligations for the project. Include bond forms and other evidence of financial responsibility for environmental liabilities associated with construction.

Engineering calculations - Attach any calculations made for the design of such items as sediment ponds, diversions, and waterways, as well as calculations for runoff and stormwater detention design (if applicable). Engineering calculations must bear the signature and stamp of an engineer licensed in the state of Nevada.

Responsibility - The party responsible for the erosion control installation and maintenance shall be identified. Telephone [~~and/or pager~~] numbers, **email addresses and any other relevant contact information** should be included.

13.4.2 Drawings.

- a. Vicinity map - Provide a map locating the site in relation to the surrounding area and roads.
- b. Site map - Provide a site map(s) showing the following features. The site map requirements may be met using multiple plan sheets for ease of legibility.
 1. A legal description of the property boundaries or an illustration of property lines (including distances) in the drawings.
 2. The direction of north in relation to the site.
 3. Existing **storm drain infrastructure**, structures and roads, if present.
 4. The descriptions and boundaries of the different soil types.
 5. Areas of potential erosion problems.
 6. Any on-site and adjacent critical areas, their buffers, FEMA base flood boundaries.
 7. Existing contours and drainage basins and the direction of flow for the different drainage areas.
 8. Final grade contours and developed condition drainage basins.
 9. Areas that are to be cleared and graded.
 10. Existing unique or valuable vegetation and the vegetation that is to be preserved.
 11. Cut and fill slopes indicating top and bottom of slope catch lines.
 12. Stockpile, waste storage, and vehicle storage/maintenance areas.
 13. Estimated cut and fill quantities and the method of disposal for excess material.
- c. Conveyance systems - Show on the site map the following temporary and permanent conveyance features:
 1. Locations for swales, interceptor trenches, or ditches.

2. Drainage pipes, ditches, or cut-off trenches associated with erosion and sediment control and stormwater management.
 3. Temporary and permanent pipe inverts and minimum slopes and cover.
 4. Grades, dimensions, and direction of flow in all ditches, channels, swales, culverts, and pipe systems.
 5. Details for perpetuating off-site runoff through the site, around disturbed areas.
 6. Locations and outlets of any dewatering systems.
- d. Detention Systems - Location of detention BMPs - Show on the site map the locations of stormwater detention BMPs.
 - e. Erosion and Sediment Control (ESC) Facilities - Show on the site map the following ESC facilities:
 1. The location of sediment traps/ponds, pipes and structures.
 2. Dimension trap/pond berm widths and inside and outside slopes.
 3. The trap/pond storage required and the depth, length, and width dimensions.
 4. Typical section views through trap/pond and outlet structure.
 5. Typical details of gravel cone and standpipe, and/or other filtering devices.
 6. Stabilization technique details for inlets and outlets.
 7. Control/restrictor device location and details.
 8. Mulch and/or recommended cover of berms and slopes.
 9. Rock specifications and detail for rock check dam, if used.
 10. Spacing for rock check dams as required.
 11. Front and side sections of typical rock check dams.
 12. The location, detail, and specification for silt fence or other perimeter protection.
 13. The construction entrance location and [a] detail.
 - f. Detailed drawings - Any structural practices used that are not referenced in this manual or other local manuals should be explained and illustrated with detailed drawings.
 - g. Other pollutant BMPs - Indicate on the site map the location of BMPs to be used for the control of pollutants other than sediment.
 - h. Construction Notes - Notes addressing construction phasing and scheduling shall be included on the drawings.

13.4.3 Recommended standard notes for erosion and sediment control plans.

The name, telephone number, email address and any other relevant contact information of the person or entity who prepares an erosion and sediment control plan should be identified in the plan.

The approval of an erosion and sediment control plan does not constitute the approval of any permanent road or drainage design, including, without limitation, the size and location of roads, pipes, restrictors, channels, retention facilities and utilities.

The implementation of any erosion and sediment control plan and the construction, maintenance, replacement and upgrading of a plan facility is the responsibility of the applicant until all construction is completed and approved and required vegetation and landscaping has been completed.

The boundaries of the clearing limits as shown on an erosion and sediment control plan must be conspicuously flagged in the field before construction may commence. Any disturbance beyond the flagged clearing limits during the period of construction is prohibited. The flagging must be maintained by the applicant throughout the duration of construction.

Facilities shown on an erosion and sediment control plan must be constructed in conjunction with all clearing and grading activities and in a manner that ensures sediment and sediment laden water do not enter the drainage system or roadways or otherwise violate water quality standards.

The facilities to be shown on an erosion and sediment control plan are the minimum requirements for anticipated site conditions. These facilities must be upgraded as necessary during the construction period for unexpected storm events and to ensure that sediment and sediment laden water do not leave the site.

The plan facilities on an active site must be inspected daily by the applicant and maintained as necessary to ensure continuous functionality.

The plan facilities on an inactive site must be inspected and maintained not less than once a month or, if a major storm event has occurred, not longer than 48 hours immediately following the storm event.

Not more than 1 foot of sediment may be allowed to accumulate within a trapped basin at any time. All catch basins and conveyance lines must be cleaned before paving. Any cleaning must not flush sediment or sediment laden water into the downstream system.

Stabilized construction entrances must be installed at the time construction commences and maintained for the duration of the project. The City may require additional measures to ensure that all paved areas are kept clean for the duration of the project.

SECTION XXXX:

That Title 18 Appendix (CARSON CITY DEVELOPMENT STANDARDS), Division 13 (EROSION & SEDIMENT CONTROL), Section 13.5 (Best management practices) is hereby amended (**bold, underlined** text is added, [~~stricken~~] text is deleted) as follows:

13.5 Best management practices.

The following BMPs can be used on construction sites to reduce or prevent [~~erosion, reduce or prevent~~] **erosion and** the release of sediments to off-site areas and to [~~prevention~~] **prevent** storm water pollution. The BMPs are grouped according to the main categories of:

Erosion Control BMPs

Sediment Control BMPs

Management Source Control BMPs

The purpose of this compilation of BMPs is to provide general guidance for selecting and implementing BMPs that will eliminate or reduce the discharge of pollutants from construction sites. Many state, federal and local agencies and non-governmental groups have developed construction site BMPs handbooks. A list of the BMPs guidance and handbooks that were reviewed for this manual are listed below. The BMPs presented here include some of the [~~most commonly used~~] **more common** construction BMPs.

- California Stormwater BMP Handbook, Construction, California Stormwater Quality Association, 2003
- Construction Best Management Practices, Drainage Criteria Manual, Volume 3, Urban Drainage and Flood Control District, 1999
- Handbook of Best Management Practices, Nevada Division of Environmental Protection and Nevada Division of Conservation Districts, 1994
- Regional Road Maintenance Endangered Species Act, Program Guidelines, Regional Road Maintenance Technical Working Group, 2003
- Stormwater BMP Menu, U.S. Environmental Protection Agency
- Stormwater Management Design Manual, City of Boise
- Stormwater Management for Eastern Washington, Chapter 7, Construction Stormwater Pollution Prevention, Washington Department of Ecology, 2003
- Stormwater Management Manual for Western Washington, Washington Department of Ecology, 2001
- Surface Water Design Manual, King County, Washington Surface Water Management Division, 1998
- Truckee Meadows Construction Site Best Management Practices Handbook, Truckee Meadows Regional Stormwater Quality Management Program, 2003

13.5.1 BMP Selection.

Excessive erosion and sedimentation are among the most visible water quality impacts due to construction activities. Other water quality impacts caused by construction activities include the discharge of gross pollutants such as metals, paint, **concrete washout**, nutrients, plant debris, pesticides, construction chemicals, trash, debris and floatables into storm water. Table 1 presents a matrix that identifies the most common source of storm water pollutants at construction sites.

**Table 1
Construction Activity Pollutants**

Construction Activity	Pollutants						
	Sediment	Nutrients	Trace Metals	Pesticides	Oil, Grease, Fuels	Other Toxic Chemicals	Miscellaneous Waste
Construction Practices							
Clearing and Grading Operations	X					X	
Dewatering Operations	X						
Paving Operations	X			X	X	X	X
Structure Construction/Painting			X			X	X
Material Management							
Material Delivery and Storage	X	X	X	X	X	X	
Material Use		X	X	X	X	X	
Waste Management							
Solid Waste	X	X					X
Hazardous Waste						X	
Contaminated Spills	X					X	
Concrete Waste							X
Sanitary/Septic Waste							X
Vehicle/Equipment Management							
Vehicle/Equipment Fueling						X	X
Vehicle/Equipment Maintenance						X	X

Based on: California Stormwater BMP Handbook, Construction, 2003

BMPs for erosion and sediment control must be selected to meet the BMP objectives based on site-specific conditions, construction activities, and cost. The goal of construction BMPs is to minimize the disturbed areas, stabilize disturbed areas and protect slopes and channels from erosion. Several considerations for selecting BMPs for contractor activities include:

Is it expected to rain? Selection of a BMP is different for the rainy season versus the dry season. Consider rescheduling activities until after the rains or perform in dry season.

How much water is being used for construction activities? The more water used the more likely that pollutants transported by this water will reach the drainage system or be transported off-site.

What are the site conditions? BMPs may differ depending on whether the activity is conducted on a slope or flat ground near a drainage structure or watercourse. Conducting activities away from certain sensitive areas will reduce the cost and inconvenience of implementing BMPs.

What about accidents? Controls for common activities should be established, and preparations should be made to allow for quick response to accidents or spills. In the event of a spill or exposure of construction compounds, what are the contingency plans for sampling the contaminated stormwater? Can the analysis be done in the field or should laboratory analysis be required? Are sample bottles available on-site, appropriated test strips, etc?

13.5.2 BMP Monitoring.

All construction site BMPs must be monitored on a regular basis to ensure that ~~[the BMP is]~~ **they are** functioning as designed. The monitoring consists of visual inspection to determine whether the BMP was implemented and maintained ~~[according to]~~ **in accordance with the erosion and sediment control plan or** the SWPPP. Site inspections can include:

- a. Contractor activity BMPs.
 - Looking for evidence of spills and resulting clean-up procedures (e.g., supplies of spill cleanup materials)
 - Verifying adequacy of trash receptacles **and concrete washouts**
 - Verifying waste disposal practices ~~[(e.g., recycle vs.)]~~ **, including recycling and the use of** hazardous waste ~~[bins]~~ **bins.**
 - Examining integrity and use of containment structures
 - Verifying use of ~~[employees]~~ **employee** education programs for the various activities
 - Noting the location of activity (e.g., outdoor vs. indoor, concrete vs. grass)
 - BMPs for any chemicals or fuels not addressed in the SWPPP must be developed
- b. Erosion and sediment control BMPs.
 - Are erosion and sediment control BMPs installed properly? The **erosion ad sediment control plan or** SWPPP BMPs should include details or references to allow for the proper construction of structural or vegetative erosion and sediment control devices. The inspector should ensure that these systems are installed according to the ~~[SWPPP]~~ **plan** in the proper locations
 - Are the BMPs effective? The effectiveness of the BMP would be based on the presence of sediment behind or within control devices, the presence of sediment downstream of the site, and signs of erosion in stabilized areas after a storm event
 - Have drainage patterns changed? If the site has undergone significant grading operations, resulting in a change of drainage patterns, adjustment to the BMPs will likely be required to address this change. The inspectors shall determine the extent of changes to the drainage pattern and the necessity for additional or reconfigured BMPs
 - Are areas stabilized as quickly as possible after completion of construction activities in an area? Disturbed active and inactive construction areas (inactive construction areas may be defined as areas in which no construction activity will occur for a period of 30 days or longer) should be stabilized as soon as practical. If construction,

climatological, or other site conditions do not allow stabilization, the SWPPP should define alternative approaches

- Are the BMPs properly maintained? Maintenance of erosion and sediment control BMPs is critical. Erosion controls should be installed as soon as practical after an area becomes inactive, and before the onset of rain. The capacity of sediment controls must be restored prior to the next rain event

13.5.3 BMP Maintenance.

The construction site should be inspected [~~on a regular basis~~] **weekly** and during and after any storm generating runoff to determine maintenance requirements and general condition of the installed system. All maintenance related to a storm event should be completed within 48 hours of the storm event. The following maintenance tasks should be performed [~~on a regular basis~~] **weekly**:

- Removal of sediment from barriers and sedimentation devices
- Replacement or repair of worn or damaged silt fence fabrics
- Replacement or repair of damaged structural controls
- Repair of damaged soil stabilization measures
- Other control maintenance as [~~defined in each BMP fact sheet~~] **required for erosion and sediment control plan BMPs as described in subsection 13.5.4.**

13.5.4 Erosion and Sediment Control BMPs.

Table 2 lists the BMPs contained in this Division that are primarily installed to prevent or minimize erosion on the construction site by protecting the soil surface and preventing soil particles from being detached by rainfall, flowing water or wind. In addition, several of the erosion control BMPs are appropriately used to prevent erosion due to concentrated flow on off-site areas.

**Table 2
Erosion Control BMPs**

EC-1	Grading Season and Practices
EC-2	Preserving Natural Vegetation
EC-3	Buffer Zones
EC-4	High Visibility Plastic or Metal Fence
EC-5	Access Roads
EC-6	Construction Road/Parking Area Stabilization
EC-7	Dust and Wind Erosion Control
EC-8	Level Spreader
EC-9	Subsurface Drains
EC-10	Pipe Slope Drains
EC-11	Channel Lining
EC-12	Grassed Waterways and Outlets
EC-13	Outlet Protection
EC-14	Check Dams
EC-15	Wood Chip, Straw and Bark Mulches

EC-16	Plastic Covering
EC-17	Jute & Synthetic Netting and Blankets
EC-18	Rock Riprap
EC-19	Polyacrylamide (PAM) for Soil Erosion Protection
EC-20	Topsoiling
EC-21	Seeding Practices
EC-22	Sodding

Table 3 lists the sediment control BMPs contained in this Division. Sediment control BMPs are implemented to trap soil particles after they have been detached and moved by rain, flowing water or wind.

**Table 3
Sediment Control BMPs**

SC-1	Stabilized Construction Entrance
SC-2	Wheel Wash
SC-3	Straw Bale Barrier
SC-4	Storm Drain Inlet Protection
SC-5	Sandbag Curb Inlet Sediment Barrier
SC-6	Filter Strips
SC-7	Silt Fence
SC-8	Gravel Filter Berm
SC-9	Gravel Bag Berm
SC-10	Interceptor Dike and Swale
SC-11	Brush Barrier
SC-12	Willow Wattles
SC-13	Straw Wattles
SC-14	Sediment Trap
SC-15	Temporary Sediment Pond
SC-16	Construction Stormwater Filtration

Table 4 lists the management source control BMPs contained in this [manual.] **Division**. Management source control BMPs are implemented to prevent potential pollution generating materials from coming in contact with stormwater.

**Table 4
Management Source Control BMPs**

MC-1	Concrete Handling
MC-2	Sawcutting & Surfacing Pollution Prevention
MC-3	Materials Management

A. Erosion Control BMPs.

1. BMP EC-1 grading season and practices.

Definition. The grading season is determined by the local climate conditions. All grading, clearing, and excavation work should be conducted during this period in order to avoid climatic conditions that could increase the chances for erosion.

Purpose. To coordinate grading and construction activities such that bare and disturbed soil exposure is minimized during [the winter snow, windy and rainy seasons.] **inclement weather.**

Applicability. For construction or development projects in locations where there is an opportunity for snow or rain to occur to the extent that soils become saturated and surface soil erosion is possible.

Planning Criteria. Many counties and communities have established specific grading and construction seasons applicable to their local environment. Coordination with the local building department or public works department will clarify any regulatory requirements applicable to the development project.

Methods and Materials. The best time to begin construction is after the snow has melted. All grading and excavation work should be completed prior to setting in of winter. At that time, all building sites should be winterized. Grading should not take place during storm events, rain, or snow, and for the following period of time when the site is covered with snow or the soil is in a wet saturated, muddy, or unstable condition.

2. BMP EC-2: Preserving Natural Vegetation.

Purpose. The purpose of preserving natural vegetation is to reduce erosion wherever practicable. Limiting site disturbance is the single most effective method for reducing erosion. Carefully planned preservation of existing trees, vines, shrubs, and grasses can protect soil from erosion.

Conditions of Use.

- Preservation of existing vegetation is suitable for use on most projects
- Natural vegetation should be preserved on steep slopes, near perennial and intermittent watercourses or swales, and on building sites in wooded areas
- Areas where Carson City or state regulations require preservation, e.g., wetland buffers, environmentally sensitive areas

Design and Installation Specifications. Natural vegetation can be preserved in natural clumps or as individual trees, shrubs and vines. The preservation of individual plants is more difficult because heavy equipment is generally used to remove unwanted vegetation. The points to remember when attempting to save individual plants are:

- Is the plant worth saving? Consider the location, species, size, age, vigor, and the work involved. Local governments may also have ordinances to save natural vegetation and trees
- Fence or clearly mark areas around trees that are to be saved. It is preferable to keep ground disturbance away from the trees at least as far out as the drip line.

Plants need protection from three kinds of injuries:

- **Construction Equipment** - This injury can be above or below the ground level. Damage results from scarring, cutting of roots, and compaction of the soil. Placing a fenced buffer zone around plants to be saved prior to construction can prevent construction equipment injuries
- **Grade Changes** - Changing the natural ground level will alter grades, which affects the plant's ability to obtain the necessary air, water, and minerals.

Minor fills usually do not cause problems although sensitivity between species does vary and should be checked. Trees can tolerate fill of 6 inches or less. For shrubs and other plants, the fill should be less. When there are major changes in grade, it may become necessary to supply air to the roots of plants. This can be done by placing a layer of gravel and a tile system over the roots before the fill is made. A tile system protects a tree from a raised grade. The tile system should be laid out on the original grade leading from a dry well around the tree trunk. The system should then be covered with small stones to allow air to circulate over the root area. Lowering the natural ground level can seriously damage trees and shrubs. The highest percentage of the plant roots are in the upper 12 inches of the soil and cuts of only 2-3 inches can cause serious injury. To protect the roots it may be necessary to terrace the immediate area around the plants to be saved. If roots are exposed, construction of retaining walls may be needed to keep the soil in place. Plants can also be preserved by leaving them on an undisturbed, gently sloping mound. To increase the chances for survival, it is best to limit grade changes and other soil disturbances to areas outside the drip line of the plant

- Excavations - Protect trees and other plants when excavating for drain fields, power, water, and sewer lines. Where possible, the trenches should be routed around trees and large shrubs. When this is not possible, it is best to tunnel under them. This can be done with hand tools or with power augers. If it is not possible to route the trench around plants to be saved, then the following should be observed:
 - ✓ Cut as few roots as possible. When you [~~have to~~] **must** cut, cut clean
 - ✓ Paint cut root ends with a wood dressing like asphalt base paint
 - ✓ Backfill the trench as soon as possible
 - ✓ Tunnel beneath root systems as close to the center of the main trunk to preserve most of the important feeder roots

Maintenance Standards. During construction, the limits of disturbance should remain clearly marked at all times. Irrigation or maintenance of existing vegetation should be described in the landscaping plan. If damage to protected trees still occurs, maintenance guidelines described below should be followed.

- Verify that protective [~~measure~~] **measures** remain in place. Restore damaged protection measures immediately
- Serious tree injuries shall be attended to by an arborist
- Damage to the crown, trunk, or root system of a retained tree shall be repaired immediately
- If bark damage occurs, cut back all loosened bark into the undamaged area, with the cut tapered at the top and bottom and drainage provided at the base of the wood. Limit cutting the undamaged area as much as possible

- Serrate soil that has been compacted over a tree's root zone by punching holes 12 inches deep with an iron [~~bar,~~] **bar** and moving the bar back and forth until the soil is loosened. Place holes 18 inches apart throughout the area of compacted soil under the tree crown
- Retain protective measures until all other construction activity is complete to avoid damage during site cleanup and stabilization

3. BMP EC-3: Buffer Zones.

Purpose. An undisturbed area or strip of natural vegetation or an established suitable planting that will provide a living filter to reduce soil erosion and runoff velocities.

Conditions of Use. Natural buffer zones are used along streams, wetlands and other bodies of water that need protection from erosion and sedimentation. Vegetative buffer zones can be used to protect natural swales and can be incorporated into the natural landscaping of an area. Critical-areas buffer zones should not be used as sediment treatment areas. These areas shall remain completely undisturbed.

Design and Installation Specifications. Preserving natural vegetation or plantings in clumps, blocks, or strips is generally the easiest and most successful method.

- Leave all unstable steep slopes in natural vegetation
- Mark clearing limits and keep all equipment and construction debris out of the natural areas. Steel construction fencing is the most effective method in protecting sensitive areas and buffers
- Alternatively, wire-backed silt fence on steel posts is marginally effective. Flagging alone is typically not effective
- Keep all excavations outside the drip line of trees and shrubs
- Do not push debris or extra soil into the buffer zone area because it will cause damage from burying and smothering
- Vegetative buffer zones for streams or other waterways shall be established by the local permitting authority or other state or federal permits or approvals

Maintenance Standards.

- Inspect the area frequently to make sure flagging remains in place and the area remains undisturbed

4. BMP EC-4: High Visibility Plastic or Metal Fence.

Purpose. Fencing is intended to: (1) restrict clearing to approved limits; (2) prevent disturbance of sensitive areas, their buffers, and other areas required to be left undisturbed; (3) limit construction traffic to designated construction entrances or roads; and, (4) protect areas where marking with survey tape may not provide adequate protection.

Conditions of Use. To establish clearing limits, plastic or metal fence may be used:

- At the boundary of sensitive areas, their buffers, and other areas required to be left uncleared
- As necessary to control vehicle access to and on the site

Design and Installation Specifications.

- High visibility plastic fence shall be composed of a high-density polyethylene material and shall be at least four feet in height. Posts for the fencing shall be steel or wood and placed every 6 feet on center (maximum) or as needed to ensure rigidity. The fencing shall be fastened to the post every six inches with a polyethylene tie. On long continuous lengths of fencing, a tension wire or rope shall be used as a top stringer to prevent sagging between posts. The fence color shall be high visibility orange. The fence tensile strength shall be 360 lbs./ft. using the ASTM D4595 testing method
- Metal fences shall be designed and installed according to the manufacturer's specifications
- Metal fences shall be at least 3 feet high and must be highly visible
- Fences shall not be wired or stapled to trees

Maintenance Standards.

- If the fence has been damaged or visibility reduced, it shall be repaired or replaced immediately and visibility restored

5. BMP EC-5: Access Roads.

Definition. Roads to provide needed access to an area should be constructed in such a way that the quality of runoff water is preserved.

Purpose. To provide a route for vehicle travel, for moving equipment, supplies, and products, and for providing access for proper operation and management of conservation enterprises without disturbing the quality of runoff water.

Applicability. Where roads are needed to provide access from a county, state, or federal highway or to provide planned travel-ways within an area.

Planning Criteria.

1. Location: Roads should be located to serve the purpose intended and to facilitate the control and disposal of surface water.
2. Gradient, Vertical, and Horizontal Alignment: The gradient and alignment should be adapted to the development of which it is a part.
3. Width: The recommended minimum width of the road-bed is [~~14~~] **12** feet for one-way traffic and 20 feet for two-way traffic. The tread width for two-way traffic should be increased approximately 5-feet for trailer traffic. The recommended minimum shoulder width is 2-feet on each side of the tread width. Widths less than recommended minimums may be used where topography or other natural conditions restrict the width.

4. Side Slopes: All cuts and fills should have side slopes that are stable for the soil or soil material involved. Typically side slopes should not be steeper than 2:1 (50% slope).
5. Drainage: Culverts, bridges, or grade dips should be provided at all natural drainage-ways. Design of these structures should be conducted by a qualified engineer in keeping with sound engineering practices for the class of vehicle or equipment used on the road.

Roadside ditches should be adequate to provide surface drainage for the roadway and deep enough to serve as outlets for subsurface drainage.

6. Erosion Control Measures: Erosion control measures should be provided for roads, ditches, cut slopes, fill slopes, and cross drains.
7. Surfacing: Access roads should be given a wearing course or surface treatment when required for traffic needs, climate, erosion control, or dust control. The type of treatment will depend on local conditions, available materials, and the existing road base. Where these factors and the volume of traffic are not a problem, no special treatment of the surface is required. Sound engineering practices must be followed to ensure that the road will meet the requirements of its intended use.
8. Intersection with Public Highways: Traffic safety should be a prime factor in selecting the angle of intersection with public highways. Any access roads that connect to a state highway must be approved by the State Highway Department.

Maintenance. Roadways, drainage structures, and erosion control facilities must be maintained on an as needed basis given the site specifics of the access road to keep them operational. Proper and regular maintenance will minimize soil erosion and the degradation of surface and ground water resources.

Effectiveness. Proper installation and maintenance of access roads can be effective in reducing soil erosion and minimizing impacts to water quality.

TYPICAL TURNOUT PLAN

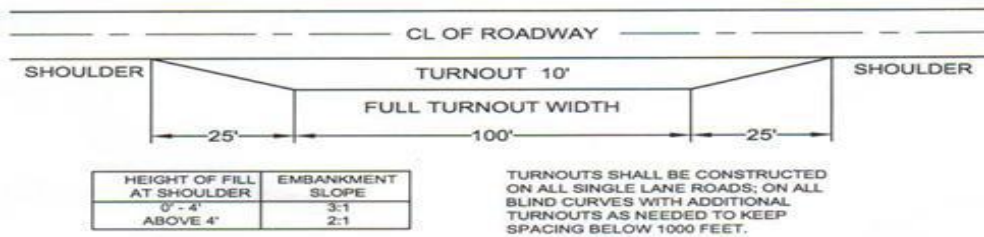

EMBANKMENT SECTION



SIDE HILL SECTION

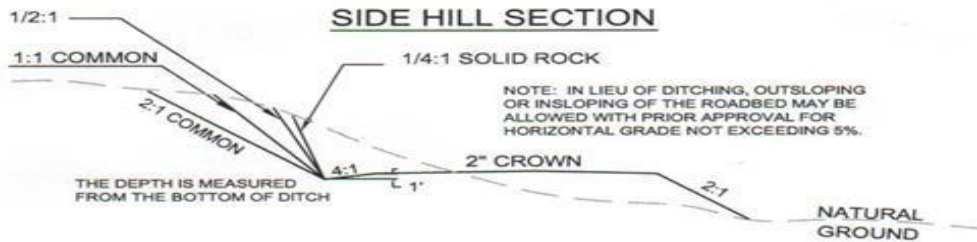

CUT SLOPE ROUNDING

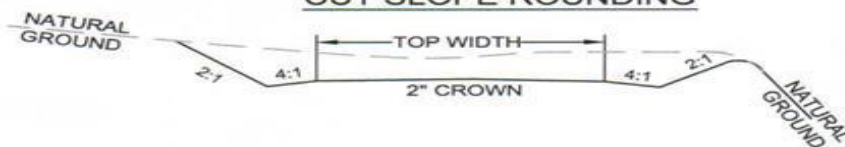

FLAT BOTTOM DITCH



6. BMP EC-6: Construction Road/Parking Area Stabilization.

Purpose. Stabilizing subdivision roads, parking areas, and other onsite vehicle transportation routes immediately after grading reduces erosion caused by construction traffic or runoff.

Conditions of Use.

- Roads or parking areas, whether permanent or temporary, shall be stabilized wherever they are constructed, for use by construction traffic
- Fencing (see BMPs EC-4) shall be installed, if necessary, to limit the access of vehicles to only those roads and parking areas that are stabilized

Design and Installation Specifications.

- Construct on level ground where possible

- On areas that will receive asphalt as part of the project, install the first lift as soon as possible
- A 6-inch depth of 2- to 4-inch crushed rock, gravel base, or crushed surfacing base course shall be applied immediately after grading or utility installation. A 4-inch course of asphalt treated base (ATB) may also be used, or the road/parking area may be paved. It may also be possible to use cement or calcium chloride for soil stabilization. If cement or cement kiln dust is used for road base stabilization, pH monitoring and BMPs are necessary to evaluate and minimize the effects on stormwater. If the area will not be used for permanent roads, parking areas, or structures, a 6-inch depth of hog fuel may also be used, but this is likely to require more maintenance. Whenever possible, construction roads and parking areas shall be placed on a firm, compacted subgrade
- Temporary road gradients shall not exceed 15%. Roadways shall be carefully graded to drain. Drainage ditches shall be provided on each side of the roadway in the case of a crowned section, or on one side in the case of a super-elevated section. Drainage ditches shall be directed to a sediment control BMP
- Rather than relying on ditches, it may also be possible to grade the road so that runoff sheet-flows into a heavily vegetated area with well-developed topsoil. Landscaped areas are not adequate. If this area has at least 50 feet of vegetation, then it is generally preferable to use the vegetation to treat runoff, rather than a sediment pond or trap. The 50 feet shall not include wetlands. If runoff is allowed to sheet flow through adjacent vegetated areas, it is vital to design the roadways and parking areas so that no concentrated runoff is created
- Storm drain inlets shall be protected to prevent sediment-laden water entering the storm drain system (see BMP SC-4)

Maintenance Standards.

- Inspect stabilized areas regularly, especially after large storm events
- Crushed rock, gravel base, hog fuel, etc. shall be added as required to maintain a stable driving surface and to stabilize any areas that have eroded
- Following construction, these areas shall be restored to pre-construction condition or better to prevent future erosion

7. BMP EC-7: Dust and Wind Erosion Control.

Purpose. Dust control prevents wind transport of dust from disturbed soil surfaces onto roadways, drainage ways, and surface waters. Wind erosion or dust control consists of applying water or other dust palliatives as necessary to prevent or alleviate dust nuisance generated by construction activities. Covering small stockpiles or areas is an alternative to applying water or other dust palliatives.

Conditions of Use.

In areas (including roadways) subject to surface and air movement of dust where on-site and off-site impacts to roadways, drainage ways, or surface waters are likely. Wind erosion control BMPs are suitable during the following construction activities:

- Construction vehicle traffic on unpaved roads
- Drilling and blasting activities
- Sediment tracking onto paved roads
- Soils and debris storage piles
- Batch drop from front-end loaders
- Areas with unstabilized soil
- Final grading/site stabilization

Limitations.

- Water prevents dust only for a short period and should be applied daily (or more often) to be effective
- Over watering may cause erosion
- Oil or oil-treated subgrade should not be used for dust control because the oil may migrate into drainage ways and/or seep into the soil
- Effectiveness depends on soil, temperature, humidity, and wind velocity
- Chemically treated subgrades may make the soil water repellent, interfering with long-term infiltration and the vegetation/re-vegetation of the site. Some chemical dust suppressants may be subject to freezing, may contain solvents, and should be handled properly
- Asphalt, as a mulch tack or chemical mulch, requires a 24-hour curing time to avoid adherence to equipment, worker shoes, etc. Application should be limited because asphalt surfacing may eventually migrate into the drainage system
- In compacted areas, watering and other liquid dust control measures may wash sediment or other constituents into the drainage system

Planning Criteria.

1. Plan and schedule work to open the least amount of land possible at one time. Surface disturbances should be stabilized or reclaimed before additional land is disturbed.
2. Install permanent erosion control measures as soon as construction or development work is completed.
3. The irrigation water supply should be developed before land is opened so that water is available for establishing vegetation.

4. When possible, schedule construction and development operations during months with the least wind erosion hazard. This is usually during later summer through fall.

Design and Installation Specifications.

- Vegetate or mulch areas that will not receive vehicle traffic. In areas where planting, mulching, or paving is impractical, apply gravel or landscaping rock
- Limit dust generation by clearing only those areas where immediate activity will take place, leaving the remaining area(s) in the original condition, if stable. Maintain the original ground cover as long as practical
- Construct natural or artificial windbreaks or windscreens. These may be designed as enclosures for small dust sources
- Sprinkle the site with water until surface is wet. Repeat as needed. To prevent carryout of mud onto street, refer to Stabilized Construction Entrance (BMP SC-1)
- Irrigation water can be used for dust control. Irrigation systems should be installed as a first step on sites where dust control is a concern
- Spray exposed soil areas with a dust palliative, following the manufacturer's instructions and cautions regarding handling and application. Used oil is prohibited from use as a dust suppressant. Local governments may approve other dust palliatives such as calcium chloride or PAM
- PAM (BMP EC-19) added to water at a rate of 0.5 lbs. per 1,000 gallons of water per acre and applied from a water truck is more effective than water alone. This is due to the increased infiltration of water into the soil and reduced evaporation. In addition, small soil particles are bonded together and are not as easily transported by wind
- Adding PAM may ~~[actually]~~ reduce the quantity of water needed for dust ~~[control. Since the wholesale cost of PAM is about \$ 4.00 per pound, this is an extremely cost effective]~~ **and may be a cost-effective** dust control method
- Dust control BMPs generally stabilize exposed surfaces and minimize activities that suspend or track dust particles. The following table shows dust control practices that can be applied to site conditions that cause dust

Site Condition	Dust Control Practices								
	Permanent Vegetation	Mulching	Wet Suppression (Watering)	Chemical Dust Suppression	Gravel or Asphalt	Silt Fences	Temporary Gravel Construction Entrances/Equipment	Haul Truck Covers	Minimize Extent of Disturbed Area
Disturbed Areas not Subject to Traffic	X	X	X	X	X				X
Disturbed Areas Subject to Traffic			X	X	X		X		X
Material Stock Pile Stabilization			X	X		X			X
Demolition			X				X	X	
Clearing/Excavation			X	X		X			X
Truck Traffic on Unpaved Roads			X	X	X		X	X	
Mud/Dirt Carry Out					X		X		

Techniques that can be used for unpaved roads and lots include:

- Lower speed limits. High vehicle speed increases the amount of dust stirred up from unpaved roads and lots
- Upgrade the road surface strength by improving particle size, shape, and mineral types that make up the surface and base materials
- Add surface gravel to reduce the source of dust emission. Limit the amount of fine particles (those smaller than .075 mm) to 10 to 20%
- Use geotextile fabrics to increase the strength of new roads or roads undergoing reconstruction
- Encourage the use of alternate paved routes, if available
- Restrict use by tracked vehicles and heavy trucks to prevent damage to road surface and base
- Apply chemical dust suppressants using the admix method, blending the product with the top few inches of surface material. Suppressants may also be applied as surface treatments
- Pave unpaved permanent roads and other trafficked areas
- Use vacuum street sweepers
- Remove mud and other dirt promptly so it does not dry and then turn into dust
- Limit dust-causing work on windy days

- Contact your local Air Pollution Control Authority for guidance and training on other dust control measures. Compliance with the local Air Pollution Control Authority constitutes compliance with this BMP

Additional preventive measures include:

- Schedule construction activities to minimize exposed area
- Limit onsite vehicle traffic to 15 mph
- Control the number and activity of vehicles on a site at any given time
- Identify and stabilize key access points prior to commencement of construction
- Minimize the impact of dust by anticipating the direction of prevailing winds
- Direct most construction traffic to stabilized roadways within the project site
- Water should be applied by means of pressure-type distributors or pipelines equipped with a spray system or hoses and nozzles that will ensure even distribution
- All distribution equipment should be equipped with a positive means of shutoff
- Unless water is applied by means of pipelines, at least one mobile unit should be available at all times to apply water or dust palliative to the project
- If reclaimed wastewater is used, non-potable water should not be conveyed in tanks or drainpipes that will be used to convey potable water and there should be no connection between potable and non-potable supplies
- Materials applied as temporary soil stabilizers and soil binders also generally provide wind erosion control benefits
- Pave or chemically stabilize access points where unpaved traffic surfaces adjoin paved roads
- Provide covers for haul trucks transporting materials that contribute to dust
- Provide for wet suppression or chemical stabilization of exposed soils
- Provide for rapid clean up of sediments deposited on paved roads. Furnish stabilized construction road entrances and vehicle wash down areas
- Stabilize inactive construction sites using vegetation or chemical stabilization methods

Inspection and Maintenance.

- Inspect and verify that activity-based BMPs are in place prior to the commencement of associated activities. While activities associated with the BMP are under way, inspect weekly during the rainy season and at two-week intervals in the non-rainy season to verify continued BMP implementation
- Regular maintenance is critical to effective dust control, whether temporary or permanent measures are being utilized. Most dust control measures require frequent, often daily, or multiple times per day attention

- Regular water applications are necessary given specific site conditions.
Mulches should be replaced or reapplied as necessary
- Vegetative cover should be established and maintained on surface disturbance areas Check areas protected to ensure coverage
- Keep windbreak and barriers in good conditions by repairing or replanting any openings
- Protect sensitive areas from additional surface disturbances

Effectiveness. Dust control will reduce sediment delivery by runoff waters, control degradation of water in nearby streams from windblown sediments and minimize the loss of topsoil.

8. BMP EC-8: Level Spreader.

Purpose. To convert concentrated flows into sheet flow for surface application at non-erosive velocities onto stabilized areas. To provide a temporary outlet for dikes and diversions consisting of an excavated depression constructed at zero grade across a slope.

Conditions of Use.

- Used when a concentrated flow of water needs to be dispersed over a large area with existing stable vegetation
- Items to consider are:
 1. What is the risk of erosion or damage if the flow may become concentrated?
 2. Is an easement required if discharged to adjoining property?
 3. Most of the flow should be as ground water and not as surface flow
 4. Is there an unstable area downstream that cannot accept additional ground water?
- Use only where the slopes are gentle, the water volume is relatively low, and the soil will adsorb most of the low flow events

Planning Criteria. Detailed design is not required, but extreme care must be used during construction to ensure that the outlet lip is exactly level and uniform from end to end. Failure to meet these requirements will cause concentrated flow and consequent erosion of the stabilized area. The excavation for the spreader should be on well-stabilized soils (vegetated or rock armored).

Determine through topographical mapping the length and degree of slope, contributing watershed and associated drainage ways. Baseline soils data should be gathered and analyzed for [~~erodability~~] **erodibility**.

Design and Installation Specifications.

- Use above undisturbed areas that are stabilized by existing vegetation
- Runoff to the spreader should be from areas that have been stabilized to eliminate sediment buildup in the spreader

- If the level spreader has any low points, flow will concentrate, create channels and may cause erosion
- Discharge area below the outlet must be uniform with a slope of less than 5H: 1V
- Outlet to be constructed level in a stable, undisturbed soil profile (not on fill)
- The runoff shall not concentrate after release unless intercepted by another downstream measure
- The grade of the channel for the last 20 feet of the dike or interceptor entering the level spreader shall be less than or equal to 1%. The grade of the level spreader shall be 0% to ensure uniform spreading of storm runoff
- A 6-inch high gravel berm placed across the level lip shall consist of washed crushed rock, 2- to 4-inch or ¾-inch to 1½-inch size
- The spreader length shall be determined by estimating the peak flow expected from the 10-year, 24-hour design storm. The length of the spreader shall be a minimum of 15 feet for 0.1 cfs and shall be 10 feet for each 0.1 cfs there after to a maximum of 0.5 cfs per spreader. Use multiple spreaders for higher flows
- The width of the spreader should be at least 6 feet
- The depth of the spreader as measured from the lip should be at least 6 inches and it should be uniform across the entire length
- Level spreaders shall be setback from the property line unless there is an easement for flow
- Level spreaders, when installed every so often in grassy swales, keep the flows from concentrating. Materials that can be used include sand bags, lumber, logs, concrete, and pipe. To function properly, the material needs to be installed level and on contour

Maintenance Standards.

- The spreader should be inspected and repaired as necessary after every runoff event to ensure that it is functioning correctly
- Remove sediment as necessary
- The contractor should avoid the placement of any material on the structure and should prevent construction traffic from crossing over the structure
- If the spreader is damaged by construction traffic, it shall be immediately repaired

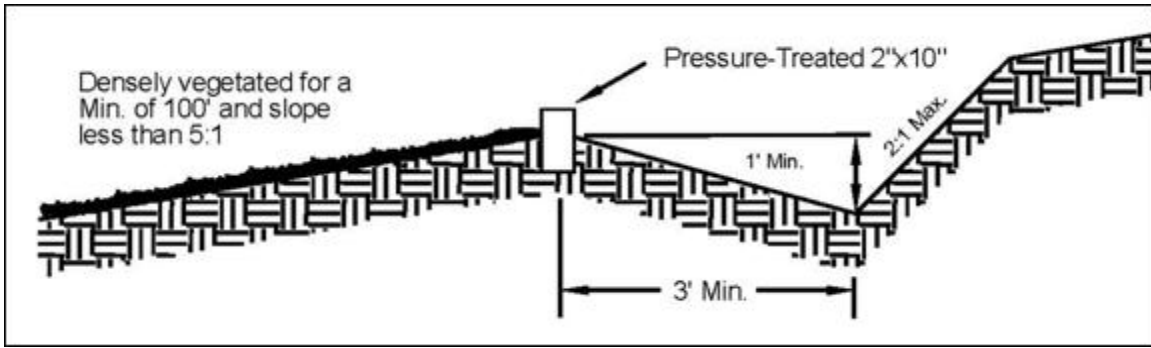

FIGURE EC-8-1 CROSS SECTION OF LEVEL SPREADER

From: Stormwater Management Manual for Western Washington, Washington Department of Ecology, 2001

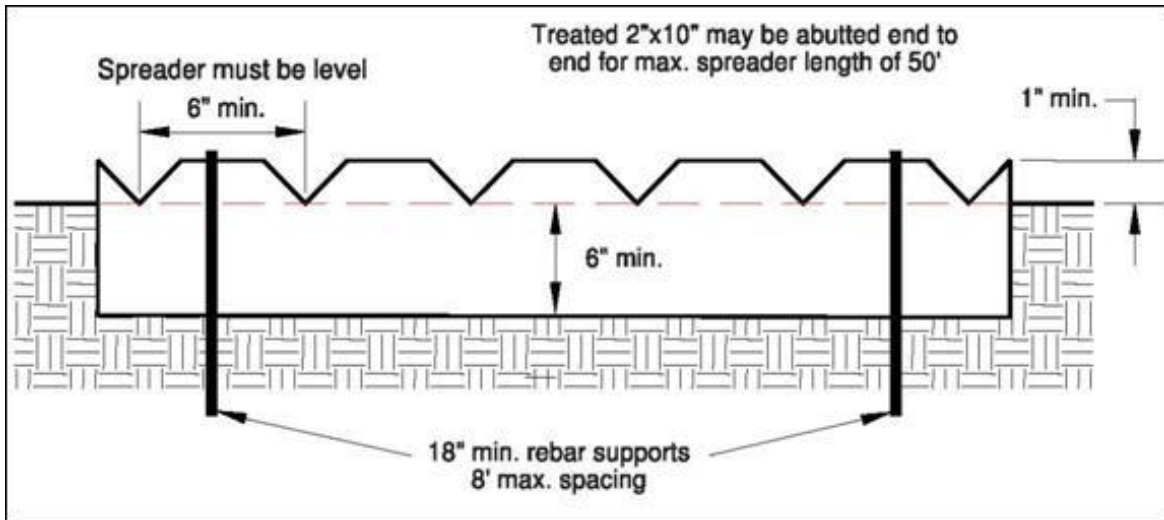

FIGURE EC-8-2 DETAIL OF LEVEL SPREADER

From: Stormwater Management Manual for Western Washington, Washington Department of Ecology, 2001

9. BMP EC-9: Subsurface Drains.

Purpose. To intercept, collect, and convey ground water to a satisfactory outlet, using a perforated pipe or conduit below the ground surface. Subsurface drains are also known as [~~French~~] **“French drains.”** The perforated pipe provides a dewatering mechanism to drain excessively wet soils, provides a stable base for construction, improves stability of structures with shallow foundations, and reduces hydrostatic pressure to improve slope stability.

Conditions of Use. Use when excessive water must be removed from the soil. The soil permeability, depth to water table and impervious layers are all factors which may govern the use of subsurface drains.

Design and Installation Specifications.

- Relief drains are used either to lower the water table in large, relatively flat areas, improve the growth of vegetation, or to remove surface water. They are installed along a slope and drain in the direction of the slope. They can be installed in a grid pattern, a herringbone pattern, or a random pattern

- Interceptor drains are used to remove excess ground water from a slope, stabilize steep slopes, and lower the water table immediately below a slope to prevent the soil from becoming saturated. They are installed perpendicular to a slope and drain to the side of the slope. They usually consist of a single pipe or series of single pipes instead of a patterned layout
- Depth and spacing of interceptor drains - The depth of an interceptor drain is determined primarily by the depth to which the water table is to be lowered or the depth to a confining layer. For practical reasons, the maximum depth is usually limited to 6 feet, with a minimum cover of 2 feet to protect the conduit
- The soil should have depth and sufficient permeability to permit installation of an effective drainage system at a depth of 2 to 6 feet
- An adequate outlet for the drainage system must be available either by gravity or by pumping
- The quantity and quality of discharge needs to be accounted for in the receiving stream (additional detention may be required)
- This standard does not apply to subsurface drains for building foundations or deep excavations
- The capacity of an interceptor drain is determined by calculating the maximum rate of ground water flow to be intercepted. Therefore, it is good practice to make complete subsurface investigations, including hydraulic conductivity of the soil, before designing a subsurface drainage system
- Size of drain - Size subsurface drains to carry the required capacity without pressure flow. Minimum diameter for a subsurface drain is 4 inches
- The minimum velocity required to prevent silting is [1-4] 2 ft./sec. The line shall be graded to achieve this velocity at a minimum. The maximum allowable velocity using a sand-gravel filter or envelope is 9 ft/sec. Filter material and fabric shall be used around all drains for proper bedding and filtration of fine materials. Envelopes and filters should surround the drain to a minimum of 3-inch thickness
- The outlet of the subsurface drain shall empty into a sediment pond through a catch basin. If free of sediment, it can then empty into a receiving channel, swale, or stable vegetated area adequately protected from erosion and undermining
- The trench shall be constructed on a continuous grade with no reverse grades or low spots
- Soft or yielding soils under the drain shall be stabilized with gravel or other suitable material
- Backfilling shall be done immediately after placement of the pipe. No sections of pipe shall remain uncovered overnight or during a rainstorm. Backfill

material shall be placed in the trench in such a manner that the drainpipe is not displaced or damaged

- Do not install permanent drains near trees to avoid the tree roots that tend to clog the line. Use solid pipe with watertight connections where it is necessary to pass a subsurface drainage system through a stand of trees
- Outlet - Ensure that the outlet of a drain empties into a channel or other watercourse above the normal water level
- Secure an animal guard to the outlet end of the pipe to keep out rodents
- Use outlet **material comprising reinforced concrete** pipe [~~of corrugated metal, cast iron,~~] or heavy-duty plastic, **including PVC/HDPE**, without perforations and at least 10 feet long. Do not use an envelope or filter material around the outlet pipe, and bury at least two-thirds of the pipe length
- When outlet velocities exceed those allowable for the receiving stream, outlet protection must be provided

Maintenance Standards.

- Subsurface drains shall be checked periodically to ensure that they are free-flowing and not clogged with sediment or roots
- The outlet shall be kept clean and free of debris
- Surface inlets shall be kept open and free of sediment and other debris
- Trees located too close to a subsurface drain often clog the system with their roots. If a drain becomes clogged, relocate the drain or remove the trees as a last resort. Drain placement should be planned to minimize this problem
- Where drains are crossed by heavy vehicles, the line shall be checked to ensure that it is not crushed

10. BMP EC-10: Pipe Slope Drains.

Purpose. A slope drain is a pipe used to intercept and direct surface runoff or groundwater into a stabilized watercourse, trapping device, or stabilized area. Slope drains are used with earth dikes and drainage ditches to intercept and direct surface flow away from slope areas to protect cut or fill slopes.

Conditions of Use.

- Pipe slope drains should be used when a temporary or permanent stormwater conveyance is needed to move the water down a steep slope to avoid erosion
- Drainage for top of slope diversion dikes or swales
- Drainage for top of cut and fill slopes where water can accumulate
- Emergency spillway for a sediment basin
- Collect clean runoff from plastic sheeting and direct it away from exposed soil
- Installed in conjunction with silt fence to drain collected water to a controlled area

- Used to divert small seasonal streams away from construction. They have been used successfully on culvert replacement and extension jobs. Large flex pipe can be used on larger streams during culvert removal, repair, or replacement
- Connected to existing down spouts and roof drains and used to divert water away from work areas during building renovation, demolition, and construction projects There are several commercially available collectors that are attached to the pipe inlet and help prevent erosion at the inlet

Design and Installation Specifications.

- Permanent structures included in the project plans can often serve as construction BMPs if implemented early. However, the permanent structure must meet or exceed the criteria for the temporary structure
- Size the pipe to convey the flow. The capacity for temporary drains shall be sufficient to handle the peak flow from a 10-year, 24-hour storm event. Permanent pipe slope drains shall be sized for the 25-year, 24-hour peak flow
- Use care in clearing vegetated slopes for installation
- Re-establish cover immediately on areas disturbed by installation
- Use temporary drains on new cut or fill slopes
- Use diversion dikes or swales to collect water at the top of the slope
- Install slope drains perpendicular to slope contours
- Ensure that the entrance area is stable and large enough to direct flow into the pipe
- The entrance shall consist of a standard flared end section for culverts 12 inches and larger with a minimum 6-inch metal toe plate to prevent runoff from undercutting the pipe inlet. The slope of the entrance shall be at least 3%. Sand bags may also be used at pipe entrances as a temporary measure
- Debris racks are recommended at the inlet. Debris racks located several feet upstream of the inlet can usually be larger than racks at the inlet, and thus provide enhanced debris protection and less plugging
- Safety racks are recommended at the inlet and outlet of pipes where children or animals could become trapped
- The soil around and under the pipe and entrance section shall be thoroughly compacted to prevent undercutting and gully erosion
- The flared inlet section shall be securely connected to the slope drain and have watertight connecting bands
- Slope drain sections shall be securely fastened together, fused or have gasketed watertight fittings, and shall be securely anchored into the soil
- Thrust blocks should be installed anytime 90 degree bends are utilized. Depending on size of pipe and flow, these can be constructed with sand bags, straw bales staked in place, "t" posts and wire, or ecology blocks

- Pipe needs to be secured along its full length to prevent movement. This can be done with steel "t" posts and wire. A post is installed on each side of the pipe and the pipe is wired to them. This should be done every 10-20 feet of pipe length or so, depending on the size of the pipe and quantity of water to diverted
- Interceptor dikes shall be used to direct runoff into a slope drain. The height of the dike shall be at least 1 foot higher at all points than the top of the inlet pipe
- The area below the outlet must be stabilized with a riprap apron (see BMP EC-13 Outlet Protection, for the appropriate outlet material)
- If the pipe slope drain is conveying sediment-laden water, direct all flows into the sediment trapping facility
- Recommended materials [include both metal and plastic pipe, either corrugated or smooth wall] **comprising reinforced concrete pipe or heavy-duty plastic, including PVC/HDPE**

Maintenance Standards.

- Check inlet and outlet points regularly, especially after storms
- The inlet should be free of undercutting, and no water should be going around the point of entry. If there are problems, the headwall should be reinforced with compacted earth or sand bags
- The outlet point should be free of erosion and installed with appropriate outlet protection
- For permanent installations, inspect pipe periodically for vandalism and physical distress such as slides and wind-throw
- Normally the pipe slope is so steep that clogging is not a problem with smooth wall pipe, however, debris may become lodged in the pipe

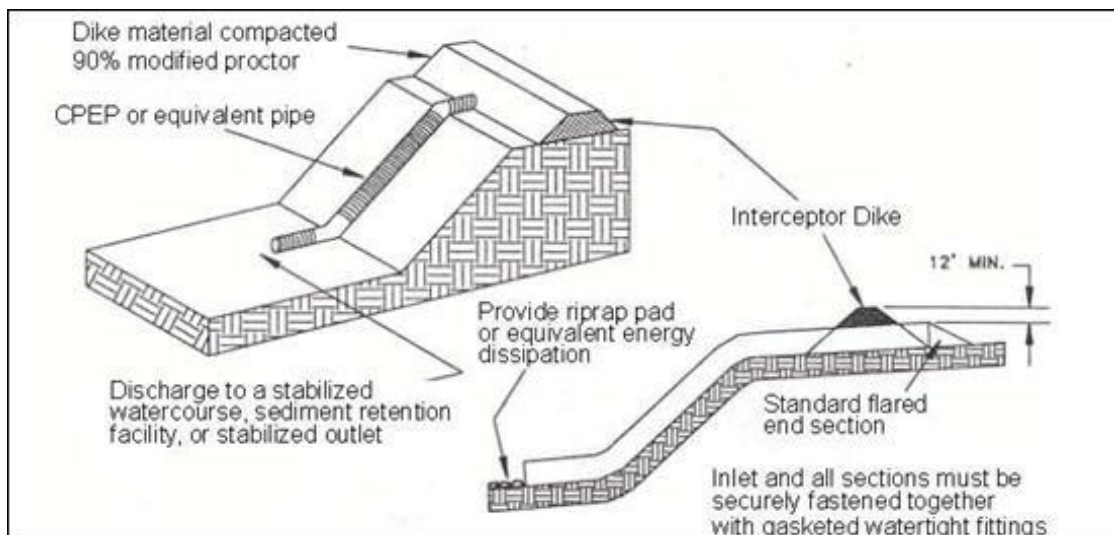

FIGURE EC-10-1 PIPE SLOPE DRAIN

11. BMP EC-11: Channel Lining.

Purpose. To protect erodible channels by providing a channel liner using either blankets or riprap.

Conditions of Use.

- When natural soils or vegetated stabilized soils in a channel are not adequate to prevent channel erosion
- When a permanent ditch or pipe system is to be installed and a temporary measure is needed
- ~~[In almost all cases, synthetic and organic coconut blankets are more effective than riprap for protecting channels from erosion.]~~ Blankets can be used with and without vegetation. Blanketed channels can be designed to handle any expected flow and longevity requirement. Some synthetic blankets have a predicted life span of 50 years or more, even in sunlight
- ~~[Other reasons]~~ **An additional reason** why blankets are ~~[better than]~~ **are selected in lieu of** rock ~~[include]~~ **is** the availability of blankets ~~[over rock]~~. Blankets can be delivered anywhere. Rock requires the use of dump trucks to haul and heavy equipment to place. Blankets usually only require laborers with hand tools, and sometimes a backhoe
- The Federal Highway Administration recommends not using flexible liners whenever the slope exceeds 10% or the shear stress exceeds 8 lbs/ft²

Design and Installation.

- See EC-17 for information on blankets
- Disturbance of areas where riprap is to be placed should be undertaken only when final preparation and placement of the riprap can follow immediately behind the initial disturbance. Where riprap is used for outlet protection, the riprap should be placed before or in conjunction with the construction of the pipe or channel so that it is in place when the pipe or channel begins to operate. **Riprap should be placed in a manner such that it does not protrude above the invert of the outlet.**
- Determine the riprap size that will be stable under the flow conditions. Based on riprap gradations actually available in the area, select the size or sizes that equal or exceed the minimum size. The possibility of drainage structure damage by children shall be considered in selecting a riprap size, especially if there is nearby water or a gully in which to toss the stones
- Stone for riprap shall consist of fieldstone or quarry stone of approximately rectangular shape. The stone shall be hard and angular and of such quality that it will not disintegrate on exposure to water or weathering and it shall be suitable in all respects for the purpose intended

- Rubble concrete may be used provided it has a density of at least 150 pounds per cubic foot, and otherwise meets the requirement of this standard and specification
- A lining of engineering filter fabric (geotextile) shall be placed between the riprap and the underlying soil surface to prevent soil movement into or through the riprap. The geotextile should be keyed in at the top of the bank
- Filter fabric shall not be used on slopes greater than 1-1/2:1 as slippage may occur
- Filter fabric should be used in conjunction with a layer of coarse aggregate (granular filter blanket) when the riprap to be placed is 12 inches and larger

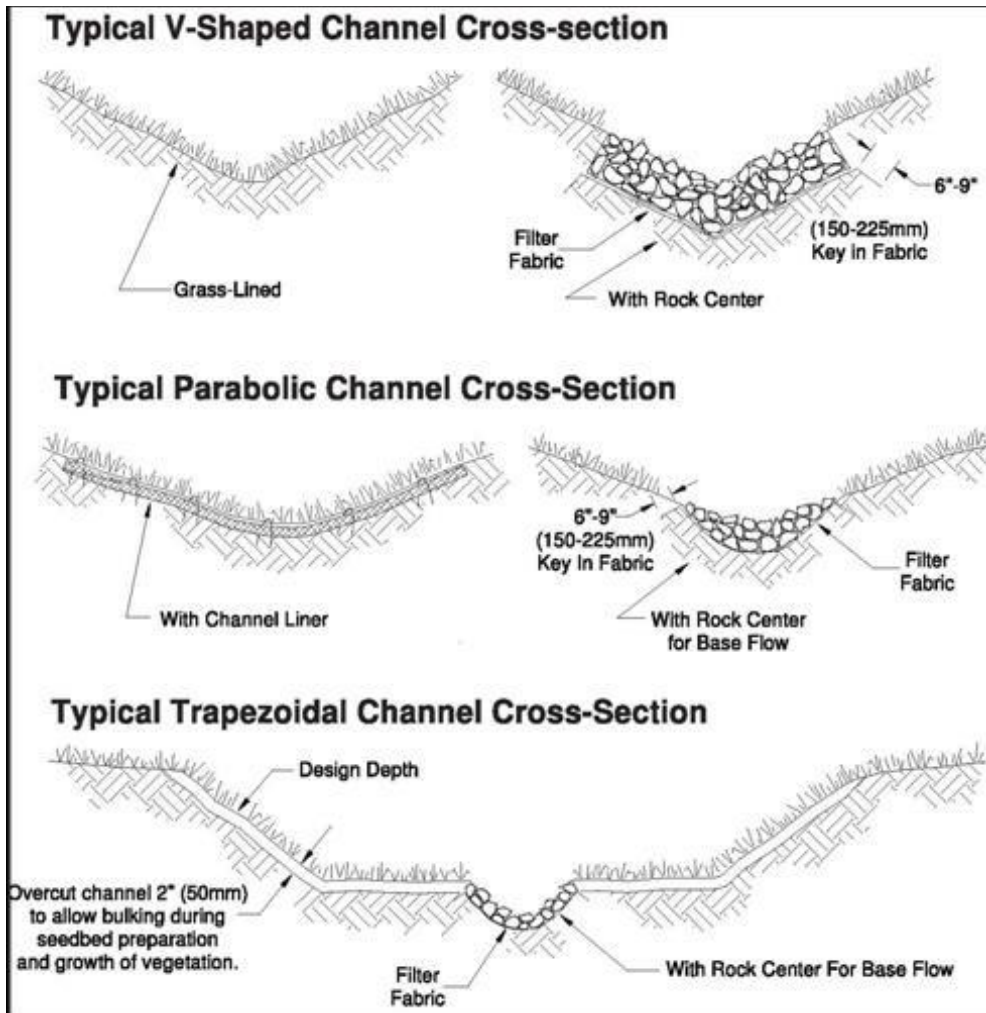

FIGURE EC-11-1 TYPICAL GRASS-LINED CHANNELS

From: Stormwater Management Manual for Western Washington, Washington Department of Ecology, 2001

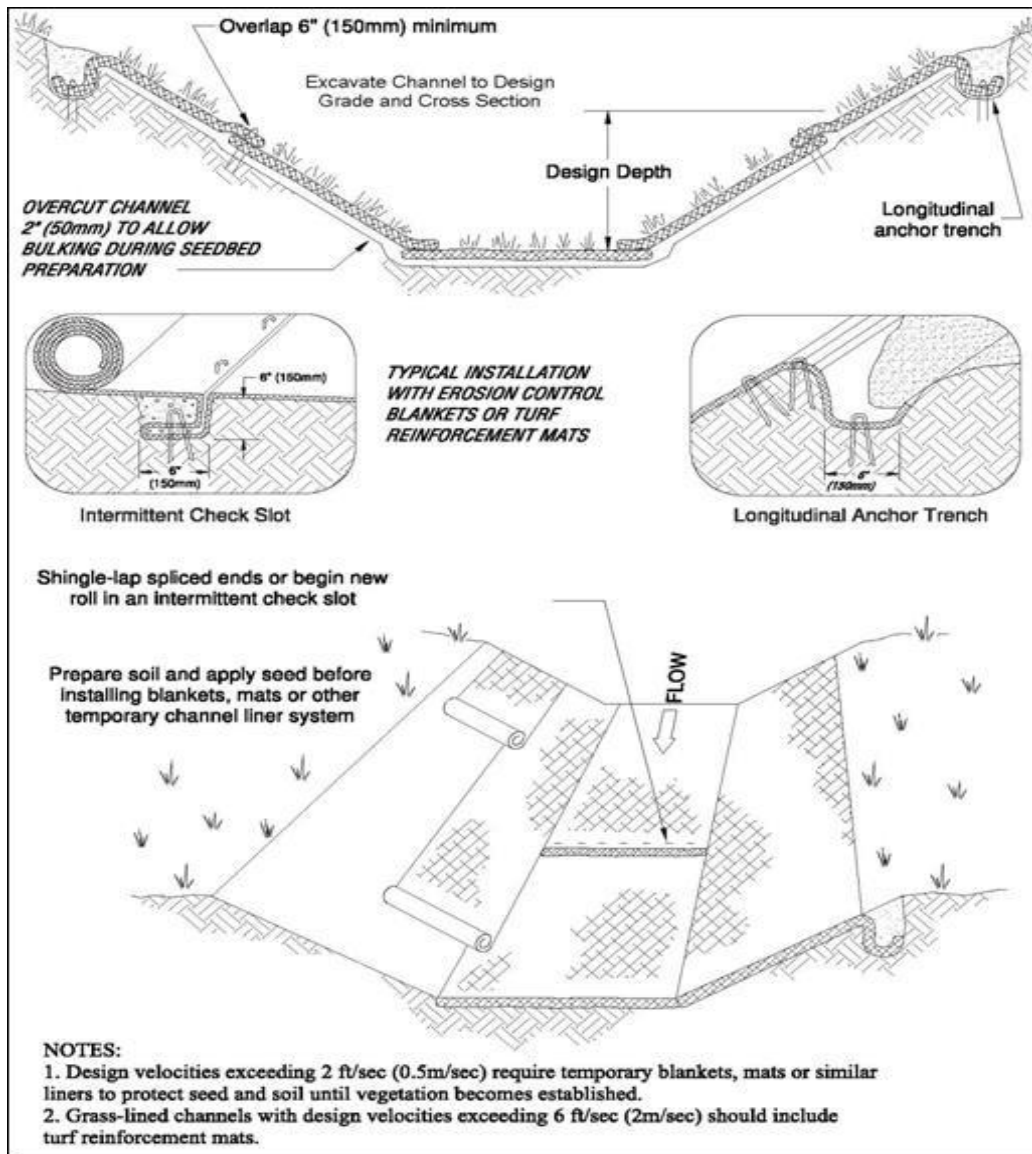

FIGURE EC-11-2 TEMPORARY CHANNEL LINERS

From: Stormwater Management Manual for Western Washington, Washington Department of Ecology, 2001

12. BMP EC-12: Grassed Waterways and Outlets

Purpose. A grassed waterway is a natural or constructed waterway or outlet with a vegetative cover of adapted grasses for safe disposal of runoff water without erosion.

Conditions of Use.

- This practice applies to construction sites where concentrated runoff needs to be contained to prevent erosion or flooding and where soil and site conditions are suitable for establishing adequate grass cover
- When channel slopes are generally less than 5% and space is available for a relatively large cross section

- Typical uses include roadside ditches, channels at property boundaries, outlets for diversions, and other channels and drainage ditches in low areas
- Channels that will be vegetated should be installed before major earthwork and hydroseeded with a bonded fiber mulch (BFM). The vegetation should be well established [~~i.e., 75% cover~~] **, such as with percent cover,** before water is allowed to flow in the ditch. With channels that will have high flows, erosion control blankets should be installed over the hydroseed. If vegetation cannot be established from seed before water is allowed in the ditch, [~~sod~~] **accepted alternatives** should be installed in the bottom of the ditch in lieu of hydromulch and blankets
- The grass species selected must be appropriate for the Carson City area. Moisture from natural precipitation or irrigation must be adequate to establish and maintain good grass cover

Design and Installation Specifications.

- Locate the channel where it can conform to the topography and other features such as roads
- Locate them to use natural drainage systems to the greatest extent possible
- Avoid sharp changes in alignment or bends and changes in grade
- Do not reshape the landscape to fit the drainage channel
- Design velocities are to be below 5 ft/sec.; however, the design velocity should be based on soil conditions, type of vegetation, and method of establishment
- An established grass or vegetated lining is required before the channel can be used to convey stormwater, unless stabilized with nets or blankets
- If design velocity of a channel to be vegetated by seeding exceeds 2 ft/sec, a temporary channel liner is required. Geotextile or special mulch protection such as fiberglass roving or straw and netting provide stability until the vegetation is fully established
- Check dams shall be removed when the grass has matured sufficiently to protect the ditch or swale unless the slope of the swale is greater than 4%. The area beneath the check dams shall be seeded and mulched immediately after dam removal
- [~~If vegetation is established by sodding, the permissible velocity for established vegetation may be used and no temporary liner is needed~~]
- Do not subject grass-lined channel to sedimentation from disturbed areas. Use sediment-trapping BMPs upstream of the channel
- V-shaped grass channels generally apply where the quantity of water is small, such as in short reaches along roadsides. The V-shaped cross section is least desirable because it is difficult to stabilize the bottom where velocities may be high

- Trapezoidal grass channels are used where runoff volumes are large and slope is low so that velocities are nonerosive to vegetated linings. (Note: it is difficult to construct small parabolic shaped channels)
- Provide outlet protection at culvert ends and at channel intersections
- Grass channels, at a minimum, should carry peak runoff for temporary construction drainage facilities from the 10-year, 24-hour storm without eroding. Where flood hazard exists, increase the capacity according to the potential damage
- Grassed channel side slopes generally are constructed 3:1 or flatter to aid in the establishment of vegetation and for maintenance
- Construct channels a minimum of 0.2 foot larger around the periphery to allow for soil bulking during seedbed preparations and sod buildup

Maintenance Standards.

- During the establishment period, check grass-lined channels after every rainfall.
- After grass is established, periodically check the channel; check it after every heavy rainfall event. Immediately make repairs
- It is particularly important to check the channel outlet and all road crossings for bank stability and evidence of piping or scour holes
- Remove all significant sediment accumulations to maintain the designed carrying capacity. Keep the grass in a healthy, vigorous condition at all times, since it is the primary erosion protection for the channel
- Protect waterways from excessive grazing and vehicle use
- Keep waterway clear of debris, brush, and excess growth
- Fertilize as needed to maintain grass stand and plant vigor
- Reseed any damaged or open areas in the grass cover

13. BMP EC-13: Outlet Protection.

Purpose. Outlet protection prevents scour at conveyance outlets and minimizes the potential for downstream erosion by reducing the velocity of concentrated stormwater flows.

Conditions of use. Outlet protection is required at the outlets of all ponds, pipes, ditches, or other conveyances, and where runoff is conveyed to a natural or manmade drainage feature such as a stream, wetland, or ditch when discharge velocities and energies at the outlet are sufficient to erode the immediate downstream reach. The outlet protection is a physical device composed of rock, grouted riprap, or concrete rubble, placed at the outlet of a pipe or channel to prevent scour of the soil caused by concentrated, high velocity flows. **Riprap should be placed in a manner such that it does not protrude above the invert of the outlet.**

Design and Installation Specifications.

- The receiving channel at the outlet of a culvert shall be protected from erosion by rock lining a minimum of 6 feet downstream and extending up the channel sides a minimum of 1-foot above the maximum tailwater elevation or 1-foot above the crown, whichever is higher. For large pipes (more than 18 inches in diameter), the outlet protection lining of the channel is lengthened to four times the diameter of the culvert
- Standard wing walls, and tapered outlets and paved channels should also be considered when appropriate for permanent culvert outlet protection. However, rock outlet protection is usually less expensive and easier to install than concrete aprons or energy dissipaters. Rock can also serve to trap sediment and reduce flow velocities
- Organic or synthetic erosion [~~blankets, with or without vegetation, are usually more effective than rock, cheaper, and easier to install. Materials can be chosen~~] **blankets may be selected** using manufacturer product specifications. ASTM test results are available for most products and the designer can choose the correct material for the expected flow
- With low flows, vegetation (including sod) can be effective
- The following guidelines shall be used for riprap outlet protection:
 1. If the discharge velocity at the outlet is less than 5 fps (pipe slope less than 1%), use 2-inch to 8-inch riprap. Minimum thickness is 1-foot.
 2. For 5 to 10 fps discharge velocity at the outlet (pipe slope less than 3%), use 24-inch to 4-foot riprap. Minimum thickness is 2 feet.
 3. For outlets at the base of steep slope pipes (pipe slope greater than 3%), an engineered energy dissipater shall be used.
- Filter fabric or erosion control blankets should always be used under riprap to prevent scour and channel erosion
- For proper operation of apron, align apron with receiving stream and keep straight throughout its length. If a curve is needed to fit site conditions, place it in upper section of apron

Maintenance Standards.

- Inspect BMP [~~prior to forecast~~] **before forecasted** rain, daily during extended rain events, after rain events, weekly during the rainy season, and at two-week intervals during the non-rainy season
- Inspect apron for displacement of the riprap and damage to the underlying fabric. Repair fabric and replace riprap that has washed away. If riprap continues to wash away, consider using larger material
- Inspect for scour beneath the riprap and around the outlet. Repair damage to slopes or underlying filter fabric immediately
- Clean energy dissipater if sediment builds up

- Remove temporary devices as soon as the surrounding drainage area has been stabilized or at the completion of construction

14. BMP EC-14: Check Dams.

Purpose. Construction of small dams across a swale or ditch reduces the velocity of concentrated flow and dissipates energy at the check dam. Check dams reduce the effective slope of the channel, thereby reducing the velocity of flowing water, allowing sediment to settle and reducing erosion. Check dams also help keep the flow spread evenly across the bottom of wide trapezoidal cross sections, thus helping to prevent scouring.

Conditions of Use.

- Where temporary channels or permanent channels are not yet vegetated, channel lining is infeasible, and velocity checks are required
- To promote sedimentation behind the dam
- To prevent erosion by reducing the velocity of channel flow in small intermittent channels and temporary swales
- In small open channels that drain 10 acres or less
- In steep channels where stormwater runoff velocities exceed 5 ft/s
- In wide trapezoidal cross sections to keep flow spread evenly

Limitations.

- Not to be used in live streams or in channels with extended base flows
- Not appropriate in channels that drain areas greater than 10 acres
- Not appropriate in channels that are already grass-lined unless erosion is expected, as installation may damage vegetation
- Require extensive maintenance following high velocity flows
- Promotes sediment trapping which can be re-suspended during subsequent storms or removal of the check dam

Design and Installation Specifications.

- Whatever material is used, the dam should form a triangle when viewed from the side. This prevents undercutting as water flows over the face of the dam rather than falling directly onto the ditch bottom
- Check dams in association with sumps work more effectively at slowing flow and retaining sediment than just a check dam alone. A deep sump should be provided immediately upstream of the check dam
- In some cases, if carefully located and designed, check dams can remain as permanent installations with very minor regrading. They may be left as either spillways, in which case accumulated sediment would be graded and seeded, or as check dams to prevent further sediment from leaving the site

- Check dams can be constructed of either rock or pea-gravel filled bags. Numerous products are also available for this purpose. They tend to be reusable, quick and easy to install, effective, and cost efficient
- Design check dams so that the capacity of the waterway remains adequate for the design flow
- Check dams should be placed perpendicular to the flow of water
- The maximum spacing between the dams shall be such that the toe of the upstream dam is at the same elevation as the top of the downstream dam
- Keep the maximum height at 2 feet at the center of the dam
- Keep the center of the check dam at least 12 inches lower than the outer edges at natural ground elevation
- Keep the side slopes of the check dam at 2:1 or flatter
- Key the stone into the ditch banks and extend it beyond the abutments a minimum of 18 inches to avoid washouts from overflow around the ends of the dam
- Use filter fabric foundation under a rock or sand bag check dam. If a blanket ditch liner is used, this is not necessary. A piece of organic or synthetic blanket cut to fit will also work for this purpose
- Rock check dams shall be constructed of appropriately sized rock. The rock must be placed by hand or by mechanical means (no dumping of rock to form dam) to achieve complete coverage of the ditch or swale and to ensure that the center of the dam is lower than the edges. The rock used must be large enough to stay in place given the expected design flow velocities through the channel
- In the case of grass-lined ditches and swales, all check dams and accumulated sediment shall be removed when the grass has matured sufficiently to protect the ditch or swale - unless the slope of the swale is greater than 4%. The area beneath the check dams shall be seeded and mulched immediately after dam removal
- Ensure that channel appurtenances, such as culvert entrances below check dams, are not subject to damage or blockage from displaced stones

Maintenance Standards.

- Inspect BMPs [~~prior to forecast~~] **before forecasted** rain, daily during extended rain events, after rain events, weekly during the rainy season, and at two-week intervals during the non-rainy season
- Replace missing rock, bags, bales, etc. Replace bags or bales that have degraded or have become damaged
- If the check dam is used as a sediment capture device, sediment that accumulates in the BMP must be periodically removed in order to maintain BMP effectiveness Sediment should be removed when the sediment

accumulation reaches one-third of the barrier height. Sediment removed during maintenance may be incorporated into earthwork on the site or disposed at an appropriate location

- If significant erosion occurs between dams, install a protective riprap liner in that portion of the channel
- Remove check dam and accumulated sediment when check dams are no longer needed

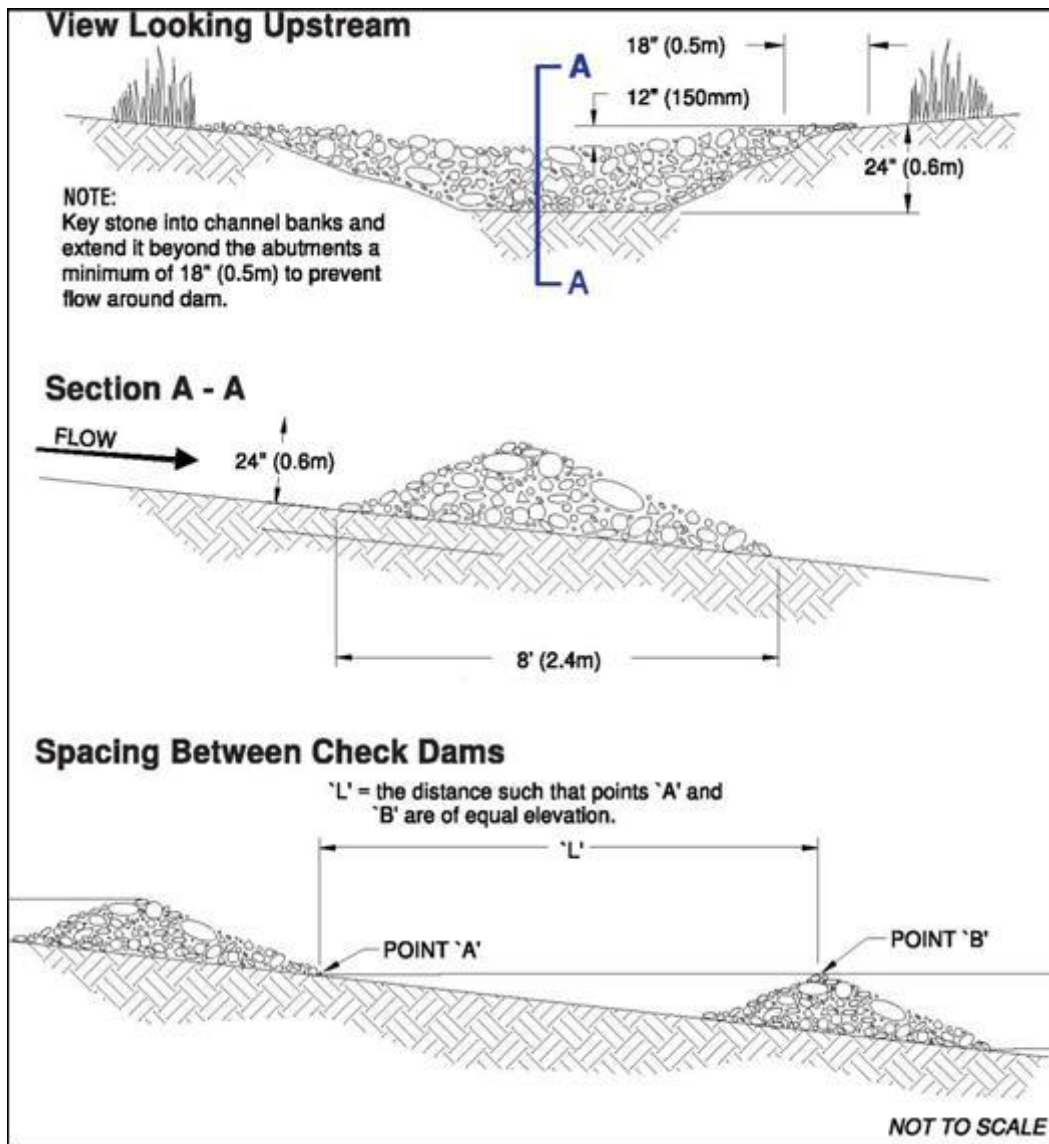

FIGURE EC-14-1 CHECK DAMS

From: Stormwater Management Manual for Western Washington, Washington Department of Ecology, 2001

15. BMP EC-15: Wood Chip, Straw, and Bark mulches.

Purpose. Wood chips, straw, and bark mulches are used in landscape areas as ornamental decoration, soil stabilization, and areas recently seeded. Mulches are used

to protect the soil surface from raindrop and irrigation impact, to create a microenvironment, to increase infiltration, to conserve moisture around tree and shrub plantings, to prevent soil compaction or crusting and to decrease runoff.

Applicability. Bark and wood chip mulches as applicable to any landscape area where trees and shrubs have been planted. Straw mulch is utilized in new seedlings to create a microenvironment, protect the soil surface and improve seed germination.

Planning Criteria. Wood chips can be produced on-site by processing tree trunks, limbs, and branches in a wood chipper. Chips should range in size from ½- to 3-inches in length, ½- to 1-½-inches in width, and ⅓- to ½-inch in thickness. Chips produced from tree trimmings with significant quantities of leaves or small twigs are not effective as mulch. Straw mulches are widely used in revegetation projects. Straw must be anchored to the soil by one or more of the following methods to prevent wind blowing:

- Crimping, rolling, disking, or punching
- Covering with netting or
- Spraying with a chemical or tackifier

The steeper the slope or in wind prone areas, the greater the need for anchoring the straw. Bark requires a large tree source for on site processing or it can be purchased in varying sizes. The larger sizes, greater than 6-inches, withstand wind and are not as likely to move.

Methods and Materials. Wood or bark chips may be processed from any clean, green, soft wood. A permeable landscape cloth should be placed over the soil surface and the chips blown or spread by hand to a uniform thickness, which fully covers the project area. Excess chips can be safely returned to the undisturbed forest floor to supplement existing organic cover. Chips should not be used on decomposed granite slopes over 30%.

Only clean wheat, barley, oat or rice straw should be utilized to prevent the spread of noxious weeds. Straw can be blown on or applied by hand to a uniform depth of approximately 2-inches or approximately 2 tons per acre. The straw must be anchored by an appropriate method immediately after application. Slopes steeper than 3:1 and areas adjacent to streams or drainages should be netted to prevent sliding of material and material entering the watercourse.

Maintenance. Mulched areas must be regularly inspected for damage and remulched as necessary. Inspections and repairs should also be conducted after precipitation or storm events.

Effectiveness. Wood chip and bark mulches deteriorate slower than the wood fiber in hydromulches and, therefore, retain their effectiveness longer. Wood chips and bark are heavier than straw and less subject to removal by wind. Straw mulch is very effective if it is applied, anchored, and maintained properly.

16. BMP EC-16: Plastic Covering.

Purpose. Plastic covering provides immediate, short-term erosion protection to slopes and disturbed areas.

Conditions of Use.

- Plastic covering may be used on disturbed areas that require cover measures for less than 30 days, except as stated below
- Plastic is particularly useful for protecting cut and fill slopes and stockpiles.
Note: The relatively rapid breakdown of most polyethylene sheeting makes it unsuitable for long-term (greater than six months) applications
- Clear plastic sheeting can be used over newly-seeded areas to create a greenhouse effect and encourage grass growth if the hydroseed was installed too late in the season to establish 75% grass cover, or if the wet season started earlier than normal. Clear plastic should not be used for this purpose during the summer months because the resulting high temperatures can kill the grass
- Due to rapid runoff caused by plastic sheeting, this method shall not be used upslope of areas that might be adversely impacted by concentrated runoff. Such areas include steep and/or unstable slopes
- While plastic is inexpensive to purchase, the added cost of installation, maintenance, removal, and disposal make this an expensive material, up to \$1.50-2.00 per square yard
- Whenever plastic is used to protect slopes, water collection measures must be installed at the base of the slope. These measures include plastic-covered berms, channels, and pipes used to convey clean rainwater away from bare soil and disturbed areas. At no time is clean runoff from a plastic covered slope to be mixed with dirty runoff from a project
- Other uses for plastic include:
 1. Temporary ditch liner.
 2. Pond liner in temporary sediment pond.
 3. Liner for bermed temporary fuel storage area if plastic is not reactive to the type of fuel being stored.
 4. Emergency slope protection during heavy rains and
 5. Temporary drainpipe ("elephant trunk") used to direct water.

Design and Installation Specifications.

- Plastic slope cover must be installed as follows:
 1. Run plastic up and down slope, not across slope.
 2. Plastic may be installed perpendicular to a slope if the slope length is less than 10 feet.
 3. Minimum of 8-inch overlap at seams.

4. On long or wide slopes, or slopes subject to wind, all seams should be taped.
 5. Place plastic into a small (12-inch wide by 6-inch deep) slot trench at the top of the slope and backfill with soil to keep water from flowing underneath.
 6. Place sand filled burlap or geotextile bags every 3 to 6 feet along seams and pound a wooden stake through each to hold them in place.
 7. Inspect plastic for rips, tears, and open seams regularly and repair immediately. This prevents high velocity runoff from contacting bare soil that causes extreme erosion.
 8. Sandbags may be lowered into place tied to ropes. However, all sandbags must be staked in place.
- Plastic sheeting shall have a minimum thickness of 0.06 millimeters (2.5 mils)
 - If erosion at the toe of a slope is likely, a gravel berm, riprap, or other suitable protection shall be installed at the toe of the slope in order to reduce the velocity of runoff

Maintenance Standards.

- Torn sheets must be replaced and open seams repaired
- If the plastic begins to deteriorate due to ultraviolet radiation; it must be completely removed and replaced
- When the plastic is no longer needed it shall be completely removed

17. BMP EC-17: Jute & Synthetic Netting and Blankets.

Purpose. Erosion control nets and blankets are intended to prevent erosion and hold seed and mulch in place on steep slopes and in channels so that vegetation can become well established. Netting provides stability to surface disturbances and reduces the soil erosion potential.

Nets (commonly called matting) are strands of material woven into an open, but high-tensile strength net (for example, coconut fiber matting). Blankets are strands of material that are not tightly woven, but instead form a layer of interlocking fibers, typically held together by a biodegradable or photodegradable netting (for example, excelsior or straw blankets). They generally have lower tensile strength than nets, but cover the ground more completely. Coir (coconut fiber) fabric comes as both nets and blankets.

Netting is applicable to any situation that straw or wood chip mulch is utilized. Typical applications include: revegetation of surface disturbances, road cut and fill slopes, ski slopes, mine reclamation sites, etc. Netting can be utilized in both temporary and permanent applications.

Conditions of Use. Erosion control nets and blankets should be used:

- To aid permanent vegetated stabilization of slopes 2H: 1V or greater and with more than 10 feet of vertical relief

- For drainage ditches and swales (highly recommended). The application of appropriate netting or blanket to drainage ditches and swales can protect bare soil from channelized runoff while vegetation is established. Nets and blankets also can capture a great deal of sediment due to their open, porous structure. Synthetic nets and blankets can be used to permanently stabilize channels and may provide a cost-effective, environmentally preferable alternative to riprap. 100% synthetic blankets manufactured for use in ditches may be easily reused as temporary ditch liners

Disadvantages of blankets include:

- Surface preparation required
- On slopes steeper than 2.5:1, blanket installers may need to be roped and harnessed for safety
- [~~They cost at least \$4,000-6,000 per acre installed~~]

Advantages of blankets include:

- Can be installed without mobilizing special equipment
- Can be installed by anyone with minimal training
- Can be installed in stages or phases as the project progresses
- Seed and fertilizer can be hand-placed by the installers as they progress down the slope
- Can be installed in any weather
- There are numerous types of blankets that can be designed with various parameters in mind. Those parameters include: fiber blend, mesh strength, longevity, biodegradability, cost, and availability

Design and Installation Specifications.

- Seed and/or mulch the disturbed areas
- Starting above the mulched and/or seeded area, anchor the top end of the netting by burying it in a trench at least 4 inches deep by 8 inches wide; backfill and compact the excavated material into this trench
- The netting should extend beyond the edge of the mulched or seeded area at least 1 foot on the sides, and 3 feet at the top and bottom. Fasten with a row of wire staples on 1-foot centers
- Roll the netting out, perpendicular with the slope and secure with staples on 3-foot centers. The "U" shaped staples should be 6 inches to 10 inches long, with a 1-inch crown. Longer staples should be used in loose or sandy soils
- Overlap netting at least 1 foot on the sides and secure with staples on 1-foot centers along the overlap
- Overlap the lower end of the uphill strip over the downhill strip at least 1 foot and secure with staples on 1 foot centers

- Continue adding strips of netting until the entire mulched area is covered and secured with staples
- The netting should be cut to fit around protruding rocks or other large objects, and tucked in around smaller rocks or objects preventing "bridging"

Maintenance Standards.

- Good contact with the ground must be maintained, and erosion must not occur beneath the net or blanket
- Any areas of the net or blanket that are damaged or not in close contact with the ground shall be repaired and stapled
- If erosion occurs due to poorly controlled drainage, the problem shall be fixed and the eroded area protected

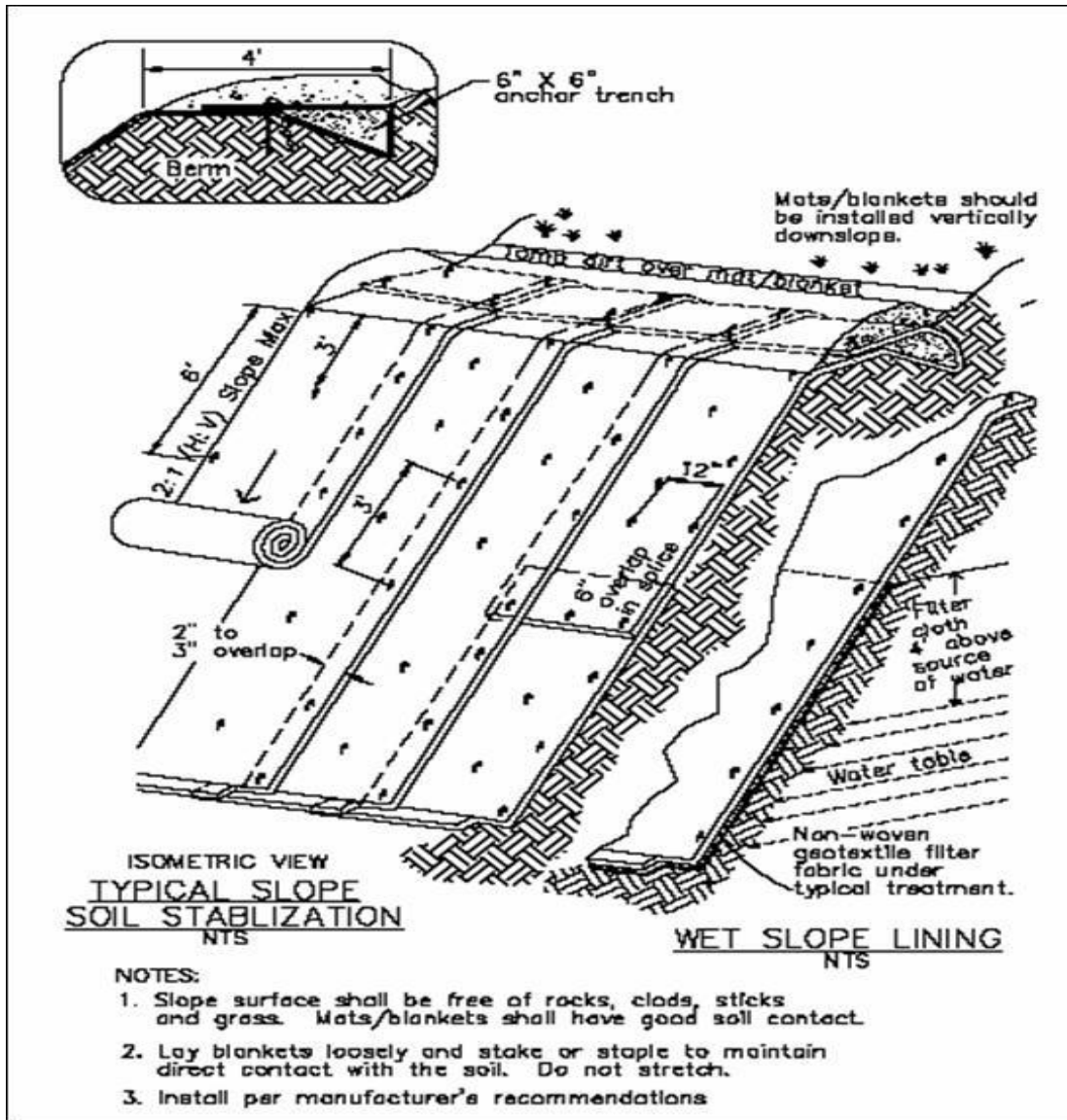

FIGURE EC-17-1 TYPICAL INSTALLATION DETAIL

From: California Stormwater BMP Handbook Construction, California Storm Water Quality Association, 2003

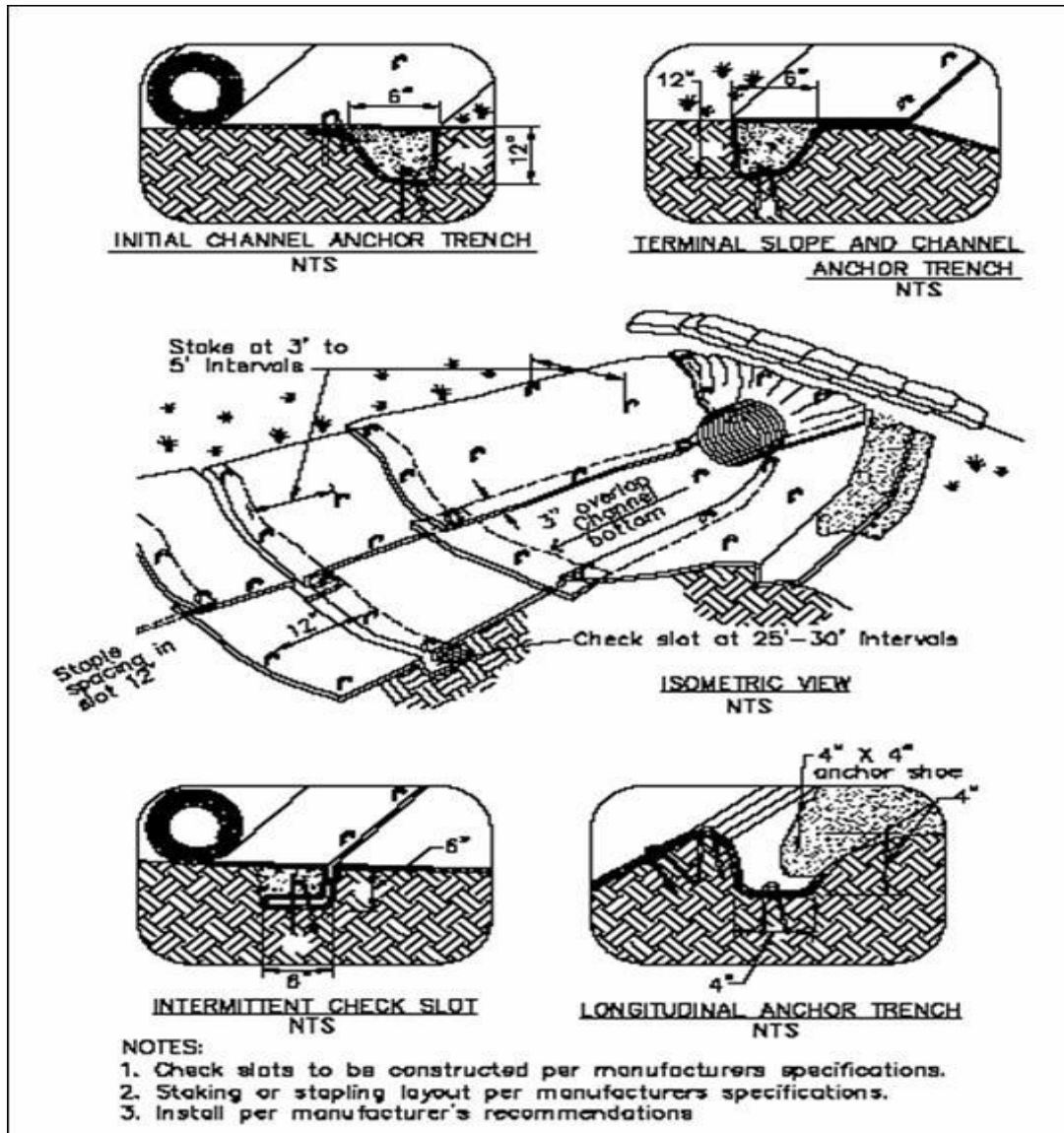

FIGURE EC-17-2 TYPICAL INSTALLATION DETAIL

18. BMP EC-18: Rock riprap.

Purpose. Rock riprap is a layer of loose rock placed over an erodible soil or surface disturbance to protect the soil surface, provide for slope stabilization on steep slopes and reduce soil erosion within a project area.

Conditions of Use.

- Rock riprap is primarily utilized in drainage stabilization projects such as channel and ditch linings and energy dissipaters
- Rock riprap is used on steep, difficult slopes where vegetation has not been successful

- Seed, shrubs, and trees have been incorporated with rock riprap by interplanting
- A source of rock riprap of the appropriate size and the associated transportation cost are the primary planning criteria
- Depending upon the application, rock riprap can be utilized with revegetation efforts but the establishment of permanent vegetation is preferred for long-term stability and maintenance
- Rock riprap applied to active drainage-ways or channels usually requires an underlining of matting or fabric to prevent erosion
- Rock riprapping is an effective means of reducing soil erosion in channels and drainage-ways

Design and Installation Specifications.

- The rock riprap should be sound, dense, and durable rock with a specific gravity of not less than 2-½ and greater than 12 inches in diameter
- Seeding should occur prior to rock placement
- If to be used within an active drainage channel, a synthetic mat or fabric should be installed prior to rock placement
- Depending on the specifics of the site, rock riprap can be placed by hand or by equipment
- Existing trees and vegetation should be protected and rock riprap placed by hand in these areas
- Rocks should be securely bedded and homogenous in the layering
- Depth of application depends upon the size of the drainage-way, slope degree and length and the other specifics of the site

Maintenance Standards.

- Inspect BMP [~~prior to forecast~~] **before forecasted** rain, daily during extended rain events, after rain events, weekly during the rainy season, and at two-week intervals during the non-rainy season
- Inspect for displacement of the riprap and damage to the underlying fabric. Repair fabric and replace riprap that has washed away. If riprap continues to wash away, consider using larger material
- Inspect for scour beneath the riprap and repair immediately
- Remove temporary devices as soon as the surrounding drainage area has been stabilized or at the completion of construction

19. BMP EC-19: Polyacrylamide (PAM) for Soil Erosion Protection.

Purpose. Polyacrylamide (PAM) is used on construction sites to prevent soil erosion. Applying PAM to bare soil in advance of a rain event significantly reduces erosion and controls sediment in two ways. First, PAM increases the soil's available

pore volume, thus increasing infiltration through flocculation and reducing the quantity of stormwater runoff. Second, it increases flocculation of suspended particles and aids in their deposition, thus reducing stormwater runoff turbidity and improving water quality.

Conditions of Use.

- PAM is suitable for use on disturbed soil area that discharge to a sediment trap or sediment basin
- PAM is typically used in conjunction with other BMPs to increase their performance
- PAM can be applied to the following areas:
 - ✓ Rough graded soils that will be inactive for a period of time
 - ✓ Final graded soils before application of final stabilization (e.g., paving, planting, mulching)
 - ✓ Haul roads prior to placement of crushed rock surfacing
 - ✓ Compacted soil road base
 - ✓ Construction staging, materials storage, and layout areas
 - ✓ Soil stockpiles
 - ✓ Areas that will be mulched

Limitations.

- PAM must not be directly applied to water or allowed to enter a water body
- Do not use PAM on a slope that flows into a water body without passing through a sediment trap or sediment basin
- PAM will work when applied to saturated soil but is not as effective as applications to dry or damp soil
- On all sites, the use of silt fence shall be maximized to limit the discharges of sediment from the site
- All areas not being actively worked shall be covered and protected from rainfall. PAM shall not be the only cover BMP used
- Some PAMs are more toxic and carcinogenic than others. Only the most environmentally safe PAM products should be used
- PAM designated for erosion and sediment control should be "water soluble" or "linear" or "non-cross linked"
- PAM, combined with water, is very slippery and can be a safety hazard. Care must be taken to prevent spills of PAM powder onto paved surfaces. During an application of PAM, prevent over-spray from reaching pavement, as pavement will become slippery. If PAM powder gets on skin or clothing,

wipe it off with a rough towel rather than washing with water-this only makes cleanup messier and take longer

- A sampling and analysis plan must be incorporated into the SWPPP as PAM may be considered to be a source of non-visible pollutants

Design and Installation Specifications.

- PAM may be applied in dissolved form with water, or it may be applied in dry, granular or powdered form. The preferred application method is the dissolved form. PAM is to be applied at a maximum rate of ½ pound PAM per 1000 gallons water per 1 acre of bare soil. Higher concentrations of PAM do not provide any additional effectiveness
- Pre-measure the area where PAM is to be applied and calculate the amount of product and water necessary to provide coverage at the specified application rate (½ pound PAM/1000 gallons/acre)
- PAM has infinite solubility in water, but dissolves very slowly. Dissolve pre-measured dry granular PAM with a known quantity of clean water in a bucket several hours or overnight. Mechanical mixing will help dissolve the PAM. Always add PAM to water - not water to PAM
- Pre-fill the water truck about 1/8 full with water. The water does not have to be potable, but it must have relatively low turbidity - in the range of 20 NTU or less.
- Add PAM/water mixture to the truck
- Completely fill the water truck to specified volume
- Spray PAM/water mixture onto dry soil until the soil surface is uniformly and completely wetted
- PAM may be applied as a powder at the rate of 5 lbs. per acre. This must be applied on a day that is dry. For areas less than 5-10 acres, a hand-held "organ grinder" fertilizer spreader set to the smallest setting will work. Tractor-mounted spreaders will work for larger areas

Maintenance Standards. The following shall be used for application of PAM:

- PAM may be reapplied on actively worked areas after a 48-hour period
- Proper application and re-application plans are necessary to ensure total effectiveness of PAM usage
- Reapplication is not required unless PAM treated soil is disturbed or unless turbidity levels show the need for an additional application. If PAM treated soil is left undisturbed a reapplication may be necessary after two months. More PAM applications may be required for steep slopes, silty and clayey soils (USDA Classification Type "C" and "D" soils), long grades, and high precipitation areas. When PAM is applied first to bare soil and then covered with straw, a reapplication may not be necessary for several months

20. BMP EC-20: Topsoiling.

Purpose. To provide a suitable growth medium for final site stabilization with vegetation. While not a permanent cover practice ~~[in itself]~~, topsoiling is an integral component of providing permanent cover in those areas where there is an unsuitable soil surface for plant growth. Native soils and disturbed soils that have been organically amended not only retain much more stormwater, but they also serve as effective biofilters for urban pollutants and, by supporting more vigorous plant growth, reduce the water, fertilizer and pesticides needed to support installed landscapes. Topsoil does not include any subsoils but only the material from the top several inches including organic debris.

Conditions of Use.

- Native soils should be left undisturbed to the maximum extent practicable. Native soils disturbed during clearing and grading should be restored, to the maximum extent practicable, to a condition where moisture-holding capacity is equal to or better than the original site conditions. This criterion can be met by using on-site native topsoil, incorporating amendments into on-site soil, or importing blended topsoil
- Topsoiling is a required procedure when establishing vegetation on shallow soils, and soils of critically low pH (high acid) levels
- Stripping of existing, properly functioning soil system and vegetation for the purpose of topsoiling during construction is not acceptable. If an existing soil system is functioning properly it shall be preserved in its undisturbed and uncompacted condition
- Depending on where the topsoil comes from, or what vegetation was on site before disturbance, invasive plant seeds may be included and could cause problems for establishing native plants, landscaped areas, or grasses
- Topsoil from the site will contain mycorrhizal bacteria that are necessary for healthy root growth and nutrient transfer. These native mycorrhiza are acclimated to the site and will provide optimum conditions for establishing grasses. Commercially available mycorrhiza products should be used when topsoil is brought in from off-site

Design and Installation Specifications. If topsoiling is to be done, the following items should be considered:

- Maximize the depth of the topsoil wherever possible to provide the maximum possible infiltration capacity and beneficial growth medium. Topsoil depth shall be at least 8 inches with a minimum organic content of 10% dry weight and pH between 6.0 and 8.0 or matching the pH of the undisturbed soil. This can be accomplished either by returning native topsoil to the site and/or incorporating organic amendments. Organic amendments should be incorporated to a minimum 8-inch depth except where tree roots or other natural features limit the depth of incorporation. Subsoils below the 12-inch depth should be scarified at least 2 inches to avoid stratified layers, where feasible. The decision to either layer topsoil over a subgrade or incorporate

topsoil into the underlying layer may vary depending on the planting specified

- If blended topsoil is imported, fines should be limited to 25% passing through a 200 sieve
- The final composition and construction of the soil system will result in a natural selection of certain plant species over time
- Locate the topsoil stockpile so that it meets specifications and does not interfere with work on the site. It may be possible to locate more than one pile in proximity to areas where topsoil will be used
- Allow sufficient time in scheduling for topsoil to be spread prior to seeding, sodding, or planting
- Care must be taken not to apply to subsoil if the two soils have contrasting textures. Sandy topsoil over clayey subsoil is a particularly poor combination, as water creeps along the junction between the soil layers and causes the topsoil to slough
- If topsoil and subsoil are not properly bonded, water will not infiltrate the soil profile evenly and it will be difficult to establish vegetation. The best method to prevent a lack of bonding is to actually work the topsoil into the layer below for a depth of at least 6 inches
- Ripping or re-structuring the subgrade may also provide additional benefits regarding the overall infiltration and interflow dynamics of the soil system
- Field exploration of the site shall be made to determine if there is surface soil of sufficient quantity and quality to justify stripping
- Topsoil shall be friable and loamy (loam, sandy loam, silt loam, sandy clay loam, clay loam). Areas of natural ground water recharge should be avoided
- Stripping shall be confined to the immediate construction area. A 4- to 6- inch stripping depth is common, but depth may vary depending on the particular soil. All surface runoff control structures shall be in place prior to stripping

Stockpiling of topsoil shall occur in the following manner:

- Side slopes of the stockpile shall not exceed 2:1
- An interceptor dike with gravel outlet and silt fence shall surround all topsoil stockpiles during the rainy season or if the stockpile will remain in place for a longer period of time than active construction grading
- Erosion control seeding or covering with clear plastic or other mulching materials of stockpiles shall be completed within 7 days of the formation of the stockpile. Native topsoil stockpiles shall not be covered with plastic
- Topsoil shall not be placed while in a frozen or muddy condition, when the subgrade is excessively wet, or when conditions exist that may otherwise be detrimental to proper grading or proposed sodding or seeding

- Previously established grades on the areas to be topsoiled shall be maintained according to the approved plan
- When native topsoil is to be stockpiled and reused the following should apply to ensure that the mycorrhizal bacterial, earthworms, and other beneficial organisms will not be destroyed:
 - 1 Topsoil is to be re-installed within 4 to 6 weeks.
 - 2 Topsoil is not to become saturated with water.
 - 3 Plastic cover is not allowed.

Maintenance Standards.

- Inspect stockpiles regularly, especially after large storm events. Stabilize any areas that have eroded

21. BMP EC-21: Seeding Practices.

Purpose. Seeding practices include a variety of techniques, which result in the sowing, or planting of seeds. Common practices include broadcast seeding (hand or mechanical), drill seeding, aerial seeding, and hydroseeding. The primary purpose of seeding a site is for soil stabilization through the establishment of a vegetative cover. Related objectives include: to reduce raindrop impacts and surface water flow, to reduce erosion from wind and water and to enhance aesthetics and the natural environment.

Conditions of Use.

- Seeding practices are applicable to any surface disturbance site requiring revegetation or reclamation
- Slopes must be mechanically stabilized prior to seeding, as vegetation alone will not stabilize a slope
- Drilling seeding is typically limited to slopes of 3:1 or flatter, but it is the most successful practice
- Hydroseeding is most effective in steep slope situations, which have little or no access (e.g., road cut or fill slopes, mine waste dumps, etc.)
- Broadcast seeding is less expensive but requires approximately twice the amount of seed over drill seeding
- Aerial seedings are typically applied in large areas with no access, such as forest or rangeland fires

{■

■]

Planning Criteria.

- The establishment of vegetation is the most efficient and cost effective form of erosion control and soil stabilization. Once established vegetation absorbs raindrop impact and prevents the mobilization of soil particles. Vegetation

prevents erosion while other treatments such as filter fabric, sediment basins or filter strips only treat the sediment mobilization process

- Seeding practices should be selected based upon the specifics of the site and the expertise of a qualified professional should be consulted
- Typically economics, site topography and/or access are controlling factors in the selection process. Seeding practices should also be tailored to the plant material seed being applied (i.e. grasses, forbs, shrubs)
- Tree species are typically planted from container stock after establishment of a grass/forb/shrub cover
- Seeding practices are usually incorporated within a combined structural and vegetative approach to soil stabilization
- Vegetation alone will not stabilize a slope. Other nonvegetative techniques are also utilized to enhance the success of a seeding such as mulches, netting, matting, and chemical tacifiers
- Irrigation will assist in achieving a good seed/soil contact and is critical to plant establishment on dry sites. Over watering will cause washing and runoff, thus potentially transporting seed down gradient

Design and Installation Specifications. Vegetation or reclamation specialists should be consulted regarding mulch application rates, plant species selection, seeding rates, etc., to ensure a successful project.

- Broadcast seeding (hand or mechanical): Broadcast seeding can be accomplished by hand held seeders or a mechanically driven seeder typically mounted on a tractor or ATV vehicle. The seed mix is placed in a hopper, adjustments are made for the size of the seed and rate of application, and the seeder is operated by a hand crank or motor while walking or driving over the areas to be seeded. Broadcast seeding typically require twice the amount of seed to cover the same given area as a drill seeder due to wind drift, wildlife consumption, and lack of good soil to seed contact
- Drill seeding: Drill seeding requires the use of a Range drill or equivalent depending on the condition of the site. Drill seeders are pulled behind a tractor or bulldozer and actually place the seed to a pre-determined depth. The seed is then covered by the drill mechanism or a chain drag is utilized to cover the seed behind the drill. Drill seeding provides the best seed to soil contact and correspondingly the highest success rate
- Aerial seeding: Aerial seeding is conducted by helicopter or fixed wing aircraft and can cover larger areas of inaccessible terrain. It is the most efficient method for large disturbance areas such as forest or rangeland fires. Germination success is usually low given wind drift, soil conditions, and poor seed to soil contact, but application timing can greatly improve success. If seeding can occur shortly after a wild land fire and before a soil crust is formed, success is greatly improved

- Hydroseeding: The wood fiber and water mixture are well agitated in a large tank and then blown through a hose and nozzle by compressed air. The apparatus is typically truck or trailer mounted and has sufficient capacity to complete several acres at a time. Mulch application rates and/or seeding rates depend upon the site specifics of the project area and the project goals. Typically irrigation is necessary to successfully establish a vegetative cover with hydroseeding

Maintenance.

- Seeded areas require regular inspection and potentially reapplication if necessary
- The treatment areas should be protected from foot or vehicle traffic until vegetation is well established which may require fencing, barriers, and signing

22. BMP EC-22: Sodding.

Purpose. The purpose of sodding is to establish permanent turf for immediate erosion protection and to stabilize drainage ways where concentrated overland flow will occur.

Conditions of Use. Sodding may be used in the following areas:

- Disturbed areas that require short-term or long-term cover
- Disturbed areas that require immediate vegetative cover
- All waterways that require vegetative lining. Waterways may also be seeded rather than sodded, and protected with a net or blanket

Design and Installation Specifications. Sod shall be free of weeds, of uniform thickness (approximately 1-inch thick), and shall have a dense root mat for mechanical strength. The following steps are recommended for sod installation:

- Shape and smooth the surface to final grade in accordance with the approved grading plan. The swale needs to be over excavated 4 to 6 inches below design elevation to allow room for placing soil amendment and sod
- Amend 4 inches (minimum) of compost into the top 8 inches of the soil if the organic content of the soil is less than ten percent or the permeability is less than 0.6 inches per hour. Compost used should meet Ecology publication 94-038 specifications for Grade "A" quality compost
- Fertilize according to the supplier's recommendations
- Work lime and fertilizer 1 to 2 inches into the soil, and smooth the surface
- Lay strips of sod beginning at the lowest area to be sodded and perpendicular to the direction of water flow. Wedge strips securely into place. Square the ends of each strip to provide for a close, tight fit. Stagger joints at least 12 inches. Staple on slopes steeper than 3H: 1V. Staple the upstream edge of each sod strip
- Roll the sodded area and irrigate

- When sodding is carried out in alternating strips or other patterns, seed the areas between the sods immediately after sodding

Maintenance Standards. If the grass is unhealthy, the cause shall be determined and appropriate action taken to reestablish a healthy groundcover. If it is impossible to establish a healthy groundcover due to frequent saturation, instability, or some other cause, the sod shall be removed, the area seeded with an appropriate mix, and protected with a net or blanket.

B. Sediment Control BMPs.

1. BMP SC-1: Stabilized Construction Entrance.

Purpose. Construction entrances are stabilized to reduce the amount of sediment transported onto paved roads by vehicles or equipment by constructing a stabilized pad of quarry spalls at entrances to construction sites.

Conditions of Use. Construction entrances shall be stabilized wherever traffic will be leaving a construction site and traveling on paved roads or other paved areas within 1,000 feet of the site. On large commercial, highway, and road projects, the designer should include enough extra materials in the contract to allow for additional stabilized entrances not shown in the initial Construction SWPPP. It is difficult to determine exactly where access to these projects will take place; additional materials will enable the contractor to install them where needed.

Design and Installation Specifications.

- A separation geotextile shall be placed under the spalls to prevent fine sediment from pumping up into the rock pad. The geotextile shall meet the following standards:
 - Grab Tensile Strength (ASTM D4751) 200 psi min
 - Grab Tensile Elongation (ASTM D4632) 30% max
 - Mullen Burst Strength (ASTM D3786-80a) 400 psi min
 - AOS (ASTM D4751) 20-45 (U.S. standard sieve size)
- Consider early installation of the first lift of asphalt in areas that will be paved; this can be used as a stabilized entrance. Also consider the installation of excess concrete as a stabilized entrance. During large concrete pours, excess concrete is often available for this purpose
- ~~■ Hog fuel (wood-based mulch) may be substituted for or combined with quarry spalls in areas that will not be used for permanent roads. Hog fuel is generally less effective at stabilizing construction entrances and should be used only at sites where the amount of traffic is very limited. Hog fuel is not recommended for entrance stabilization in urban areas. The effectiveness of hog fuel is highly variable and it generally requires more maintenance than quarry spalls. The inspector may at any time require the use of quarry spalls if the hog fuel is not preventing sediment from being tracked onto pavement or if the hog fuel is being carried onto pavement. Hog fuel is prohibited in~~

~~permanent roadbeds because organics in the subgrade soils cause degradation of the subgrade support over time]~~

- Fencing (see BMP EC-4) shall be installed as necessary to restrict traffic to the construction entrance
- Whenever possible, the entrance shall be constructed on a firm, compacted subgrade. This can substantially increase the effectiveness of the pad and reduce the need for maintenance

Maintenance Standards.

- Quarry spalls [~~(or hog fuel) shall~~] **must** be added if the pad is no longer in accordance with the specifications
- If the entrance is not preventing sediment from being tracked onto pavement, then alternative measures to keep the streets free of sediment shall be used. This may include street sweeping, an increase in the dimensions of the entrance, or the installation of a wheel wash
- Any sediment that is tracked onto pavement shall be removed by shoveling or street sweeping. The sediment collected by sweeping shall be removed or stabilized on site. The pavement shall not be cleaned by washing down the street, except when sweeping is ineffective and there is a threat to public safety. If it is necessary to wash the streets, the construction of a small sump shall be considered. The sediment would then be washed into the sump where it can be controlled
- Any quarry spalls that are loosened from the pad, which end up on the roadway shall be removed immediately
- If vehicles are entering or exiting the site at points other than the construction entrance(s), fencing (see BMP EC-4) shall be installed to control traffic
- Upon project completion and site stabilization, all construction accesses intended as permanent access for maintenance shall be permanently stabilized

Inspection and Maintenance.

- Inspect and verify that activity-based BMPs are in place prior to the commencement of associated activities. While activities associated with the BMPs are under way, inspect weekly **or, if deemed necessary by the City, even more frequently,** during the rainy season and at two-week intervals in the non-rainy season to verify continued BMP implementation
- Inspect local roads adjacent to the site daily. Sweep or vacuum to remove visible accumulated sediment
- Remove quarry spalls, separate and dispose of sediment if construction entrance/exit is clogged with sediment
- Keep all temporary roadway ditches clear
- Check for damage and repair as needed

- Remove all sediment deposited on paved roadways within 24 hours
- Remove stabilized construction entrance at completion of construction

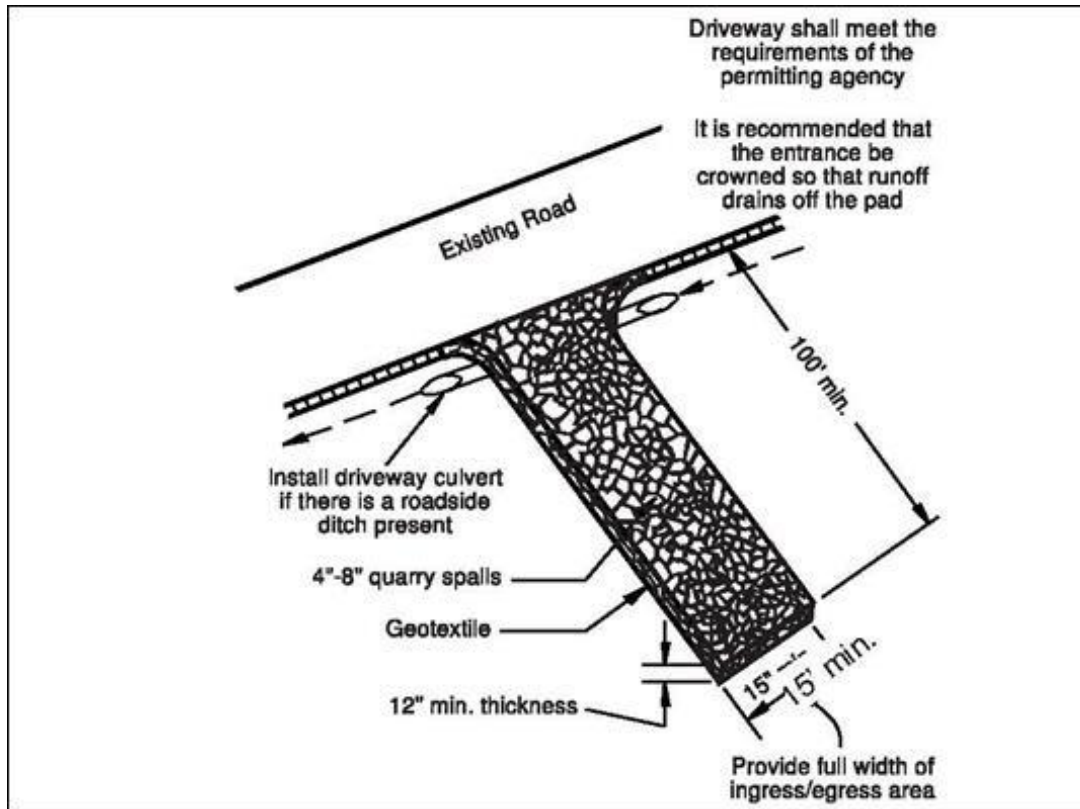

FIGURE SC-1-1 STABILIZED CONSTRUCTION ENTRANCE

From: Stormwater Management Manual for Western Washington, Washington Department of Ecology, 2001

2. BMP SC-2: Wheel Wash.

Purpose. Wheel washes reduce the amount of sediment transported onto paved roads by motor vehicles.

Conditions of Use. When a stabilized construction entrance (see SC-1) is not preventing sediment from being tracked onto pavement.

- Wheel washing is generally an effective BMP when installed with careful attention to topography. For example, a wheel wash can be detrimental if installed at the top of a slope abutting a right-of-way where the water from the dripping truck can run unimpeded into the street
- Pressure washing combined with an adequately sized and surfaced pad with direct drainage to a large 10-foot x 10-foot sump can be very effective

Design and Installation Specifications.

- Suggested details are shown in Figure SC-2-1
- A minimum of 6 inches of asphalt treated base (ATB) over crushed base material or 8 inches over a good subgrade is recommended to pave the wheel

wash. Use a low clearance truck to test the wheel wash before paving. Either a belly dump or lowboy will work well to test clearance

- Keep the water level from 12 to 14 inches deep to avoid damage to truck hubs and filling the truck tongues with water
- Midpoint spray nozzles are only needed in extremely muddy conditions
- Wheel wash systems should be designed with a small grade change, 6 to 12 inches for a 10-foot-wide pond, to allow sediment to flow to the low side of pond to help prevent re-suspension of sediment
- A drainpipe with a 2- to 3-foot riser should be installed on the low side of the pond to allow for easy cleaning and refilling
- Polymers may be used to promote coagulation and flocculation in a closed-loop system. Polyacrylamide (PAM) added to the wheel wash water at a rate of 0.25 - 0.5 pounds per 1,000 gallons of water increases effectiveness and reduces cleanup time. If PAM is already being used for dust or erosion control and is being applied by a water truck, the same truck can be used to change the wash water

Maintenance Standards.

- The wheel wash should start out the day with fresh water
- The wash water should be changed a minimum of once per day. On large earthwork jobs where more than 10-20 trucks per hour are expected, the wash water will need to be changed more often
- Wheel wash or tire bath wastewater shall be discharged to a separate on-site treatment system, such as closed-loop recirculation or land application, or to the sanitary sewer with proper approval

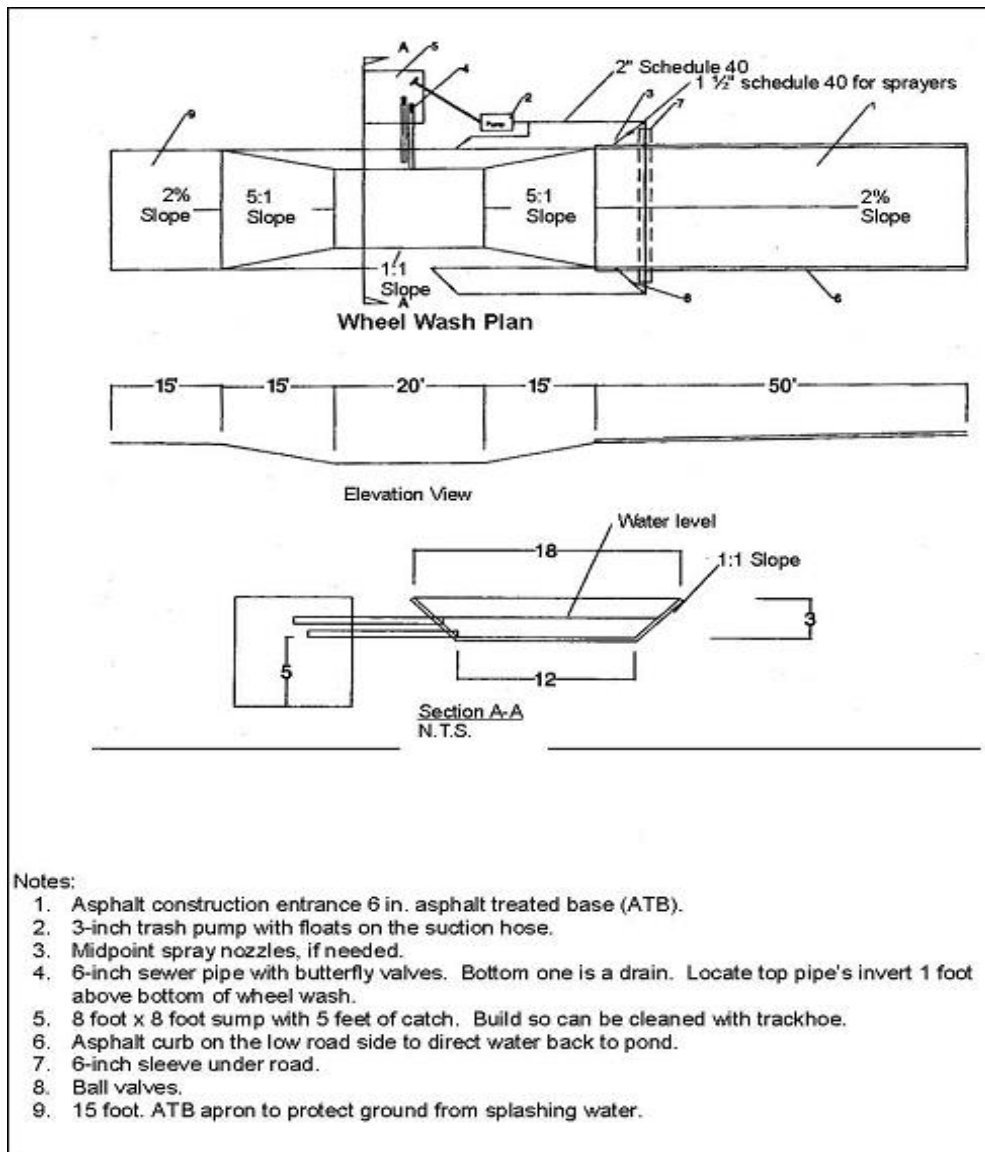

FIGURE SC-2-1 WHEEL WASH

From: Stormwater Management Manual for Western Washington, Washington Department of Ecology, 2001

3. BMP SC-3: Straw Bale Barrier.

Purpose. To decrease the velocity of sheet flows and intercept and detain small amounts of sediment from disturbed areas of limited extent, preventing sediment from leaving the site. See Figure SC-3-1 for details on straw bale barriers.

Conditions of Use.

- Below disturbed areas subject to sheet and rill erosion
- Straw bales are among the most used and least effective BMPs. The best use of a straw bale is hand spread on the site

- Where the size of the drainage area is no greater than 1/4 acre per 100 feet of barrier length; the maximum slope length behind the barrier is 100 feet; and the maximum slope gradient behind the barrier is 2:1
- Where effectiveness is required for less than three months
- Under no circumstances should straw bale barriers be constructed in streams, channels, or ditches
- Straw bale barriers should not be used where rock or hard surfaces prevent the full and uniform anchoring of the barrier

Design and Installation Specifications.

- Bales shall be placed in a single row, lengthwise on the contour, with ends of adjacent bales tightly abutting one another
- All bales shall be either wire-bound or string-tied. Straw bales shall be installed so that bindings are oriented around the sides rather than along the tops and bottoms of the bales in order to prevent deterioration of the bindings
- The barrier shall be entrenched and backfilled. A trench shall be excavated the width of a bale and the length of the proposed barrier to a minimum depth of 4 inches. The trench must be deep enough to remove all grass and other material that might allow underflow. After the bales are staked and chinked (filled by wedging), the excavated soil shall be backfilled against the barrier. Backfill soil shall conform to the ground level on the downhill side and shall be built up to 4 inches against the uphill side of the barrier
- Each bale shall be securely anchored by at least two stakes or re-bars driven through the bale. The first stake in each bale shall be driven toward the previously laid bale to force the bales together. Stakes or re-bars shall be driven deep enough into the ground to securely anchor the bales. Stakes should not extend above the bales but instead should be driven in flush with the top of the bale for safety reasons
- The gaps between the bales shall be chinked (filled by wedging) with straw to prevent water from escaping between the bales. Loose straw scattered over the area immediately uphill from a straw bale barrier tends to increase barrier efficiency. Wedging must be done carefully in order not to separate the bales

Maintenance Standards.

- Straw bale barriers shall be inspected immediately after each runoff producing rainfall and at least daily during prolonged rainfall
- Close attention shall be paid to the repair of damaged bales, end runs, and undercutting beneath bales
- Necessary repairs to barriers or replacement of bales shall be accomplished promptly

- Sediment deposits should be removed after each runoff-producing storm event. They must be removed when the level of deposition reaches approximately one-half the height of the barrier
- Any sediment deposits remaining in place after the straw bale barrier is no longer required shall be dressed to conform to the existing grade, prepared and seeded
- Straw bales used as a temporary straw bale barrier shall be removed after project completion and stabilization to prevent sprouting of unwanted vegetation

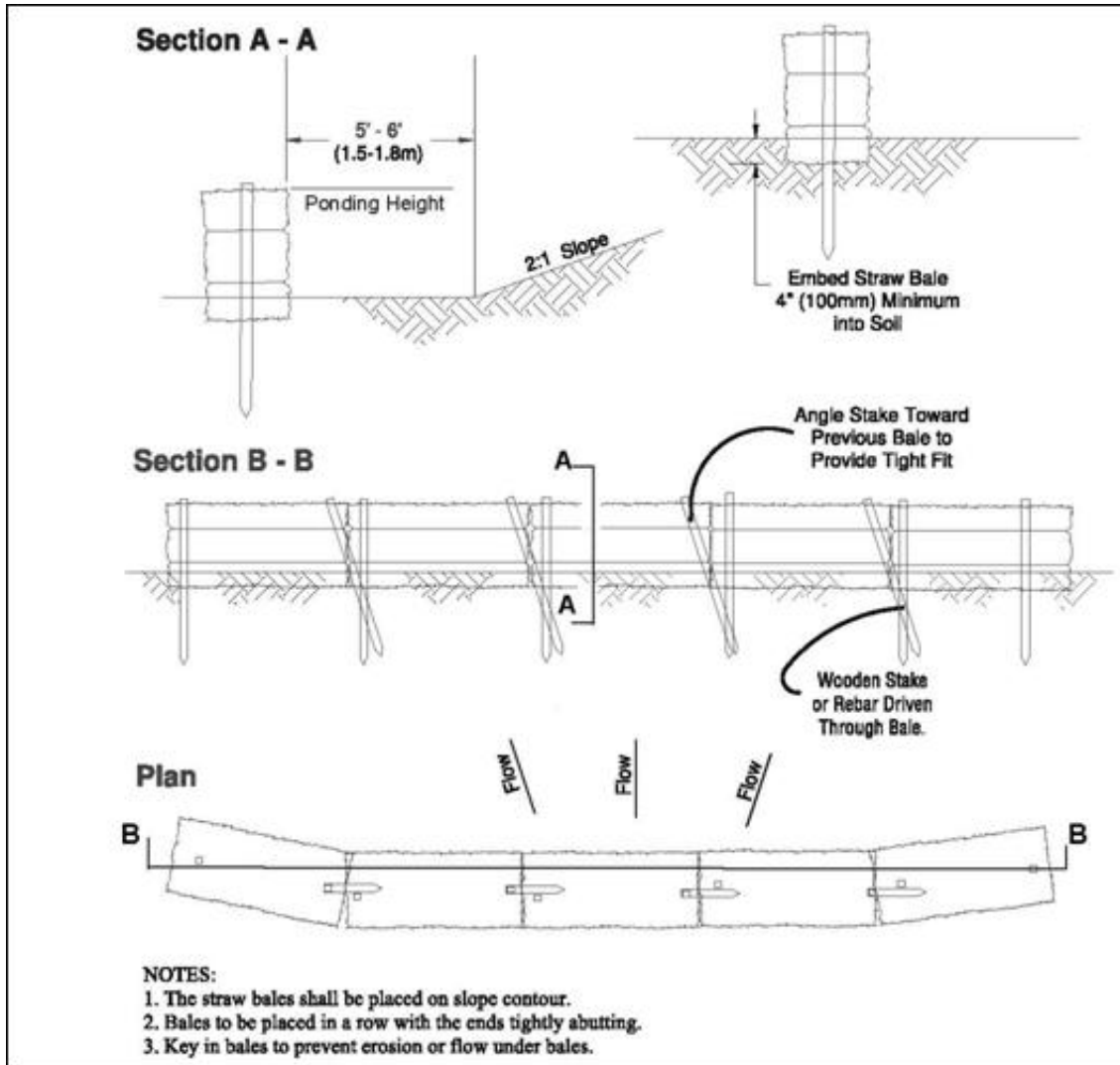

FIGURE SC-3-1 STRAW BALE BARRIER

From: Stormwater Management Manual for Western Washington, Washington Department of Ecology, 2001

4. BMP SC-4: Storm Drain Inlet Protection.

Purpose. To prevent coarse sediment from entering drainage systems prior to permanent stabilization of the disturbed area.

Conditions of Use.

- Where storm drain inlets are to be made operational before permanent stabilization of the disturbed drainage area
- Protection should be provided for all storm drain inlets down slope and within 500 feet of a disturbed or construction area, unless the runoff that enters the catch basin will be conveyed to a sediment pond or trap
- Inlet protection may be used anywhere to protect the drainage system. It is likely that the drainage system will still require cleaning
- All of the methods for storm drain inlet protection are prone to plugging and require a high frequency of maintenance
- Drainage areas should be limited to 1 acre or less
- Emergency overflows may be required where stormwater ponding would cause a hazard. If an emergency overflow is provided, additional end-of-pipe treatment may be required

Design and Installation Specifications. Excavated Drop Inlet Protection - An excavated impoundment around the storm drain. Sediment settles out of the stormwater prior to entering the storm drain.

- Depth 1-2 ft as measured from the crest of the inlet structure
- Side Slopes of excavation no steeper than 2:1
- Minimum volume of excavation 35 cubic yards
- Shape basin to fit site with longest dimension oriented toward the longest inflow area
- Install provisions for draining to prevent standing water problems
- Clear the area of all debris
- Grade the approach to the inlet uniformly
- Drill weep holes into the side of the inlet
- Protect weep holes with screen wire and washed aggregate
- Seal weep holes when removing structure and stabilizing area
- It may be necessary to build a temporary dike to the down slope side of the structure to prevent bypass flow

Block and Gravel Filter - A barrier formed around the storm drain inlet with standard concrete blocks and gravel.

- Height 1 to 2 feet above inlet
- Recess the first row 2 inches into the ground for stability
- Support subsequent courses by placing a 2 × 4 through the block opening
- Do not use mortar

- Lay some blocks in the bottom row on their side for dewatering the pool
- Place hardware cloth or comparable wire mesh with ½-inch openings over all block openings
- Place gravel just below the top of blocks on slopes of 2:1 or flatter
- An alternative design is a gravel donut
- Inlet slope of 3:1
- Outlet slope of 2:1
- 1-foot wide level stone area between the structure and the inlet
- Inlet slope use stones 3 inches in diameter or larger
- Outlet slope use gravel ½- to ¾-inch at a minimum thickness of 1-foot

Gravel and Wire Mesh Filter - A gravel barrier placed over the top of the inlet. This structure does not provide an overflow.

- Hardware cloth or comparable wire mesh with ½-inch openings
- Coarse aggregate
- Height 1-foot or more, 18 inches wider than inlet on all sides
- Place wire mesh over the drop inlet so that the wire extends a minimum of 1-foot beyond each side of the inlet structure
- If more than one strip of mesh is necessary, overlap the strips
- Place coarse aggregate over the wire mesh
- The depth of the gravel should be at least 12 inches over the entire inlet opening and extend at least 18 inches on all sides

Catch basin Filters - Inserts should be designed by the manufacturer for use at construction sites. The limited sediment storage capacity increases the amount of inspection and maintenance required, which may be daily for heavy sediment loads. The maintenance requirements can be reduced by combining a catch basin filter with another type of inlet protection. This type of inlet protection provides flow bypass without overflow and therefore may be a better method for inlets located along active rights-of-way.

- 5 cubic feet of storage
- Dewatering provisions
- High-flow bypass that will not clog under normal use at a construction site
- The catch basin filter is inserted in the catch basin just below the grating

Curb Inlet Protection with Wooden Weir - Barrier formed around a curb inlet with a wooden frame and gravel.

- Wire mesh with ½-inch openings
- Extra strength filter cloth

- Construct a frame
- Attach the wire and filter fabric to the frame
- Pile coarse washed aggregate against wire/fabric
- Place weight on frame anchors

Block and Gravel Curb Inlet Protection - Barrier formed around an inlet with concrete blocks and gravel.

- Wire mesh with ½-inch openings
- Place two concrete blocks on their sides abutting the curb at either side of the inlet opening. These are spacer blocks
- Place a 2 x 4 stud through the outer holes of each spacer block to align the front blocks
- Place blocks on their sides across the front of the inlet and abutting the spacer blocks
- Place wire mesh over the outside vertical face
- Pile coarse aggregate against the wire to the top of the barrier

Curb and Gutter Sediment Barrier - Sandbag or rock berm (riprap and aggregate) 3 feet high and 3 feet wide in a horseshoe shape.

- Construct a horseshoe shaped berm, faced with coarse aggregate if using riprap, 3 feet high and 3 feet wide, at least 2 feet from the inlet
- Construct a horseshoe shaped sedimentation trap on the outside of the berm sized to sediment trap standards for protecting a culvert inlet

Maintenance Standards.

- Catch basin filters should be inspected frequently, especially after storm events. If the insert becomes clogged, it should be cleaned or replaced
- For systems using stone filters: If the stone filter becomes clogged with sediment, the stones must be pulled away from the inlet and cleaned or replaced. Since cleaning of gravel at a construction site may be difficult, an alternative approach would be to use the clogged stone as fill and put fresh stone around the inlet
- Do not wash sediment into storm drains while cleaning. Spread all excavated material evenly over the surrounding land area or stockpile and stabilize as appropriate

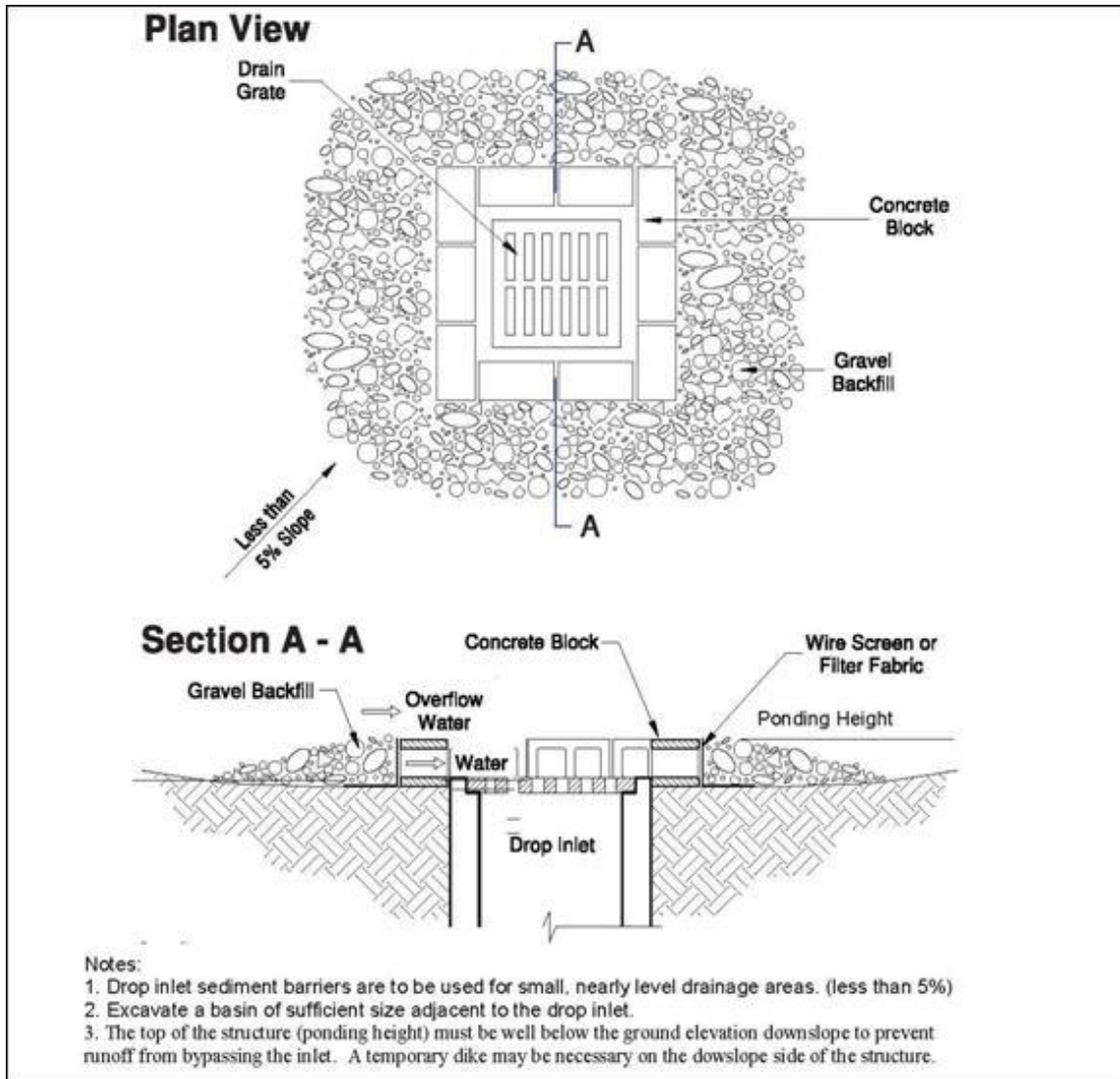

FIGURE SC-4-1 BLOCK AND GRAVEL FILTER

From: Stormwater Management Manual for Western Washington, Washington Department of Ecology, 2001

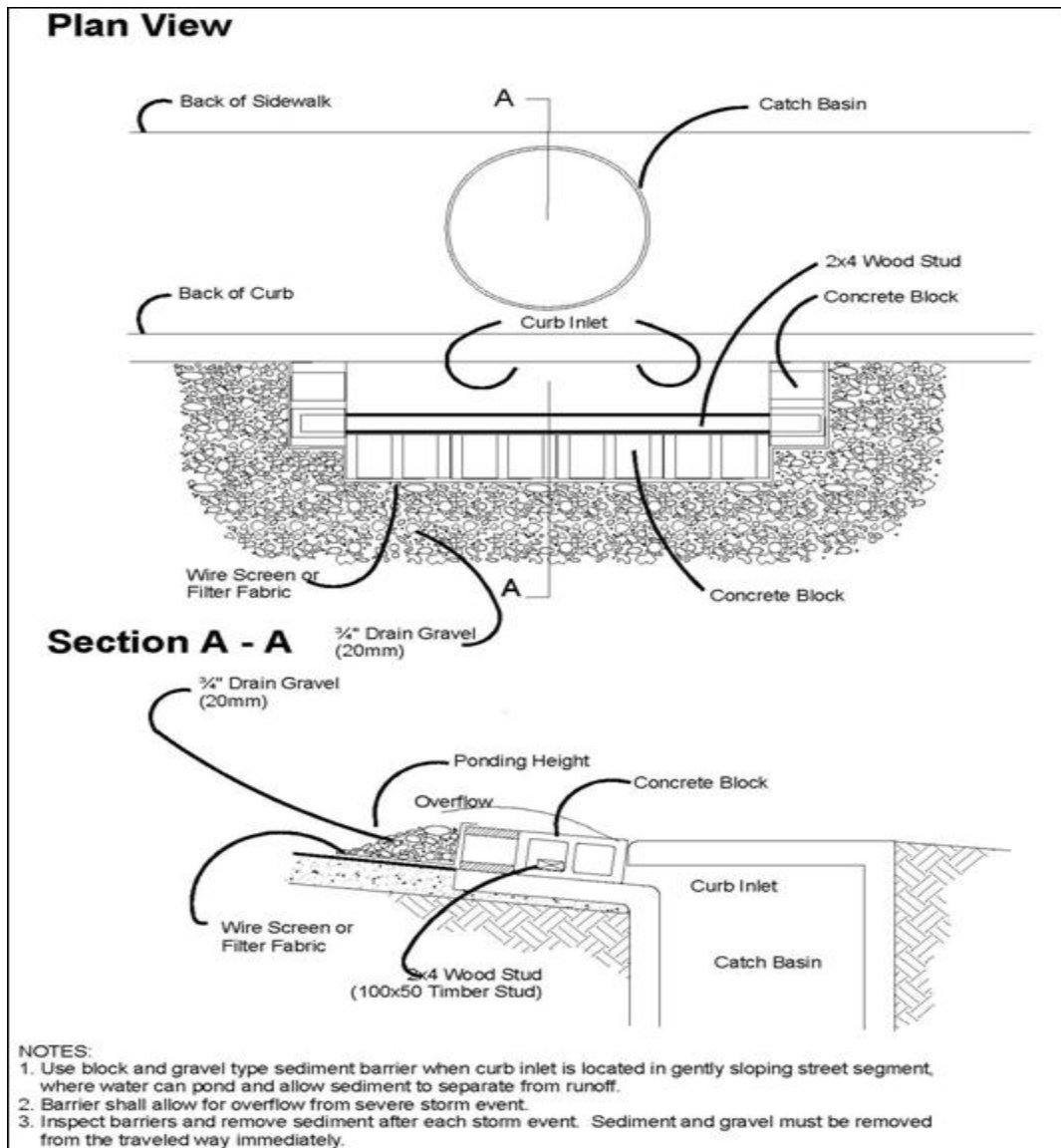

FIGURE SC-4-2 BLOCK AND GRAVEL CURB INLET PROTECTION

From: Stormwater Management Manual for Western Washington, Washington Department of Ecology, 2001

5. BMP SC-5: Sandbag Curb Inlet Sediment Barrier.

Purpose. Sandbag curb inlet barriers are temporary sediment barriers consisting of sandbags placed on the uphill side of the inlet and overlapping onto the curb. Curb inlet sediment barriers are used to prevent sediment from entering the storm drain system in paved areas. **Refer to the Carson City Standard Details for Public Works Construction, Detail Number C-4.1.7, Storm Drain Inlet Protection, for additional information.**

Conditions of Use.

- Applicable to all construction sites where the roads are already paved with the curb inlets in place
- The sandbag barriers are useful on streets which receive runoff flows of less than 0.5 cubic feet per second (cfs) for the [~~ten-year, 24-hour~~] **10-year, 24-hour** design storm

Design and Installation Specifications.

- The sandbag curb inlet sediment barriers are for drainage areas of less than 1 acre
- Sandbag curb inlet sediment barriers are designed to keep sediment out of the storm drain system when the roads are already paved
- A small area of sediment storage should be provided behind the sandbags
- The sandbag should be of plastic woven material rather than burlap. Burlap bags rot and deteriorate, and as a result, can cause more problems if broken
- Clean washed sand should be used to fill the bags
- The sandbags should be placed in a curved row from the top of the curb to at least 3 feet into the street
- The row should be at least 6 feet from the inlet and curved at the ends, which should be pointing uphill
- Several layers of bags should be overlapped and packed tightly together in order to eliminate any spaces between the bags
- Leave a 6-inch gap in the middle of the top row of sandbags to serve as the spillway

Maintenance Standards.

- Inspect BMPs [~~prior to forecast rain,~~] **before forecasted** daily during extended rain events, after rain events, weekly during the rainy season, and at two-week intervals during the non-rainy season
- Sandbags exposed to sunlight will need to be replaced every two to three months due to degradation of the bags
- Reshape and replace sandbags as needed
- Repair washouts or other damage as needed

- Accumulated sediment should be removed and placed where it will not enter the storm drain. Sediment should be removed when the sediment accumulation reaches one-third of the barrier height. Sediment removed during maintenance may be incorporated into earthwork on the site or disposed at an appropriate location
- Additional sediment storage capacity can be obtained by constructing a series of sand bag barriers along the curb and gutter so that each barrier traps a small amount of sediment
- Remove sandbags when no longer needed. Remove sediment accumulation, and clean, regrade and stabilize the area

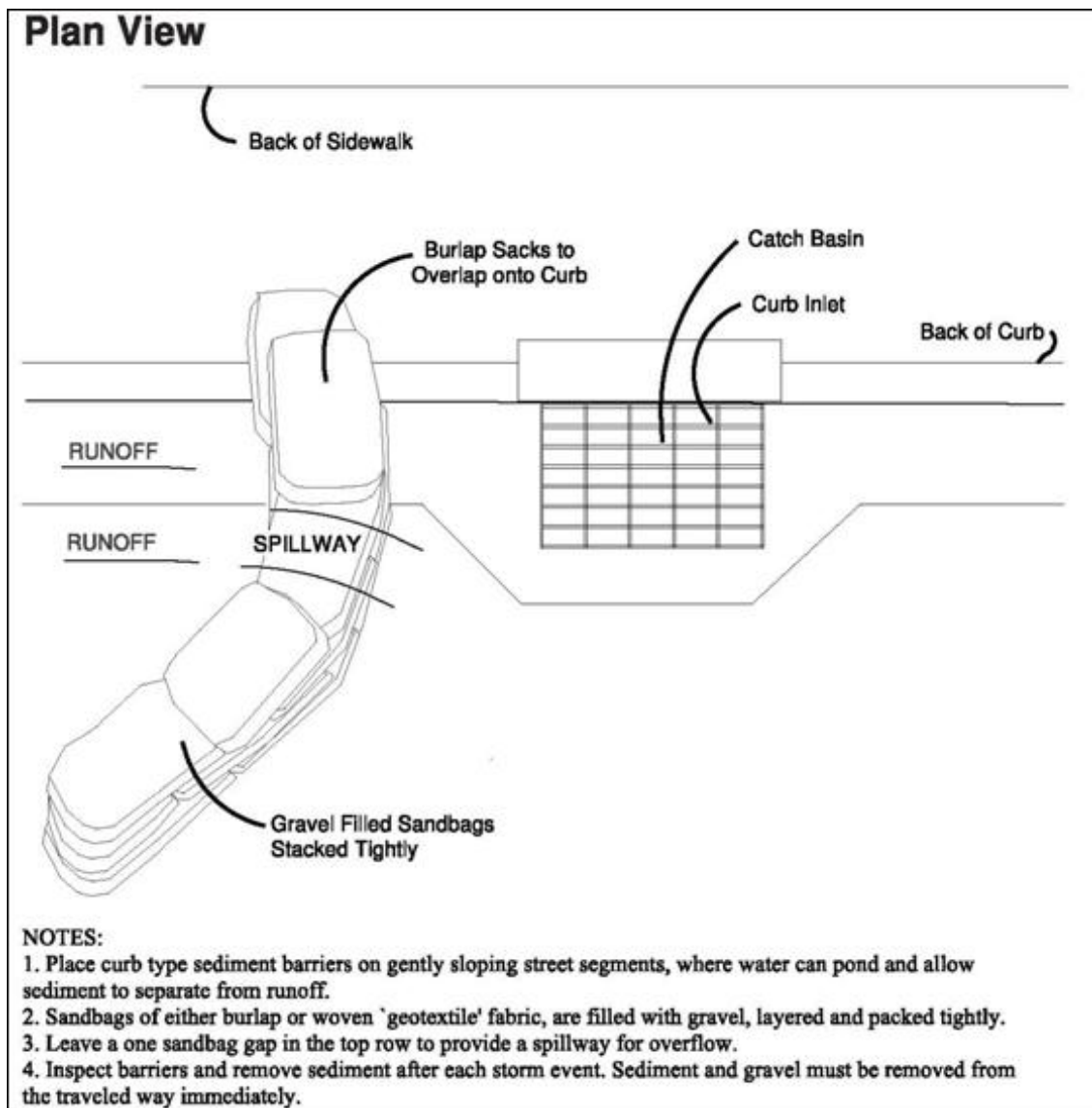

FIGURE SC-5-1 CURB AND GUTTER BARRIER

From: Stormwater Management Manual for Western Washington, Washington Department of Ecology, 2001]

6. BMP SC-6: Filter Strips.

Purpose. Filter strips, also known as vegetated strips, are strips of close growing vegetation located to receive runoff from diffuse sources, waterways, drains, and intermittent streams before the water enters a stream, or drainage pond. Filter strips reduce the transport of coarse sediment from a construction site by providing a temporary physical barrier to sediment and reducing the runoff velocities of overland flow.

Conditions of Use.

- Applies to all land uses where topography, soils, and moisture supplies are suitable for establishment of filter strips
- The runoff water should be spread as it enters the filter strip either by natural topography or by installation of level spreader ditches
- Use strips or areas of existing vegetation where possible
- Width of the filter strip should be adequate to allow settlement of the sediments. The width will vary depending on slope, type of vegetation and quantity of anticipated runoff water
- Vegetated strips may be used down slope of all disturbed areas
- Vegetated strips are not intended to treat concentrated flows, nor are they intended to treat substantial amounts of overland flow. Any concentrated flows must be conveyed through the drainage system to a sediment pond. The only circumstance in which overland flow can be treated solely by a strip, rather than by a sediment pond, is when the following criteria are met:

Contributory Overland Flow

Average Slope	Slope Percent	Flow path Length
1.5H:1V or less	67% or less	100 feet
2H:1V or less	50% or less	115 feet
4H:1V or less	25% or less	150 feet
6H:1V or less	16.7% or less	200 feet
10H:1V or less	10% or less	250 feet

Design and Installation Specifications.

- The vegetated strip shall consist of a minimum of a 25-foot wide continuous strip of dense vegetation with a permeable topsoil. Grass covered, landscaped areas are generally not adequate because the volume of sediment overwhelms the grass. Ideally, vegetated strips shall consist of undisturbed native growth with a well-developed soil that allows for infiltration of runoff
- The slope within the strip shall not exceed 4H:1V
- The uphill boundary of the vegetated strip shall be delineated with clearing limits

Maintenance Standards.

- Inspect BMPs [~~prior to forecast~~] **before forecasted** rain, daily during extended rain events, after rain events, weekly during the rainy season, and at two-week intervals during the non-rainy season
- Any areas damaged by erosion or construction activity shall be seeded immediately and protected by mulch
- If more than 5 feet of the original vegetated strip width has had vegetation removed or is being eroded, sod must be installed

- If there are indications that concentrated flows are traveling across the buffer, surface water controls must be installed to reduce the flows entering the buffer, or additional perimeter protection must be installed

7. BMP SC-7: Silt Fence.

Purpose. Use of a silt fence reduces the transport of coarse sediment from a construction site by providing a temporary physical barrier to sediment and reducing the runoff velocities of overland flow. See Figure EC-7-1 for details on silt fence construction.

Conditions of Use.

- Silt fence may be used down slope of all disturbed areas
- Silt fence is not intended to treat concentrated flows, nor is it intended to treat substantial amounts of overland flow. Any concentrated flows must be conveyed through the drainage system to a sediment pond or trap. The only circumstance in which overland flow can be treated solely by a silt fence, rather than by a sediment pond or trap, is when the area draining to the fence is one acre or less and [~~10-year, 24-hour~~] **10-year, 24-hour** flow rates are less than 0.5 cfs
- Silt fences should not be constructed in streams or used in V-shaped ditches. They are not an adequate method of silt control for anything deeper than sheet or overland flow

Design and Installation Specifications.

- Drainage area of 1 acre or less or in combination with sediment basin in a larger site
- Maximum slope steepness (normal (perpendicular) to fence line) 1:1
- Maximum sheet or overland flow path length to the fence of 100 feet
- No flows greater than 0.5 cfs for [~~10-year, 24~~] **10-year, 24-hour** hour event
- The geotextile used shall meet the following standards. All geotextile properties listed below are minimum average roll values (i.e., the test result for any sampled roll in a lot shall meet or exceed the values shown in the following table):

Geotextile Standards

Polymeric Mesh AOS (ASTM D4751)	0.60 mm maximum for slit film woven (#30 sieve). 0.30 mm maximum for all other geotextile types (#50 sieve). 0.15 mm minimum for all fabric types (#100 sieve).
Water Permittivity (ASTM D4491)	0.02 sec-1 [minimum Grab] Minimum Grab Tensile Strength
(ASTM D4632)	180 lbs. Minimum for extra strength fabric. 100 lbs minimum for standard strength fabric.
Grab Tensile Strength (ASTM D4632)	30% maximum
Ultraviolet Resistance (ASTM D4355)	70% minimum

- Standard strength fabrics shall be supported with wire mesh, chicken wire, 2-inch × 2-inch wire, safety fence, or jute mesh to increase the strength of the fabric. Silt fence materials are available that have synthetic mesh backing attached
- Filter fabric material shall contain ultraviolet ray inhibitors and stabilizers to provide a minimum of six months of expected usable construction life at a temperature range of 0°F. to 120°F
- 100 percent biodegradable silt fence is available that is [~~strong, long-lasting, and can be left in place after the project is completed, if permitted by local regulations~~] **and long lasting**
- Standard Notes for construction plans and specifications follow
 - The contractor shall install and maintain temporary silt fences at the locations shown in the Plans. The silt fences shall be constructed in the areas of clearing, grading, or drainage prior to starting those activities. [~~A silt fence shall not be considered temporary if the silt fence must function beyond the life of the contract.~~] The silt fence shall prevent soil carried by runoff water from going beneath, through, or over the top of the silt fence, but shall allow the water to filter through the fence.
 - The minimum height of the top of silt fence shall be 2 feet and the maximum height shall be 2½ feet above the original ground surface.
 - The geotextile shall be sewn together at the point of manufacture, or at an approved location as determined by the Engineer, to form geotextile lengths as required. All sewn seams shall be located at a support post. Alternatively, two sections of silt fence can be overlapped, provided the Contractor can demonstrate, to the satisfaction of the Engineer, that the overlap is long enough and that the adjacent fence sections are close enough together to prevent silt laden water from escaping through the fence at the overlap.
 - The geotextile shall be attached on the up-slope side of the posts and support system with staples, wire, or in accordance with the manufacturer's recommendations. The geotextile shall be attached to the posts in a manner that reduces the potential for geotextile tearing at the staples, wire, or other connection device. Silt fence back-up support for the geotextile in the form of a wire or plastic mesh is dependent on the properties of the geotextile selected for use. If wire or plastic back-up mesh is used, the mesh shall be fastened securely to the up-slope of the posts with the geotextile being up-slope of the mesh back-up support.
 - The geotextile at the bottom of the fence shall be buried in a trench to a minimum depth of 4 inches below the ground surface. The trench shall be backfilled and the soil tamped in place over the buried portion of the geotextile, such that no flow can pass beneath the fence and scouring cannot occur. When wire or polymeric back-up support mesh is used,

the wire or polymeric mesh shall extend into the trench a minimum of 3 inches.

- The fence posts shall be placed or driven a minimum of 18 inches. A minimum depth of 12 inches is allowed if topsoil or other soft subgrade soil is not present and a minimum depth of 18 inches cannot be reached. Fence post depths shall be increased by 6 inches if the fence is located on slopes of 3:1 or steeper and the slope is perpendicular to the fence. If required post depths cannot be obtained, the posts shall be adequately secured by bracing or guying to prevent overturning of the fence due to sediment loading.
- Silt fences shall be located on contour as much as possible, except at the ends of the fence, where the fence shall be turned uphill such that the silt fence captures the runoff water and prevents water from flowing around the end of the fence.
- If the fence must cross contours, with the exception of the ends of the fence, gravel check dams placed perpendicular to the back of the fence shall be used to minimize concentrated flow and erosion along the back of the fence. The gravel check dams shall be approximately 1-foot deep at the back of the fence. It shall be continued perpendicular to the fence at the same elevation until the top of the check dam intercepts the ground surface behind the fence. The gravel check dams shall consist of crushed surfacing base course, gravel backfill for walls, or shoulder ballast. The gravel check dams shall be located every 10 feet along the fence where the fence must cross contours. The slope of the fence line where contours must be crossed shall not be steeper than 3:1.
- Wood, steel or equivalent posts shall be used. Wood posts shall have minimum dimensions of 2 inches by 2 inches by 3 feet minimum length, and shall be free of defects such as knots, splits, or gouges.
- Steel posts shall consist of either size No. 6 rebar or larger, ASTM A 120 steel pipe with a minimum diameter of 1-inch, U, T, L, or C shape steel posts with a minimum weight of 1.35 lbs./ft. or other steel posts having equivalent strength and bending resistance to the post sizes listed. The spacing of the support posts shall be a maximum of 6 feet.
- Fence back-up support, if used, shall consist of steel wire with a maximum mesh spacing of 2 inches, or a prefabricated polymeric mesh. The strength of the wire or polymeric mesh shall be equivalent to or greater than 180 lbs. grab tensile strength. The polymeric mesh must be as resistant to ultraviolet radiation as the geotextile it supports.
- Silt fence installation using the slicing method specification details follow. Refer to Figure EC-7-2 for slicing method details
 - The base of both end posts must be at least 2 to 4 inches above the top of the silt fence fabric on the middle posts for ditch checks to drain

properly. Use a hand level or string level, if necessary, to mark base points before installation.

- Install posts 3 to 4 feet apart in critical retention areas and 6 to 7 feet apart in standard applications.
- Install posts 24 inches deep on the downstream side of the silt fence, and as close as possible to the fabric, enabling posts to support the fabric from upstream water pressure.
- Install posts with the nipples facing away from the silt fence fabric.
- Attach the fabric to each post with three ties, all spaced within the top 8 inches of the fabric. Attach each tie diagonally 45 degrees through the fabric, with each puncture at least one (1) inch vertically apart. In addition, each tie should be positioned to hang on a post nipple when tightening to prevent sagging.
- Wrap approximately 6 inches of fabric around the end posts and secure with 3 ties.
- No more than 24 inches of a 36-inch fabric is allowed above ground level.
- The rope lock system must be used in all ditch check applications.
- The installation should be checked and corrected for any deviation before compaction. Use a flat-bladed shovel to tuck fabric deeper into the ground if necessary.
- Compaction is vitally important for effective results. Compact the soil immediately next to the silt fence fabric with the front wheel of the tractor, skid steer, or roller exerting at least 60 pounds per square inch. Compact the upstream side first and then each side twice for a total of four trips.

Maintenance Standards.

- Inspect BMPs [~~prior to forecast~~] **before forecasted** rain, daily during extended rain events, after rain events, weekly during the rainy season, and at two-week intervals during the non-rainy season
- Any damage shall be repaired immediately
- If concentrated flows are evident uphill of the fence, they must be intercepted and conveyed to a sediment pond or trap
- It is important to check the uphill side of the fence for signs of the fence clogging and acting as a barrier to flow and then causing channelization of flows parallel to the fence. If this occurs, replace the fence or remove the trapped sediment
- Sediment deposits shall either be removed when the deposit reaches approximately one-third the height of the silt fence, or a second silt fence shall be installed

- If the filter fabric (geotextile) has deteriorated due to ultraviolet breakdown, it shall be replaced

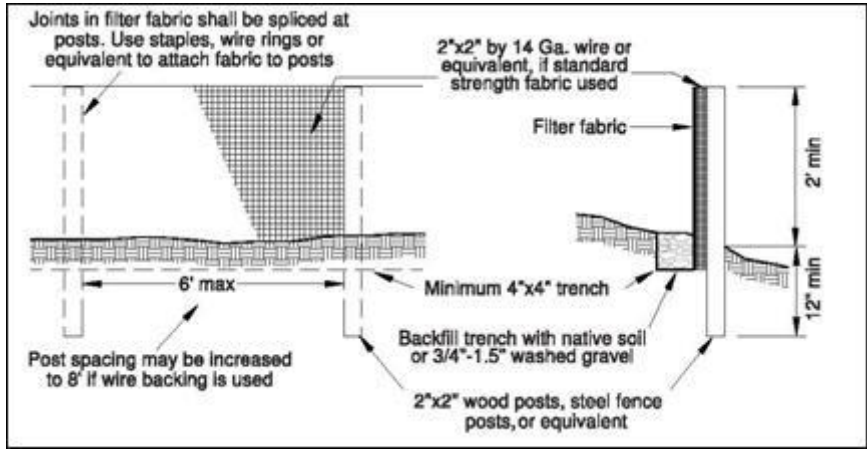

FIGURE EC-7-1 SILT FENCE

From: Stormwater Management Manual for Western Washington, Washington Department of Ecology, 2001

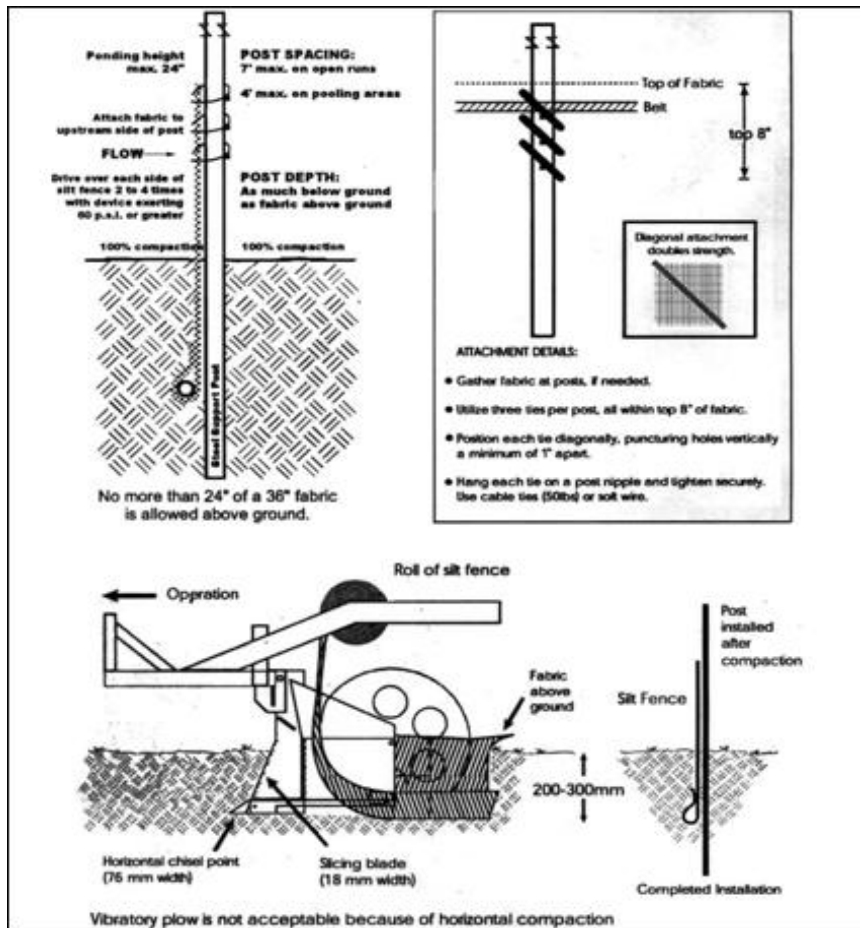

FIGURE EC-7-2 SILT FENCE INSTALLATION BY SLICING METHOD

From: Stormwater Management Manual for Western Washington, Washington Department of Ecology, 2001

8. BMP SC-8: Gravel Filter Berm.

Purpose. A gravel filter berm is constructed on rights-of-way or traffic areas within a construction site to capture and retain runoff from construction sites or roadways, to allow sediments to settle out, and to direct runoff water through filter berms at outlets to stabilize drainage ways.

Conditions of Use.

- Where a temporary measure is needed to retain sediment from rights-of-way or in traffic areas on construction sites
- Applicable to relatively flat construction sites and should be installed on the down slope sides of the disturbed areas

Design and Installation Specifications.

- Berm material shall be ¾ to 3 inches in size, washed well-graded gravel or crushed rock with less than 5 percent fines
- Spacing of berms:

- o Every 300 feet on slopes less than 5 percent
- o Every 200 feet on slopes between 5 percent and 10 percent
- o Every 100 feet on slopes greater than 10 percent
- Berm dimensions:
 - o 1 foot high with 3:1 side slopes
 - o 8 linear feet per 1 cfs runoff based on the 10-year, 24-hour design storm
- Berm should be mounded along the contour of the slope at the downhill side of the construction site
- The height of the ridge should be sufficient to contain the specified volume of runoff

Maintenance Standards.

- Inspect BMPs [~~prior to forecast~~] **before forecasted** rain, daily during extended rain events, after rain events, weekly during the rainy season, and at two-week intervals during the non-rainy seasons
- Sediment that accumulates in the BMP shall be removed when the sediment height reaches one-third of the barrier height. Sediment removed during maintenance may be incorporated into earthwork on the site or disposed at an appropriate location.
- Replace rock and filter material as needed

9. BMP SC-9: Gravel Bag Berm.

Purpose. A gravel bag berm is a series of gravel-filled bags placed on a level contour to intercept sheet flows. Gravel bags pond sheet flow runoff, allowing sediment to settle out, and release runoff slowly as sheet flows, preventing erosion.

Conditions of Use.

- Gravel Bag berms may be suitable:
 - ✓ As a linear sediment control measure
 - ✓ Below the toe of slopes and erodible slopes
 - ✓ As sediment traps at culvert/pipe outlets
 - ✓ Below other small cleared areas
 - ✓ Along the perimeter of a site
 - ✓ Down slope of exposed soil areas
 - ✓ Around temporary stockpiles and spoil areas
 - ✓ Parallel to a roadway to keep sediment off paved areas
 - ✓ Along streams and channels

- As linear erosion control measure:
 - ✓ Along the face and at grade breaks of exposed and erodible slopes to shorten slope length and spread runoff as sheet flow
 - ✓ At the top of slopes to divert runoff away from disturbed slopes
 - As check dams across mildly sloped construction roads

Limitations.

- Gravel bag berms may be difficult to remove
- Removal problems limit their usefulness in landscaped areas
- Gravel bag berms may not be appropriate for drainage areas greater than 5 acres
- Runoff will pond upstream of the filter, possibly causing flooding if sufficient space does not exist
- Degraded gravel bags may rupture when removed, spilling contents
- Installation can be labor intensive
- Berms may have limited durability for long-term projects
- When used to detain concentrated flows, maintenance requirements increase

Design and Installation Specifications.

- Locate gravel bag berms on level contours. Slopes between 20:1 and 2:1 (H:V): Gravel bags should be placed at a maximum interval of 50 ft. with the first row near the slope toe. Slopes 2:1 (H:V) or steeper: Gravel bags should be placed at a maximum interval of 25 ft (a closer spacing is more effective), with the first row placed on slope toe
- Turn the ends of the gravel bag barriers up slope to prevent runoff from going around the berm
- Allow sufficient space up slope from the gravel bag berm to allow ponding, and to provide room for sediment storage
- For installation near the toe of the slope, consider moving the gravel bag barriers away from the slope toe to facilitate cleaning. To prevent flows behind the barrier, bags can be placed perpendicular to a berm to serve as cross barriers
- Drainage area should not exceed 5 acres
- In Non-Traffic Areas:
 - ✓ Height = 18 in. maximum
 - ✓ Top width = 24 in. minimum for three or more layer construction
 - ✓ Top width = 12 in. minimum for one or two layer construction
 - ✓ Side slopes = 2:1 or flatter

- In Construction Traffic Areas:
 - ✓ Height = 12 in. maximum
 - ✓ Top width = 24 in. minimum for three or more layer construction
 - ✓ Top width = 12 in. minimum for one or two layer construction
 - ✓ Side slopes = 2:1 or flatter
- Butt ends of bags tightly:
- On multiple rows, or multiple layer construction, overlap butt joints of adjacent row and row beneath
- Use a pyramid approach when stacking bags
- Bag Material: Bags should be woven polypropylene, polyethylene or polyamide fabric, minimum unit weight of 4 ounces/yd², Mullen burst strength exceeding 300 lb/in² in conformance with the requirements of ASTM designation D3786, and ultraviolet stability exceeding 70% in conformance with the requirements in ASTM designation D4355
- Bag Size: Each gravel-filled bag should have a length of 18 in., width of 12 in., thickness of 3 in., and mass of approximately 33 lbs. Bag dimensions are nominal, and may vary based on locally available materials
- Fill Material: Fill material should be 0.5 to 1 in. Class 2 aggregate base, clean and free from clay, organic matter, and other deleterious material, or other suitable open graded, non-cohesive, porous gravel

Maintenance Standards.

- Inspect BMPs [~~prior to forecast~~] **before forecasted** rain, daily during extended rain events, after rain events, weekly during the rainy season, and at two-week intervals during the non-rainy season
- Gravel bags exposed to sunlight will need to be replaced every two to three months due to degrading of the bags
- Reshape or replace gravel bags as needed
- Repair washouts or other damage as needed
- Sediment that accumulates in the BMP must be periodically removed in order to maintain BMP effectiveness. Sediment should be removed when the sediment accumulation reaches one-third of the barrier height. Sediment removed during maintenance may be incorporated into earthwork on the site or disposed at an appropriate location
- Remove gravel bag berms when no longer needed. Remove sediment accumulation and clean, re-grade, and stabilize the area. Removed sediment should be incorporated in the project or disposed of

10. BMP SC-10: Interceptor Dike and Swale.

Purpose. Provide a ridge of compacted soil, or a ridge with an upslope swale, at the top or base of a disturbed slope or along the perimeter of a disturbed construction area to convey stormwater. Use the dike and/or swale to intercept the runoff from unprotected areas and direct it to areas where erosion can be controlled. This can prevent storm runoff from entering the work area or sediment-laden runoff from leaving the construction site.

Conditions of Use.

- Where the runoff from an exposed site or disturbed slope must be conveyed to an erosion control facility that can safely convey the stormwater
- Locate upslope of a construction site to prevent runoff from entering disturbed area
- When placed horizontally across a disturbed slope, it reduces the amount and velocity of runoff flowing down the slope
- Locate down slope to collect runoff from a disturbed area and direct it to a sediment basin

Design and Installation Specifications.

- Dike and/or swale and channel must be stabilized with temporary or permanent vegetation or other channel protection during construction
- Channel requires a positive grade for drainage, steeper grades require channel protection and check dams
- Construct trench along the slope contour including a conveyance to outlet flow to a level spreader or other stabilized discharge
- Place excavated materials on the down slope side of the trench or swale and spread to conform to the natural slope
- Review construction for areas where overtopping may occur
- Can be used at top of new fill before vegetation is established
- May be used as a permanent diversion channel to carry the runoff
- Sub-basin tributary area should be one acre or less
- Design capacity for 10-year, 24-hour storm for temporary facilities, 25-year, 24-hour storm for permanent facilities

Interceptor dikes shall meet the following criteria:

Top Width	2 feet minimum	
Height	1.5 feet minimum on berm	
Side Slope	2:1 or flatter	
Grade	Depends on topography, however, dike system minimum is 0.5%, maximum is 1%	
Compaction	Minimum of 90 percent ASTM D698 standard proctor.	
Horizontal Spacing of Interceptor Dikes:		
Average Slope	Slope Percent	Flow path Length
20H:1V or less	3-5%	300 feet
(10 to 20)H:1V	5-10%	200 feet
(4 to 10)H:1V	10-25%	100 feet
(2 to 4)H:1V	25-50%	50 feet
Stabilization depends on velocity and reach:		
Slopes <5%	Seed and mulch applied within 5 days of dike construction (see EC-15, Mulching)	
Slopes 5 - 50%	Dependent on runoff velocities and dike materials. Stabilization should be done immediately using either sod or riprap or other measures to avoid erosion.	

- The upslope side of the dike shall provide positive drainage to the dike outlet. No erosion shall occur at the outlet. Provide energy dissipation measures as necessary. Sediment-laden runoff must be released through a sediment trapping facility
- Minimize construction traffic over temporary dikes. Use temporary cross culverts for channel crossing

Interceptor swales shall meet the following criteria:

Bottom Width	2 feet minimum; the bottom cross-section shall be level
Depth	1-foot minimum
Side Slope	2:1 or flatter
Grade	Maximum 5 percent, with positive drainage to a suitable outlet (such as a sediment pond or trap).
Stabilization	Seed as per <i>EC-21, Seeding practices</i> , or <i>EC-11, Channel Lining</i> , 12 inches thick of riprap pressed into the bank and extending at least 8 inches vertical from the bottom.

Maintenance Standards.

- Inspect diversion dikes and interceptor swales once a week and after every rainfall
- Immediately remove sediment from the flow area
- Damage caused by construction traffic or other activity must be repaired before the end of each working day
- Check outlets and make timely repairs as needed to avoid gully formation. When the area below the temporary diversion dike is permanently stabilized, remove the dike and fill and stabilize the channel to blend with the natural surface

11. BMP SC-11: Brush Barrier.

Purpose. The purpose of brush barriers is to reduce the transport of coarse sediment from a construction site by providing a temporary physical barrier to sediment and reducing the runoff velocities of overland flow.

Conditions of Use.

- Brush barriers may be used down slope of all disturbed areas of less than one-quarter acre
- Brush barriers are not intended to treat concentrated flows, nor are they intended to treat substantial amounts of overland flow. Any concentrated flows must be conveyed through the drainage system to a sediment pond or trap. The only circumstance in which overland flow can be treated solely by a barrier, rather than by a sediment pond or trap, is when the area draining to the barrier is small
- Brush barriers should only be installed parallel to contours

Design and Installation Specifications.

- Height 2 feet (minimum) to 5 feet (maximum)
- Width 5 feet at base (minimum) to 15 feet (maximum)
- Filter fabric (geotextile) may be anchored over the brush berm to enhance the filtration ability of the barrier. Ten-ounce burlap is an adequate alternative to filter fabric
- Chipped site vegetation, composted mulch, or wood-based mulch (hog fuel) can be used to construct brush barriers
- A 100 percent biodegradable installation can be constructed using 10-ounce burlap held in place by wooden stakes. Figure SC-11-1 depicts a typical brush barrier

Maintenance Standards.

- Inspect BMPs [~~prior to forecast~~] **before forecasted** rain, daily during extended rain events, after rain events, weekly during the rainy season, and at two-week intervals during the non-rainy season
- There shall be no signs of erosion or concentrated runoff under or around the barrier. If concentrated flows are bypassing the barrier, it must be expanded or augmented by toed-in filter fabric
- The dimensions of the barrier must be maintained

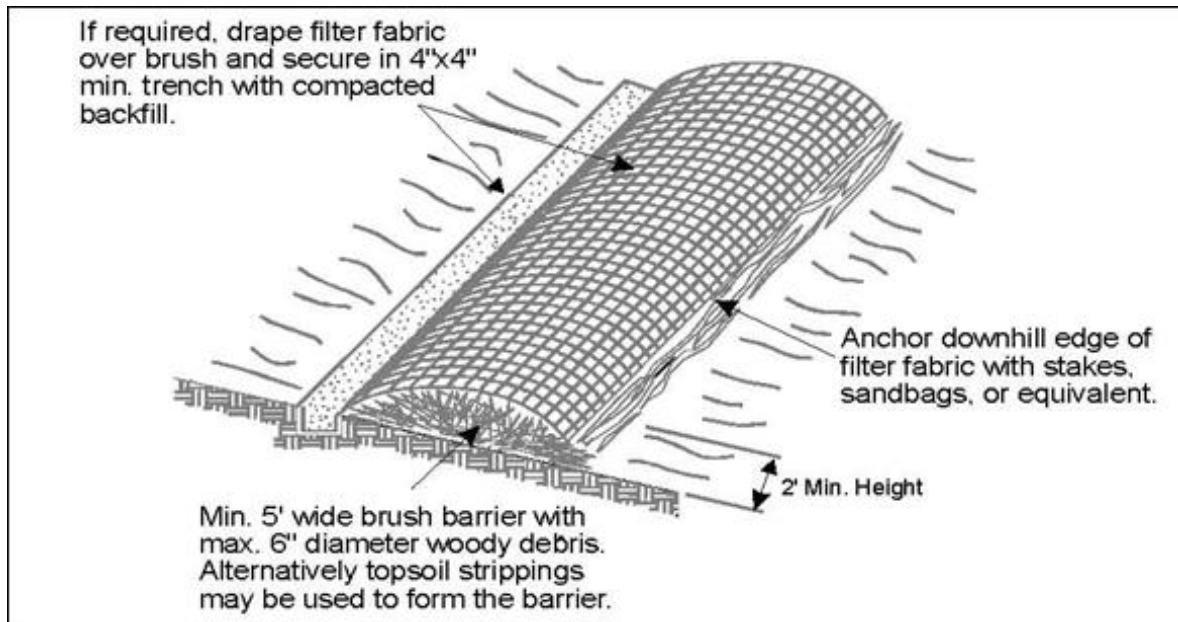

FIGURE SC-11-1 BRUSH BARRIER

12. BMP SC-12: Willow Wattles.

Purpose. Wattling is a revegetation technique consisting of placing bundles of willow cuttings in shallow trenches, on the contour of either cut or fill slopes to stabilize cut or fill slopes, to stabilize the surface, to reduce the velocity of surface runoff, to trap sediment, to increase infiltration, and to establish vegetation.

Conditions of Use.

- Applicable to surface disturbances involving cut or fill slopes
- Angle of repose is excessively steep
- As a type of revegetation, wattling is applicable on moist site or seeped areas
- Wattling is a valuable method to help achieve surface stability on a cut or fill slope, which is near its angle of repose, but continues to erode due to surface runoff
- Wattling bundles can vegetatively root and sprout and continue to stabilize slope surfaces as a revegetation planting. Rooting and sprouting will occur if adequate moisture is available at the time of placement and the first growing season
- Temporary irrigation can be very effective during establishment
- The placement of the wattling bundles along the contours can reduce slope lengths, which can provide long, uninterrupted paths for surface runoff
- The rows of wattling bundles act as small sediment traps and increases the amount of infiltration on site. Wattling should not be prescribed as a treatment on cut banks with shallow soils. The increased infiltration will saturate the subsoil and may lead to soil slippage and landslides

Design Criteria. The followings steps for preparing and placing the wattling bundles are recommended:

- Wattling bundles should be prepared from living branches of willow (*Salix* spp.) within or near the project area. Willow is the ideal material because it sprouts and roots easily, branches are long, straight, and flexible. Wattling material can be cut with lopping shears, chain saws, or power brush cutting saws
- Wattling bundles may vary length, depending on the material available. Bundles 5 feet long are the easiest to work with. Bundles shall taper at the ends and shall be 1 to ½ feet longer than the average length of stems used to achieve this taper. The butts of individual stems shall not vary more than one half inch in diameter
- Stems shall be placed alternately (randomly) in each bundle so that approximately one-half of the butt ends are at each end of the bundle
- When compressed firmly and tied, each bundle shall be approximately eight inches in diameter
- Bundles shall be tied on not more than 15-inch centers with two warps of binder twine or heavier tying material with a ~~[nonslipping]~~ **non-slipping** knot
- Bundles shall be prepared in advance of placement and kept covered and wet. They may be prepared up to seven days in advance of placement
- Grade for the wattling trenches shall be stakes with an Abney level, or similar device, and shall follow parallel to slope contours (horizontal)
- Trenches shall be three feet vertical spacing (or such other spacing specified. Economics may dictate wider placement)
- Bundles shall be laid in trenches dug to approximately one-half the diameter of the bundles, with ends of bundles overlapping at least 12 inches. The overlap shall be as long as necessary to permit staking as specified below
- Bundles shall be staked firmly in place with vertical stakes on the downhill side of the wattling. Vertical stakes should be spaced not more than 18 inches on center and diagonal stakes through the bundles on not more than 20-inch centers. Where bundle overlap occurs between previously set bottom or guide stakes, an additional bottom stake shall be used on the midpoint of the overlap. Bundle overlaps shall be "tied" with a diagonal stake through the ends of both bundles
- Stakes may be made of live wattling material greater than 1-½ inches in diameter or they may be construction stakes. Reinforcing bar may be substituted only as specified below
- All stakes shall be driven to a firm hold and a minimum of 18 inches deep. Where soils are soft and 24-inch stakes are not solid ~~[(i.e. if they]~~ **or** can **otherwise** be moved by ~~[hand), 36-inch stakes shall]~~ **hand, 36-inch stakes**

must be used. Where soils are so compacted that 24 inch stakes cannot be driven 18 inches deep, $\frac{3}{8}$ - $\frac{1}{2}$ inch steel reinforcing bar shall be used for staking

- Work shall progress from the bottom of the cut or fill toward the top and each row shall be covered with soil and packed firmly behind and on the uphill side of the wattling by tamping or by walking on the wattling as the work progresses or by a combination of these methods
- The downhill "lip" of the wattling bundle shall be left exposed when staking and covering are completed. However, the preceding specifications must be rigorously adhered to

Maintenance Standards.

- Inspect BMPs [~~prior to forecast~~] **before forecasted** rain, daily during extended rain events, after rain events, weekly during the rainy season, and at two-week intervals during the non-rainy season
- Inspection and repair [~~is~~] **are** especially important during the first year
- Immediately replace or repair any stakes or bundles that have worked out of the ground
- Immediately repair any slope sloughing or gully formed due to failure of the wattles

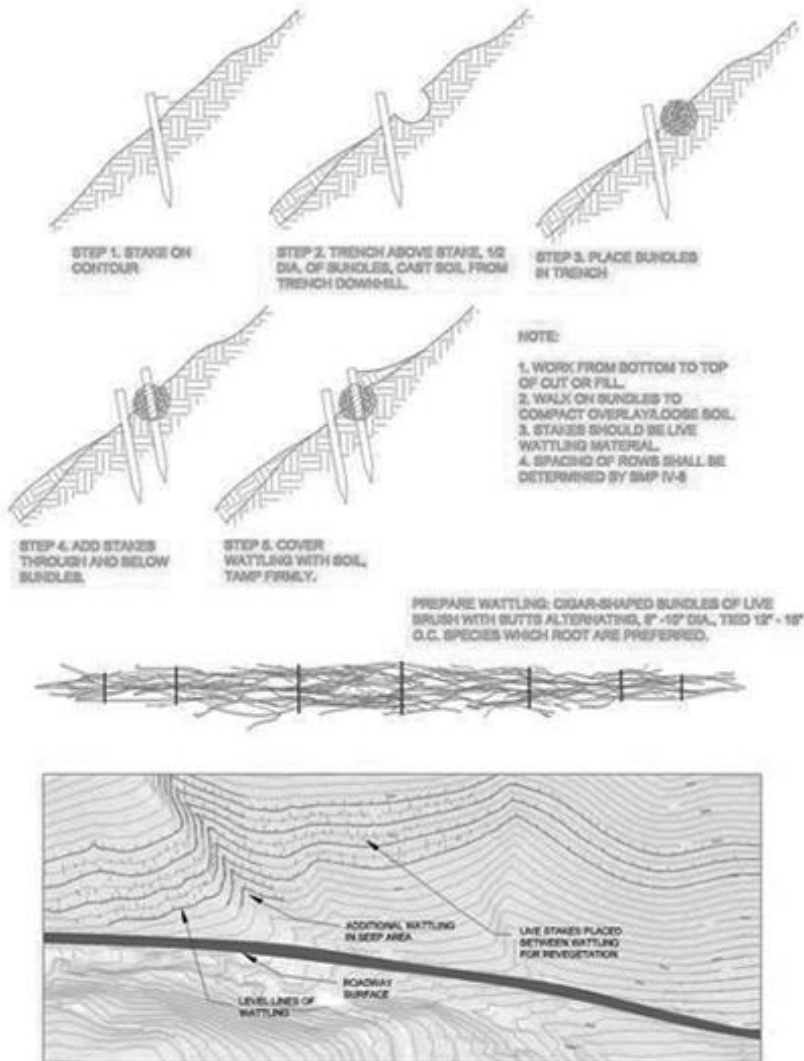

FIGURE SC-12-1 WATTLING

From: Handbook of Best Management Practices, Nevada Division of Environmental Protection and Nevada Division of Conservation Districts, 1994

13. BMP SC-13: Straw Wattles.

Purpose. Straw wattles are temporary erosion and sediment control barriers consisting of straw that is wrapped in biodegradable tubular plastic or similar encasing material. They reduce the velocity and can spread the flow of rill and sheet runoff, and can capture and retain sediment. Straw wattles are typically 8 to 10 inches in diameter and 25 to 30 feet in length. The wattles are placed in shallow trenches and staked along the contour of disturbed or newly constructed slopes.

Conditions of Use.

- Disturbed areas that require immediate erosion protection

- Exposed soils during the period of short construction delays, or over winter months
- On slopes requiring stabilization until permanent vegetation can be established
- Straw wattles are effective for one to two seasons
- If conditions are appropriate, wattles can be staked to the ground using willow cuttings for added revegetation
- Rilling can occur beneath wattles if not properly entrenched and water can pass between wattles if not tightly abutted together

Design Criteria.

- It is critical that wattles are installed perpendicular to the flow direction and parallel to the slope contour
- Narrow trenches should be dug across the slope on contour to a depth of 3 to 5 inches on clay soils and soils with gradual slopes. On loose soils, steep slopes, and areas with high rainfall, the trenches should be dug to a depth of 5 to 7 inches, or $\frac{1}{2}$ to $\frac{2}{3}$ of the thickness of the wattle
- Start building trenches and installing wattles from the base of the slope and work up. Excavated material should be spread evenly along the uphill slope and compacted using hand tamping or other methods
- Construct trenches at contour intervals of 3 to 30 feet apart depending on the steepness of the slope, soil type, and rainfall. The steeper the slope the closer together the trenches
- Install the wattles snugly into the trenches and abut tightly end to end. Do not overlap the ends
- Install stakes at each end of the wattle, and at 4-foot centers along entire length of wattle
- If required, install pilot holes for the stakes using a straight bar to drive holes through the wattle and into the soil
- At a minimum, wooden stakes should be approximately $\frac{3}{4} \times \frac{3}{4} \times 24$ inches. Willow cuttings or $\frac{3}{8}$ -inch rebar can also be used for stakes
- Stakes should be driven through the middle of the wattle, leaving 2 to 3 inches of the stake protruding above the wattle

Maintenance Standards.

- Inspect BMPs [~~prior to forecast~~] **before forecasted** rain, daily during extended rain events, after rain events, weekly during the rainy season, and at two-week intervals during the non-rainy season
- Wattles may require maintenance to ensure they are in contact with soil and thoroughly entrenched, especially after significant rainfall on steep sandy soils

- Inspect the slope after significant storms and repair any areas where wattles are not tightly abutted or water has scoured beneath the wattles

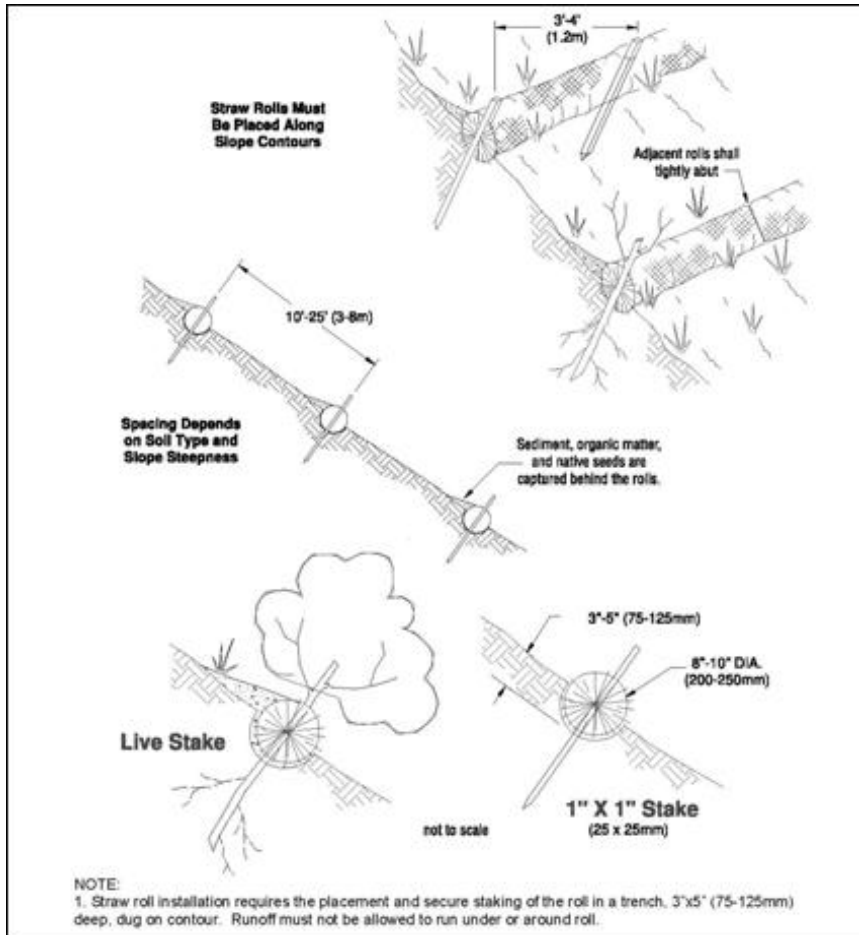

FIGURE SC-13-1 STRAW WATTLES

From: Stormwater Management Manual for Western Washington, Washington Department of Ecology, 2001

14. BMP SC-14: Sediment Trap.

Purpose. A sediment trap is a small temporary ponding area with a gravel outlet used to collect and store sediment from sites cleared and/or graded during construction. Sediment traps, along with other perimeter controls, shall be installed before any land disturbance takes place in the drainage area.

Conditions of Use. Prior to leaving a construction site, stormwater runoff must pass through a sediment pond or trap or other appropriate sediment removal best management practice. Non-engineered sediment traps may be used on-site prior to an engineered sediment trap or sediment pond to provide additional sediment removal capacity.

It is intended for use on sites where the tributary drainage area is less than 3 acres, with no unusual drainage features, and a projected build-out time of six months or less. The sediment trap is a temporary measure (with a design life of approximately 6 months) and shall be maintained until the site area is permanently protected against erosion by vegetation and/or structures.

Sediment traps and ponds are only effective in removing sediment down to about the medium silt size fraction. Runoff with sediment of finer grades (fine silt and clay) will pass through untreated, emphasizing the need to control erosion to the maximum extent first.

Whenever possible, sediment-laden water shall be discharged into onsite, relatively level, vegetated areas (see BMP SC-6 - Filter Strip). This is the only way to effectively remove fine particles from runoff unless chemical treatment or filtration is used. This can be particularly useful after initial treatment in a sediment trap or pond. The areas of release must be evaluated on a site-by-site basis in order to determine appropriate locations for and methods of releasing runoff. Vegetated wetlands shall not be used for this purpose. Frequently, it may be possible to pump water from the collection point at the downhill end of the site to an upslope vegetated area. Pumping shall only augment the treatment system, not replace it, because of the possibility of pump failure or runoff volume in excess of pump capacity.

All projects that are constructing permanent facilities for runoff quantity control should use the rough-graded or final-graded permanent facilities for traps and ponds. This includes combined facilities and infiltration facilities. When permanent facilities are used as temporary sedimentation facilities, the surface area requirement of a sediment trap or pond must be met. If the surface area requirements are larger than the surface area of the permanent facility, then the trap or pond shall be enlarged to comply with the surface area requirement. The permanent pond shall also be divided into two cells as required for sediment ponds. If permanent infiltration facilities are used for temporary sediment traps, the bottom of the trap must be kept at least two feet higher than the bottom elevation of the permanent facility. This will provide a vertical buffer to prevent sediment from plugging the native soils to be used for permanent infiltration. The permanent facility will be excavated to final depth once the site has been stabilized and the temporary trap is no longer necessary.

Either a permanent control structure or the temporary control structure (described in BMP SC-15, Temporary Sediment Pond) can be used. If a permanent control structure is used, it may be advisable to partially restrict the lower orifice with gravel to increase residence time while still allowing dewatering of the pond. A shut-off valve may be added to the control structure to allow complete retention of stormwater in emergency situations. In this case, an emergency overflow weir must be added.

A skimmer may be used for the sediment trap outlet if approved by Carson City.

Design and Installation Specifications.

- See Figures SC-14-1 and SC-14-2 for details
- If permanent runoff control facilities are part of the project, they should be used for sediment retention
- To determine the sediment trap geometry, first calculate the design surface area (SA) of the trap, measured at the invert of the weir. Use the following equation:

$$SA = FS(Q_2/V_s)$$

where

Q_2 = Design inflow based on the peak discharge from the developed 2-year, [24-hour] **24-hour** runoff event from the contributing drainage area as computed in the hydrologic analysis. The 10-year peak flow shall be used if the project size, expected timing and duration of construction, or downstream conditions warrant a higher level of protection. If no hydrologic analysis is required, the Rational Method may be used

V_s = The settling velocity of the soil particle of interest. The 0.02 mm (medium silt) particle with an assumed density of 2.65 g/cm³ has been selected as the particle of interest and has a settling velocity (V_s) of 0.00096 ft/sec

FS = A safety factor of 2 to account for non-ideal settling

Therefore, the equation for computing surface area becomes:

$$SA = 2 \times Q_2 / 0.00096 \text{ or}$$

2080 square feet per cfs of inflow

Note: Even if permanent facilities are used, they must still have a surface area that is at least as large as that derived from the above formula. If they do not, the pond must be enlarged.

- To aid in determining sediment depth, all sediment traps shall have a staff gauge with a prominent mark 1-foot above the bottom of the trap
- Sediment traps may not be feasible on utility projects due to the limited workspace or the short-term nature of the work. Portable tanks may be used in place of sediment traps for utility projects

Maintenance Standards.

- Inspect BMPs [~~prior to forecast~~] **before forecasted** rain, daily during extended rain events, after rain events, weekly during the rainy season, and at 2-week intervals during the non-rainy season
- Sediment shall be removed from the trap when it reaches 1-foot in depth
- Any damage to the pond embankments or slopes shall be repaired

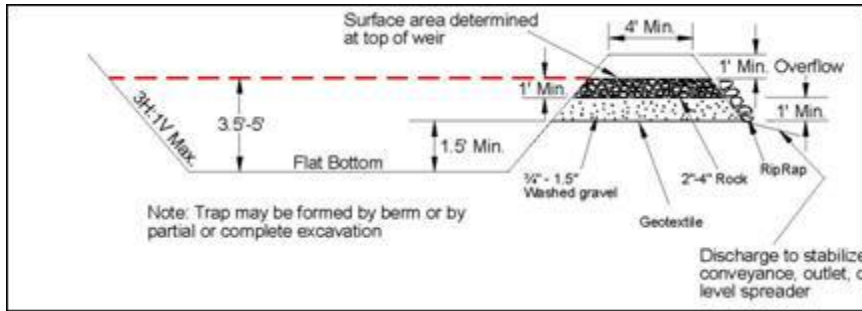

FIGURE SC-14-1 CROSS-SECTION OF SEDIMENT TRAP

From: Stormwater Management Manual for Western Washington, Washington Department of Ecology, 2001

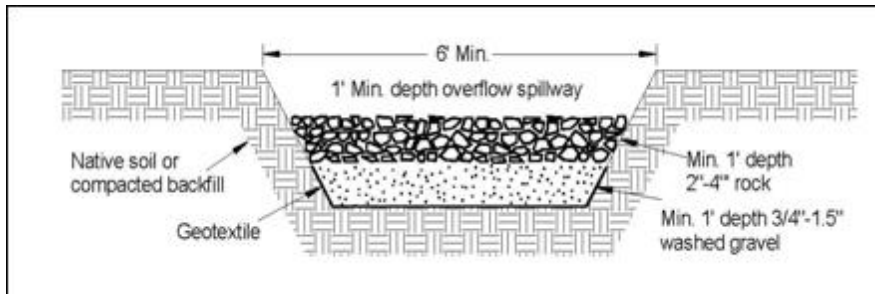

FIGURE SC-14-2 SEDIMENT TRAP OUTLET

From: Stormwater Management Manual for Western Washington, Washington Department of Ecology, 2001

15. BMP SC-15: Temporary Sediment Pond.

Purpose. Sediment ponds remove sediment from runoff originating from disturbed areas of the site. Sediment ponds are typically designed to remove sediment no smaller than medium silt (0.02 mm). Consequently, they usually reduce turbidity only slightly.

Conditions of Use.

- Prior to leaving a construction site, stormwater runoff must pass through a sediment pond or other appropriate sediment removal best management practice.
- A sediment pond shall be used where the contributing drainage area is 3 acres or more. Ponds must be used in conjunction with erosion control practices to reduce the amount of sediment flowing into the basin.

Design and Installation Specifications.

- Sediment basins must be installed only on sites where failure of the structure would not result in loss of life, damage to homes or buildings, or interruption of use or service of public roads or utilities. [~~Also, sediment traps and ponds are attractive to children and can be very dangerous.~~] Compliance with local ordinances regarding health and safety must be addressed. If fencing of the pond is required, the type of fence and its location shall be shown on the ESC plan

- Structures having a maximum height of 20 feet, and/or a maximum storage capacity of 20 acre-feet or larger are subject to dam safety regulations. Smaller impoundments may also be subject to dam safety regulations if they are determined to be "high-hazard" based on potential downstream impacts as determined by the Nevada Department of Water Resources
- See Figure SC-15-1, Figure SC-15-2, and Figure SC-15-3 for details
- If permanent runoff control facilities are part of the project, they should be used for sediment retention. The surface area requirements of the sediment basin must be met. This may require enlarging the permanent basin to comply with the surface area requirements. If a permanent control structure is used, it may be advisable to partially restrict the lower orifice with gravel to increase residence time while still allowing dewatering of the basin
- Use of infiltration facilities for sedimentation basins during construction tends to clog the soils and reduce their capacity to infiltrate. If infiltration facilities are to be used, the sides and bottom of the facility must only be rough excavated to a minimum of 2 feet above final grade. Final grading of the infiltration facility shall occur only when all contributing drainage areas are fully stabilized. The infiltration pretreatment facility should be fully constructed and used with the sedimentation basin to help prevent clogging
- Determining Pond Geometry
- Obtain the discharge from the hydrologic calculations of the peak flow for the 2-year, [~~24-hour~~] **24-hour** runoff event (Q_2). The 10-year peak flow shall be used if the project size, expected timing and duration of construction, or downstream conditions warrant a higher level of protection. If no hydrologic analysis is required, the Rational Method may be used

Determine the required surface area at the top of the riser pipe with the equation:

- To determine the sediment trap geometry, first calculate the design surface area (SA) of the trap, measured at the invert of the weir. Use the following equation:

$$SA = FS(Q_2/V_s)$$

where

Q_2 = Design inflow based on the peak discharge from the developed 2-year, 24 hour runoff event from the contributing drainage area as computed in the hydrologic analysis. The 10-year peak flow shall be used if the project size, expected timing and duration of construction, or downstream conditions warrant a higher level of protection. If no hydrologic analysis is required, the Rational Method may be used

V_s = The settling velocity of the soil particle of interest. The 0.02 mm (medium silt) particle with an assumed density of 2.65 g/cm³ has been selected as the particle of interest and has a settling velocity (V_s) of 0.00096 ft/sec

$FS =$ A safety factor of 2 to account for non-ideal settling

Therefore, the equation for computing surface area becomes:

$$SA = 2 \times Q_2 / 0.00096 \text{ or}$$

2080 square feet per cfs of inflow

Note: Even if permanent facilities are used, they must still have a surface area that is at least as large as that derived from the above formula. If they do not, the pond must be enlarged.

The basic geometry of the pond can now be determined using the following design criteria:

- Required surface area SA (from above) at top of riser
 - Minimum 3.5-foot depth from top of riser to bottom of pond
 - Maximum 3:1 interior side slopes and maximum 2:1 exterior slopes. The interior slopes can be increased to a maximum of 2:1 if 6 foot high chain-link fencing is provided at or above the maximum water surface
 - One foot of freeboard between the top of the riser and the crest of the emergency spillway
 - Flat bottom
 - Minimum 1-foot deep spillway
 - Length-to-width ratio between 3:1 and 6:1
- Sizing of Discharge Mechanisms. The outlet for the basin consists of a combination of principal and emergency spillways. These outlets must pass the peak runoff expected from the contributing drainage area for a 100-year storm, [~~24-hour~~] **24-hour** design. If, due to site conditions and basin geometry, a separate emergency spillway is not feasible, the principal spillway must pass the entire peak runoff expected from the 100-year storm. However, an attempt to provide a separate emergency spillway should always be made. The runoff calculations should be based on the site conditions producing the maximum amount of runoff, which is typically the developed paved condition, but could also be the rough graded condition if the developed site incorporates significant landscaping. The flow through the dewatering orifice cannot be utilized when calculating the 100-year storm elevation because of its potential to become clogged; therefore, available spillway storage must begin at the principal spillway riser crest.

The principal spillway designed by the procedures contained in this standard will result in some reduction in the peak rate of runoff. However, if the basin for a permanent stormwater detention pond is used for a temporary sedimentation basin, the control structure for the permanent pond can be used to maintain predevelopment discharge limitations. The size of the basin, the expected life of the construction project, the anticipated downstream effects and the anticipated weather conditions during construction, should be

considered to determine the need of additional discharge control. See Figure SC-15-4 for riser inflow curves.

Principal Spillway: Determine the required diameter for the principal spillway (riser pipe). The diameter shall be the minimum necessary to pass the pre-developed 10-year, ~~[24-hour]~~ **24-hour** peak flow (Q_{10}). Use Figure SC-15-4 to determine this diameter ($h = 1$ -foot).

Note: A permanent control structure may be used instead of a temporary riser.

Emergency Overflow Spillway: Determine the required size and design of the emergency overflow spillway for the developed 100-year, ~~[24-hour]~~ **24-hour** peak flow using the method contained in Division 14.

Dewatering Orifice: Determine the size of the dewatering orifice(s) (minimum 1-inch diameter) using a modified version of the discharge equation for a vertical orifice and a basic equation for the area of a circular orifice. Determine the required area of the orifice with the following equation:

$$A_o = \frac{A^s (2h)^{0.5}}{0.6 \times 3600 T g^{0.5}}$$

where A_o = orifice area (square feet)

A_s = pond surface area (square feet)

h = head of water above orifice (height of riser in feet)

T = dewatering time (24 hours)

g = acceleration of gravity (32.2 feet/second²)

$$A_o = \frac{A^s (2h)^{0.5}}{294,166}$$

Convert the required orifice area to the required diameter D of the orifice:

$$D = 24 \times \sqrt{A_o / \pi} = 13.53 \times \sqrt{A_o}$$

Where D = orifice diameter (inches)

The vertical, perforated tubing connected to the dewatering orifice must be at least 2 inches larger in diameter than the orifice to improve flow characteristics. The size and number of perforations in the tubing should be large enough so that the tubing does not restrict flow. The orifice should control the flow rate.

■ **Additional Design Specifications.**

■ The most common structural failure of sedimentation basins is caused by piping. Piping refers to two phenomena: (1) water seeping through fine-grained soil, eroding the soil grain by grain

and forming pipes or tunnels; and, (2) water under pressure flowing upward through a granular soil with a head of sufficient magnitude to cause soil grains to lose contact and capability for support.

■ The most common structural failure of sedimentation basins is caused by piping. Piping refers to two phenomena: (1) water seeping through fine-grained soil, eroding the soil grain by grain and forming pipes or tunnels; and, (2) water under pressure flowing upward through a granular soil with a head of sufficient magnitude to cause soil grains to lose contact and capability for support.

The most critical construction sequences to prevent piping will be:

1. Tight connections between riser and barrel and other pipe connections;
2. Adequate anchoring of riser;
3. Proper soil compaction of the embankment and riser footing;
4. Proper construction of anti-seep devices.

Maintenance Standards.

- Inspect BMPs [~~prior to forecast~~] **before forecasted** rain, daily during extended rain events, after rain events, weekly during the rainy season, and at two-week intervals during the non-rainy season
- Sediment shall be removed from the pond when it reaches 1-foot in depth
- Any damage to the pond embankments or slopes shall be promptly repaired

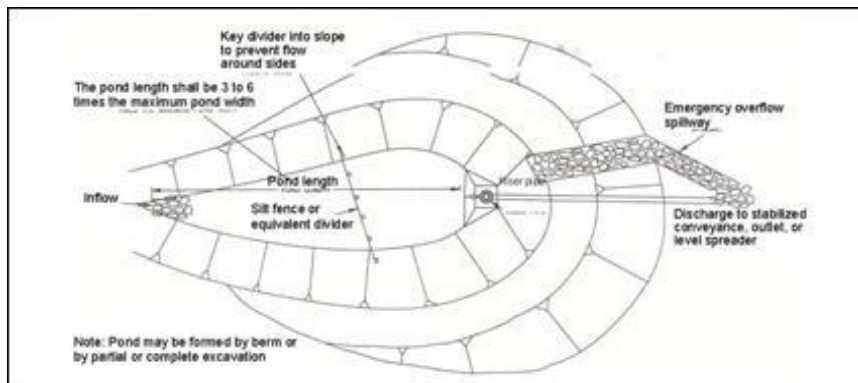

FIGURE SC-15-1 SEDIMENT POND PLAN VIEW

From: Stormwater Management Manual for Western Washington, Washington Department of Ecology, 2001

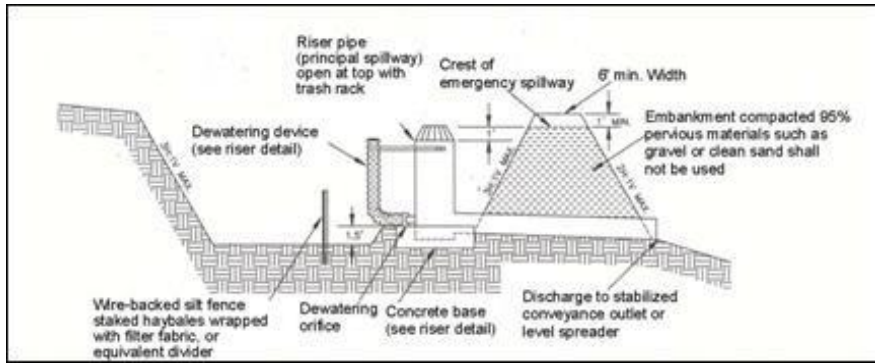

FIGURE SC-15-2 SEDIMENT POND CROSS SECTION

From: Stormwater Management Manual for Western Washington, Washington Department of Ecology, 2001

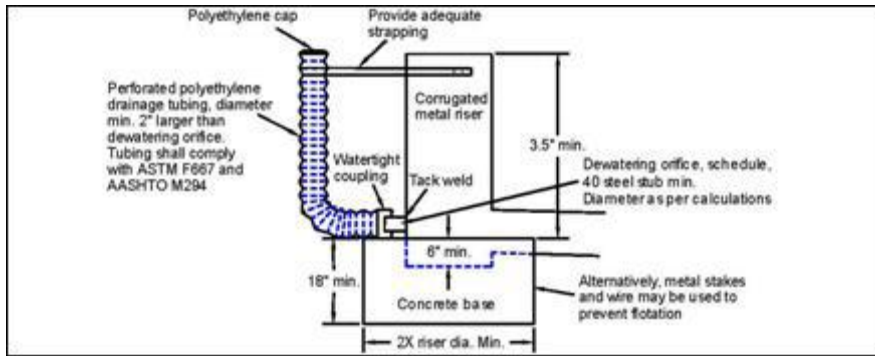

FIGURE SC-15-3 SEDIMENT POND RISER DETAIL

From: Stormwater Management Manual for Western Washington, Washington Department of Ecology, 2001

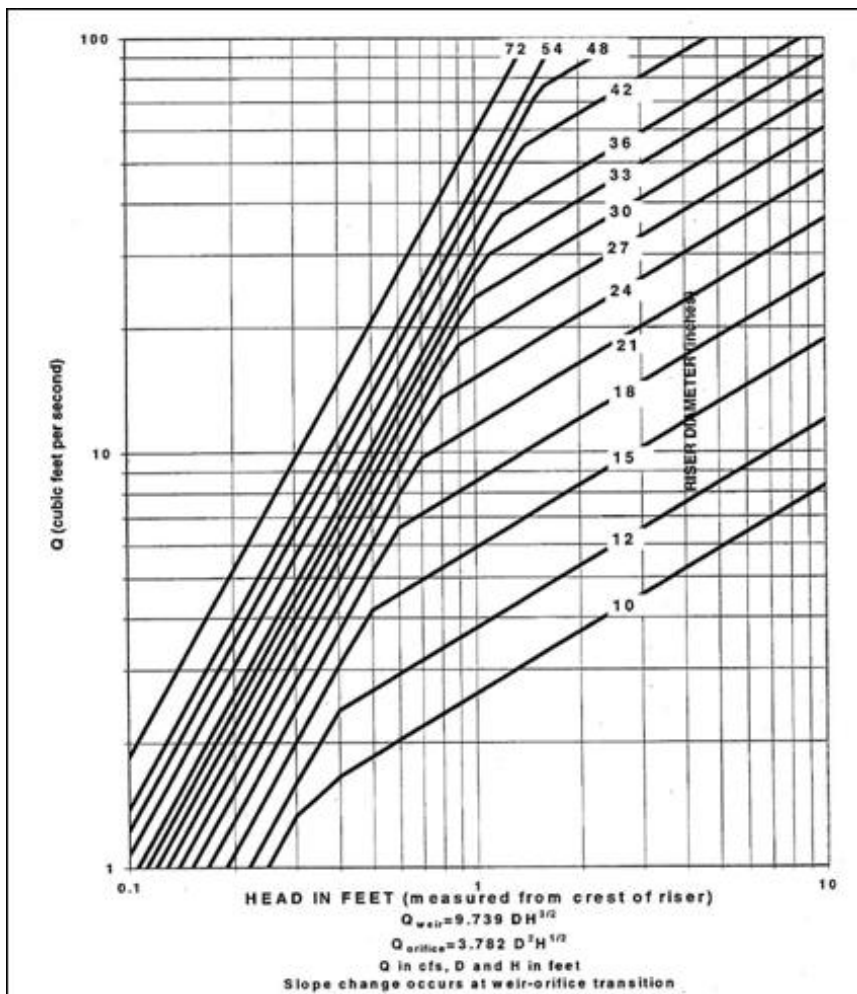

FIGURE SC-15-4 RISER INFLOW CURVES

From: Stormwater Management Manual for Western Washington, Washington Department of Ecology, 2001

16. BMP SC-16: Construction Stormwater Filtration.

Purpose. Filtration removes sediment from runoff originating from disturbed areas of the site.

Conditions of Use. Traditional BMPs used to control soil erosion and sediment loss from sites under development may not be adequate to ensure compliance with the water quality standard for turbidity in the receiving water. Filtration may be used in conjunction with gravity settling to remove sediment as small as fine silt (0.5 m). The reduction in turbidity will be dependent on the particle size distribution of the sediment in the stormwater. In some circumstances, sedimentation and filtration may achieve compliance with the water quality standard for turbidity. Filtration may also be used in conjunction with polymer treatment in a portable system to assure capture of the flocculated solids.

Design and Installation Specifications.

Background Information. Filtration with sand media has been used for over a century to treat water and wastewater. The use of sand filtration for treatment of stormwater has developed recently, generally to treat runoff from streets, parking lots, and residential areas. The application of filtration to construction stormwater treatment is currently under development.

[2] **Two** types of filtration systems may be applied to construction stormwater treatment: rapid and slow. Rapid sand filters are the typical system used for water and wastewater treatment. They can achieve relatively high hydraulic flow rates, on the order of 2 to 20 gpm/sf, because they have automatic backwash systems to remove accumulated solids. In contrast, slow sand filters have very low hydraulic rates, on the order of 0.02 gpm/sf, because they do not have backwash systems. To date, slow sand filtration has generally been used to treat stormwater. Slow sand filtration is mechanically simple in comparison to rapid sand filtration but requires a much larger filter area.

Filtration Equipment. Sand media filters are available with automatic backwashing features that can filter to 50 m particle size. Screen or bag filters can filter down to 5 m. Fiber wound filters can remove particles down to 0.5 m. Filters should be sequenced from the largest to the smallest pore opening. Sediment removal efficiency will be related to particle size distribution in the stormwater.

Treatment Process Description. Stormwater is collected at interception point(s) on the site and is diverted to a sediment pond or tank for removal of large sediment and storage of the stormwater before it is treated by the filtration system. The stormwater is pumped from the trap, pond, or tank through the filtration system in a rapid sand filtration system. Slow sand filtration systems are designed as flow through systems using gravity.

If large volumes of concrete are being poured, pH adjustment may be necessary.

Maintenance Standards.

- Rapid sand filters typically have automatic backwash systems that are triggered by a pre-set pressure drop across the filter. If the backwash water volume is not large or substantially more turbid than the stormwater stored in the holding pond or tank, backwash return to the pond or tank may be

appropriate. However, land application or another means of treatment and disposal may be necessary

- Screen, bag, and fiber filters must be cleaned and/or replaced when they become clogged
- Sediment shall be removed from the storage and/or treatment ponds as necessary Typically, sediment removal is required once or twice during a wet season and at the decommissioning of the ponds

C. Management Source Control BMPs.

1. BMP MC-1: Concrete Handling.

Purpose. Concrete work can generate process water and slurry that contain fine particles and high pH, both of which can violate water quality standards in the receiving water. This BMP is intended to minimize and eliminate concrete process water and slurry from entering waters of the State.

Conditions of Use.

- Any time concrete is used, these management practices shall be utilized
Concrete construction projects include, but are not limited to, the following:
 - Curbs
 - Sidewalks
 - Roads
 - Bridges
 - Foundations
 - Floors
 - Runways
 - {■
 - }

Design and Installation Specifications.

- Concrete truck chutes, pumps, and internals shall be washed out only into formed areas awaiting installation of concrete or asphalt
- Unused concrete remaining in the truck and pump shall be returned to the originating batch plant for recycling
- Hand tools including, but not limited to, screeds, shovels, rakes, floats, and trowels shall be washed off only into formed areas awaiting installation of concrete or asphalt
- Equipment that cannot be easily moved, such as concrete pavers, shall only be washed in areas that do not directly drain to natural or constructed stormwater conveyances

- Wash down from areas such as concrete aggregate driveways shall not drain directly to natural or constructed stormwater conveyances
- When no formed areas are available, wash water and leftover product shall be contained in a lined container. Contained concrete shall be disposed of in a manner that does not violate groundwater or surface water quality standards
- {■
- }

Maintenance Standards. Containers shall be checked for holes in the liner daily during concrete pours and repaired the same day. **Container should be checked daily for freeboard and, if necessary, replaced the same day.**

2. BMP MC-2: Sawcutting and Surfacing Pollution Prevention.

Purpose. Saw cutting and surfacing operations generate slurry and process water that contain fine particles and high pH (concrete cutting), both of which can violate the water quality standards in the receiving water. This BMP is intended to minimize and eliminate process water and slurry from entering waters of the State.

Conditions of Use. Anytime saw cutting or surfacing operations take place, these management practices shall be utilized. Saw cutting and surfacing operations include, but are not limited to, the following:

- Sawing
- Coring
- Grinding
- Roughening
- Hydro-demolition
- Bridge and road surfacing

Design and Installation Specifications.

- Slurry and cuttings shall be vacuumed during cutting and surfacing operations.
- Slurry and cuttings shall not remain on permanent concrete or asphalt pavement overnight.
- Slurry and cuttings shall not drain to any natural or constructed drainage conveyance.
- Collected slurry and cuttings shall be disposed of in a manner that does not violate groundwater or surface water quality standards.
- Process water that is generated during hydro-demolition, surface roughening or similar operations shall not drain to any natural or constructed drainage conveyance and shall be disposed of in a manner that does not violate groundwater or surface water quality standards.

- Cleaning waste material and demolition debris shall be handled and disposed of in a manner that does not cause contamination of water. If the area is swept with a pick-up sweeper, the material must be hauled out of the area to an appropriate disposal site.

Maintenance Standards. Continually monitor operations to determine whether slurry, cuttings, or process water could enter waters of the State. If inspections show that a violation of water quality standards could occur, stop operations and immediately implement preventive measures such as berms, barriers, secondary containment, and vacuum trucks.

3. BMP MC-3: Materials Management.

Purpose. Discharge of materials other than stormwater and authorized non-stormwater discharges is prohibited from construction sites. Non-stormwater discharges that may be allowed include but are not limited to irrigation of vegetative erosion control measures and pipe flushing and testing.

Waste management and materials pollution control BMPs are source control BMPs that prevent pollution by limiting or reducing potential pollutants at their source before they come in contact with stormwater. These BMPs involve day-to-day operations of the construction site and include operations under the control of the contractor. These BMPs are also referred to as "good housekeeping practices" which involve keeping a clean, orderly construction site. Waste management consists of implementing procedural and structural BMPs for handling, storing, and disposing of wastes generated by a construction project to prevent the release of waste materials into storm water runoff or discharges through proper management of solid, sanitary, hazardous and equipment related wastes.

Implementation.

Stockpile Management. Protection of stockpiles is a year-round requirement.

- ✓ Locate stockpiles away from stormwater flows, drainage courses and inlets
- ✓ Use temporary berms, dikes, silt fences, sandbags, gravel bags or straw bale barriers to protect stockpiles from storm water runoff and to prevent transport of storm water pollutants
- ✓ Place bagged materials on pallets and under cover
- ✓ Stockpiles should be covered or protected with plastic sheeting or soil stabilization measures during the rainy season
- ✓ Repair or replace perimeter controls and covers as needed to keep them functioning properly

Solid Waste Management. Solid wastes include trees and shrubs removed during land clearing, demolition of existing structures (rubble), packaging materials, scrap or surplus building materials, and domestic wastes (beverage cans, coffee cups, paper bags, etc.). Certain construction wastes may not necessitate stringent drainage related control during the non-rainy season.

- ✓ Select designated waste collection areas onsite
- ✓ Use only watertight trash-hauling dumpsters onsite. Inspect dumpsters for leaks and repair any dumpster that is not watertight
- ✓ Locate containers under cover or in a secondary containment
- ✓ Collect site trash daily and remove as needed
- ✓ Make sure toxic liquid waste (used oils, solvents, and paints) and chemicals (acids, pesticides, additives, curing compounds) are not disposed of in dumpsters designated for construction debris
- ✓ Do not hose out dumpsters on the construction site. Leave dumpster cleaning to the trash hauling contractor
- ✓ Arrange for regular waste collection before containers overflow
- ✓ Storm water run-on should be prevented from contacting stored solid waste through the use of berms, dikes, or other temporary diversion structures or through the use of measures to elevate waste from site surfaces
- ✓ Store solid waste away from drainage facilities and water courses

Material Delivery and Storage. Prevent, reduce, or eliminate the discharge of pollutants from material delivery and storage to the stormwater system or watercourses by minimizing the storage of hazardous materials onsite, storing materials in a designated area, installing secondary containment, conducting regular inspections, and training employees and subcontractors.

- ✓ Construction site areas should be designated for material delivery and storage. Temporary storage areas should be located away from vehicular traffic, drainage facilities and watercourses but near the construction entrance if possible.
- ✓ An up to date inventory of materials delivered and stored onsite should be kept.
- ✓ Hazardous materials storage onsite should be minimized. Hazardous materials should be handled as infrequently as possible.
- ✓ Do not store chemicals, drums, or bagged materials directly on the ground. Place these items on a pallet and, when possible, in secondary containment.
- ✓ Through the rainy season, each temporary containment facility should be covered during non-working days, prior to, and during rain events.
- ✓ Materials should be stored in their original containers and the original product labels should be maintained in place in a legible condition. Damaged or otherwise illegible labels should be replaced immediately.
- ✓ A supply of spill clean up material should be kept near storage areas.

Vehicle and Equipment Fueling. Vehicle equipment fueling procedures and practices are designed to prevent fuel spills and leaks, and reduce or eliminate contamination of storm water.

- ✓ Use offsite-fueling stations as much as possible. These businesses are better equipped to handle fuel and spills properly. Performing this work offsite can also be economical by eliminating the need for a separate fueling area at a site.
- ✓ When fueling must take place onsite, designate an area away from drainage courses to be used. Fueling areas should be identified in the Construction SWPPP.
- ✓ Dedicated fueling areas should be protected from storm water run-on and runoff, and should be located at least 50 ft away from downstream drainage facilities and watercourses. Fueling must be performed on level-grade areas. Protect fueling areas with berms and dikes to prevent run-on, runoff and to contain spills.
- ✓ Nozzles use in vehicle and equipment fueling should be equipped with an automatic shutoff to control drips. Fueling operations should not be left unattended.
- ✓ Do not top-off fuel tanks.
- ✓ Train employees and subcontractors in proper fueling and cleanup procedures.
- ✓ Drip pans or absorbent pads should be used during vehicle and equipment fueling, unless the fueling is performed over an impermeable surface in a dedicated fueling area.
- ✓ Absorbent spill cleanup materials and spill kits should be available in fueling areas and on fueling trucks, and should be disposed of properly after use.

Vehicle and Equipment Cleaning. Cleaning BMPs eliminate or reduce the discharge of pollutants to stormwater from vehicle and equipment cleaning operations.

- ✓ Contract with an offsite or mobile commercial washing business when possible. These businesses may be better equipped to handle and dispose of the wash waters properly.
- ✓ Use phosphate-free, biodegradable soaps. Note, even phosphate-free biodegradable soaps have been shown to be toxic to fish before the soap degrades.
- ✓ All vehicles and equipment that regularly enter and leave the construction site must be cleaned offsite.
- ✓ Do not steam clean equipment on site.

- ✓ When vehicle and equipment washing and cleaning must occur onsite, and the operation cannot be located within a structure or building equipped with appropriate disposal facilities, the outside cleaning area should be:
 - Located away from storm drain inlets, drainage facilities or watercourses
 - Paved with concrete or asphalt and bermed to contain wash waters and to prevent run-on and runoff
 - Configured with a sump to allow collection and disposal of wash water
 - Prevent discharge of wash waters to storm drains or watercourses, and
 - Used only when necessary

Inspection and Maintenance.

- Inspect and verify that activity-based BMPs are in place prior to the commencement of associated activities. While activities associated with the BMP are under way, inspect weekly during the rainy season, within 48 hours after a storm event, and at two-week intervals in the non-rainy season to verify continued BMP implementation
- Inspect BMPs subject to non-stormwater discharges daily while non-stormwater discharges occur
- Monitor employees and subcontractors throughout the duration of the construction project to ensure appropriate practices are being implemented

[Appendix 1

~~Recommended Standard Notes for Erosion Control Plans.~~

~~Plans should also identify with phone numbers the person or firm responsible for the preparation of and maintenance of the erosion control plan.~~

~~Notes:~~

~~Approval of this erosion/sedimentation control (ESC) plan does not constitute an approval of permanent road or drainage design (e.g. size and location of roads, pipes, restrictors, channels, retention facilities, utilities, etc.).~~

~~The implementation of these ESC plans and the construction, maintenance, replacement, and upgrading of these ESC facilities is the responsibility of the applicant/contractor until all construction is completed and approved and vegetation/landscaping is established.~~

~~The boundaries of the clearing limits shown on this plan shall be clearly flagged in the field prior to construction. During the construction period, no disturbance beyond the flagged clearing limits shall be permitted. The flagging shall be maintained by the applicant/contractor for the duration of construction.~~

~~The ESC facilities shown on this plan must be constructed in conjunction with all clearing and grading activities, and in such a manner as to ensure that sediment and~~

~~sediment laden water do not enter the drainage system, roadways, or violate applicable water quality standards.~~

~~The ESC facilities shown on this plan are the minimum requirements for anticipated site conditions. During the construction period, these ESC facilities shall be upgraded as needed for unexpected storm events and to ensure that sediment and sediment-laden water do not leave the site.~~

~~The ESC facilities on active sites shall be inspected daily by the applicant/contractor and maintained as necessary to ensure their continued functioning.~~

~~The ESC facilities on inactive sites shall be inspected and maintained a minimum of once a month or within 48 hours following a major storm event.~~

~~At no time shall more than one foot of sediment be allowed to accumulate within a trapped catch basin. All catch basins and conveyance lines shall be cleaned prior to paving. The cleaning operation shall not flush sediment-laden water into the downstream system.~~

~~Stabilized construction entrances shall be installed at the beginning of construction and maintained for the duration of the project. Additional measures may be required to ensure that all paved areas are kept clean for the duration of the project.]~~

SECTION XXXX:

That Title 18 Appendix (CARSON CITY DEVELOPMENT STANDARDS), Division 14 (STORM DRAINAGE), Section 14.05 (Low impact development standards) is hereby amended (**bold, underlined** text is added, [~~stricken~~] text is deleted) as follows:

14.05 Low impact development standards.

1. In accordance with this section and [~~Chapter~~] **chapter** 12.20 of title 12 of CCMC, all development and redevelopment must satisfy the low impact development standards described in subsection 2.
2. All low impact development standards are set forth in the Carson City Drainage Manual, as may be amended, which is hereby adopted and incorporated by reference. A copy of the Drainage Manual may be obtained, without charge, from the Carson City Public Works Department, 3505 Butti Way, Carson City, Nevada 89701, and on the Carson City Internet website at <https://carson.org/government/departments-g-z/public-works> .
- 3. For any storm drainage improvement that is made in or on a City right-of-way, the contractor or developer who is identified on the building permit shall secure a surety bond in a coverage amount for the cost of the improvement and naming the City as obligee for the purpose of providing a warranty against any defects in workmanship or materials that are discovered within 1 year from the date on which the improvement is accepted by the City.**

SECTION XXXX:

That Title 18 Appendix (CARSON CITY DEVELOPMENT STANDARDS), Division 14 (STORM DRAINAGE), Section 14.01 (Reserved) is hereby repealed (**bold, underlined** text is added, [~~stricken~~] text is deleted) as follows:

[14.1 Reserved.]

Editor's note(s) — ~~Ord. No. 2021-3, § VIII, adopted March 18, 2021, repealed § 14.1, which pertained to drainage policy introduction and basic principles and derived from Ord. 2001-23, Development Standards.]~~

SECTION XXXX:

That Title 18 Appendix (CARSON CITY DEVELOPMENT STANDARDS), Division 14 (STORM DRAINAGE), Section 14.2 (Reserved) is hereby repealed (**bold, underlined** text is added, [~~stricken~~] text is deleted) as follows:

[14.2 Reserved.]

Editor's note(s) — ~~Ord. No. 2021-3, § VIII, adopted March 18, 2021, repealed § 14.2, which pertained to technical criteria and derived from Ord. 2001-23, Development Standards.]~~

SECTION XXXX:

That Title 18 Appendix (CARSON CITY DEVELOPMENT STANDARDS), Division 14 (STORM DRAINAGE), Section 14.3 (Reserved) is hereby repealed (**bold, underlined** text is added, [~~stricken~~] text is deleted) as follows

[14.3 Reserved.]

Editor's note(s) — ~~Ord. No. 2021-3, § VIII, adopted March 18, 2021, repealed § 14.3, which pertained to storm drain system and derived from Ord. 2001-23, Development Standards.]~~

SECTION XXXX:

That Title 18 Appendix (CARSON CITY DEVELOPMENT STANDARDS), Division 14 (STORM DRAINAGE), Section 14.4 (Reserved) is hereby repealed (**bold, underlined** text is added, [~~stricken~~] text is deleted) as follows:

[14.4 Reserved.]

Editor's note(s)—Ord. No. 2021-3, § VIII, adopted March 18, 2021, repealed § 14.4, which pertained to detention and derived from Ord. 2001-23, Development Standards.]

SECTION XXXX:

That Title 18 Appendix (CARSON CITY DEVELOPMENT STANDARDS), Division 14 (STORM DRAINAGE), Section 14.5 (Reserved) is hereby repealed (**bold, underlined** text is added, [~~stricken~~] text is deleted) as follows:

[14.5 Reserved.]

Editor's note(s)—Ord. No. 2021-3, § VIII, adopted March 18, 2021, repealed § 14.5, which pertained to trash racks and derived from Ord. 2001-23, Development Standards.]

SECTION XXXX:

That Title 18 Appendix (CARSON CITY DEVELOPMENT STANDARDS), Division 14 (STORM DRAINAGE), Section 14.6 (Reserved) is hereby repealed (**bold, underlined** text is added, [~~stricken~~] text is deleted) as follows:

[14.6 Reserved.]

Editor's note(s)—Ord. No. 2021-3, § VIII, adopted March 18, 2021, repealed § 14.6, which pertained to submittal and review process and derived from Ord. 2001-23, Development Standards.]

SECTION XXXX:

That Title 18 Appendix (CARSON CITY DEVELOPMENT STANDARDS), Division 14 (STORM DRAINAGE), Section 14.7 (Reserved) is hereby repealed (**bold, underlined** text is added, [~~stricken~~] text is deleted) as follows:

[14.7 Reserved.]

Editor's note(s)—Ord. No. 2021-3, § VIII, adopted March 18, 2021, repealed § 14.7, which pertained to drainage study information page and derived from Ord. 2001-23, Development Standards.]

SECTION XXXX:

That Title 18 Appendix (CARSON CITY DEVELOPMENT STANDARDS), Division 14 (STORM DRAINAGE), Section 14.8 (Reserved) is hereby repealed (**bold, underlined** text is added, [~~striken~~] text is deleted) as follows:

[14.8 Reserved.

Editor's note(s)—~~Ord. No. 2021-3, § VIII, adopted March 18, 2021, repealed § 14.8, which pertained to conceptual drainage study and derived from Ord. 2001-23, Development Standards.]~~

SECTION XXXX:

That Title 18 Appendix (CARSON CITY DEVELOPMENT STANDARDS), Division 14 (STORM DRAINAGE), Section 14.9 (Reserved) is hereby repealed (**bold, underlined** text is added, [~~striken~~] text is deleted) as follows:

[14.9 Reserved.

Editor's note(s)—~~Ord. No. 2021-3, § VIII, adopted March 18, 2021, repealed § 14.9, which pertained to technical drainage study and derived from Ord. 2001-23, Development Standards.]~~

SECTION XXXX:

That Title 18 Appendix (CARSON CITY DEVELOPMENT STANDARDS), Division 14 (STORM DRAINAGE), Section 14.10 (Reserved) is hereby repealed (**bold, underlined** text is added, [~~striken~~] text is deleted) as follows:

[14.10 Reserved.

Editor's note(s)—~~Ord. No. 2021-3, § VIII, adopted March 18, 2021, repealed § 14.10, which pertained to improvement plans and derived from Ord. 2001-23, Development Standards.]~~

SECTION XXXX:

That Title 18 Appendix (CARSON CITY DEVELOPMENT STANDARDS), Division 15 (WATER, SEWER, RECLAIMED WATER STANDARDS), Section 15.1

(General information) is hereby amended (**bold, underlined** text is added, ~~[stricken]~~ text is deleted) as follows:

15.1 General information.

15.1.1 Water and Sewer. Water and sewer mains shall be extended for the following:

- a. Parcel map development with a property line within ~~[four hundred feet (400')]~~ **400 feet** of an existing water or sewer main or as otherwise required in these standards. ~~[Prior to]~~ **Before** recording a parcel map, the ~~[owner/developer shall]~~ **owner or developer must** submit improvement plans to ~~[Carson City development engineering and Carson City fire department]~~ **the Engineering Division of the Department** for approval of water and sewer main extensions ~~[(the fire department approval is required for water main extensions only). The owner/developer]~~ **. The owner or developer shall construct the water and sewer mains or [provide the engineering division with] secure for the Engineering Division a suitable bond equal to one [hundred fifty percent (150%)] 150 percent of the [engineer's cost estimate prior to recording the parcel map] cost as estimated by the Engineering Division before the parcel map is recorded.**
- b. Water and sewer mains ~~[shall]~~ **must** be extended **through** the entire ~~[frontage(s)]~~ **frontage** of ~~[the]~~ **a** parcel unless **an** engineering analysis determines it is physically impossible to do so ~~[or]~~ **,** it is determined by the ~~[city engineer]~~ **City Engineer** that further extension of the main beyond the parcel can never occur ~~[or]~~ **, it is a single-family home construction located on a parcel not included within a subdivision, planned unit development or parcel map development and is currently served by an existing main,** it is not necessary for continuity of the system, or the extension of the main is to accommodate a failed well or septic system. In such cases, the length of extension ~~[shall]~~ **must** be determined by the ~~[city engineer or designee. Construction of a single family residence on a parcel not associated with a subdivision, planned unit development (PUD) or parcel map development and currently served by an existing main shall not require extension of the main(s).]~~ **City Engineer.** Construction of a ~~[single family]~~ **single-family** residence **located** on a corner lot **that is** not ~~[associated with a subdivision, PUD]~~ **included within a subdivision, a planned unit development** or parcel map development ~~[shall require]~~ **requires** extension along one ~~[(1)]~~ **one** street frontage ~~[only.]~~ **.**
- c. The ~~[utilities department]~~ **Carson City Department of Public Works** shall identify possible locations of insufficient capacity to be addressed by **the** developer's engineer. The developer ~~[shall be]~~ **is** responsible for main extensions when the design capacity of existing mains is less than that required to serve a development. Mains ~~[shall]~~ **must** be extended when existing mains are physically inaccessible to maintenance crews and equipment, as determined by the ~~[city engineer or designee.]~~ **City Engineer.**
- d. For the purposes of administering these standards for main extensions and replacements, developments are defined as follows:
 - subdivisions, ~~[PUD's,]~~ **planned unit developments,** parcel map developments;
 - new building construction;

multi-family, commercial and industrial additions or remodels which may result in an increase in the historical water usage or sewer contribution for the parcel.

e. Reclaimed water mains [~~shall not be~~] **are not** required to be extended if the parcel does not receive connection. Connection to reclaimed water mains require the developer to obtain approval from local and state agencies.

f. An individual lateral must be provide to the edge of the right-of-way for all adjacent properties that front a street where a water or sewer main is being extended unless waived by the City Engineer.

15.1.2 Reimbursement Agreements. [~~The owner/developer~~] **An owner or developer** may apply to the [~~Carson City development engineering services~~] **Engineering Division of the Department** for future reimbursement from adjacent property owners which connect to the main extension [~~per the provisions of Carson City Municipal Code (CCMC). Carson City development engineering services~~] **. The Engineering Division** shall process [~~the developer's application and, upon approval of a~~] **all applications. If a** reimbursement agreement **is approved** by the [~~board of supervisors,~~] **Board of Supervisors,** the agreement [~~shall~~] **must** be administered by the [~~engineering department.~~] **Engineering Division.**

15.1.3 Participation in Oversizing Mains. [~~When~~] **If** the oversizing of mains [~~has been~~] **is** requested by the [~~city engineer, the development shall~~] **City Engineer, the owner or developer must** participate in the installation of oversized water and sewer mains [~~as per~~] **in accordance with** the **applicable** provisions of [~~the Carson City Municipal Code.~~] **CCMC.**

15.1.4 Private water and sewer mains that are located on private property must meet the applicable requirements of the Uniform Plumbing Code and the National Fire Protection Association, as adopted by the City. Private water mains must be separated from any public main by a backflow preventer. Private sewer mains must be separated from any public main by a manhole or cleanout as approved by the City.

15.1.5 For any water or sewer main improvement that is made in or on a City right-of-way, the contractor or developer who is identified on the building permit shall secure a surety bond in a coverage amount for the cost of the improvement and naming the City as obligee for the purpose of providing a warranty against any defects in workmanship or materials that are discovered within 1 year from the date on which the improvement is accepted by the City.

SECTION XXXX:

That Title 18 Appendix (CARSON CITY DEVELOPMENT STANDARDS), Division 15 (WATER, SEWER, RECLAIMED WATER STANDARDS), Section 15.2 (Improvement plan requirements) is hereby amended (**bold, underlined** text is added, [~~stricken~~] text is deleted) as follows:

15.2 Improvement plan requirements.

15.2.1 Main Extensions and Fire Lines. Improvement plans for water, sewer and reclaimed water main extensions, public and private fire hydrant installations, and fire sprinkler line installations shall conform to the following requirements:

- a. Sewer service lateral sizes and water service line, curb and corp stop sizes for subdivision and parcel map development shall be shown by note on each plan/profile sheet.
- b. Plans shall indicate dimensions from street centerline or control line to all existing and proposed mains. All valves, hydrants, flush valve assemblies, air release valves, manholes and laterals shall be stationed and dimensioned from street centerline or control line.
- c. Plans shall indicate proposed use of meter; i.e., domestic or irrigation.
- d. Plans shall indicate whether the water service lateral shall be installed by a properly licensed contractor or by city forces.

SECTION XXXX:

That Title 18 Appendix (CARSON CITY DEVELOPMENT STANDARDS), Division 15 (WATER, SEWER, RECLAIMED WATER STANDARDS), Section 15.3 (Design requirements) is hereby amended (**bold, underlined** text is added, ~~stricken~~ text is deleted) as follows:

15.3 Design requirements.

15.3.1 Water and Reclaimed Water Design Criteria.

- a. Main Analysis. Water mains shall be analyzed to determine system capability to provide adequate flows and pressures. The analysis and calculations shall be provided to ~~[Carson City development engineering]~~ **the Development Engineering Division of the Department** for review and ~~[approval, or the applicant may request that the analysis be done by the city. The cost to the city for performing the analysis shall be charged to the developer.]~~ **approval.** Water mains shall be designed to deliver a minimum of sixty (60) psi at the meter during ~~[peak demand]~~ **Max Day Demand** periods and to provide adequate fire flow as required by the fire department. If project is an infill development where the existing system is incapable of providing sixty (60) psi, the ~~[utilities director]~~ **Director of the Carson City Department of Public Works** may waive the requirement. **Except as otherwise exempted by the City Engineer and approved by the Director of the Carson City Department of Public Works, water velocities must be maintained below 8 feet per second during all conditions of flow other than fire flow.**

Subdivisions, [~~PUD's~~] **planned unit developments** and large commercial or industrial projects having a significant impact on the city water system as determined by the [~~Carson City development engineering department shall~~] **Development Engineering Division of the Department must** provide an update of the city water model using a format that is compatible with the current [~~model, or request the city perform the analysis as described above.~~] **model.**

New construction or remodels adjacent to the existing Carson City water system where little or no additional system improvements are required; must provide a report with current date, project address (with location map), APN number, permit number, if available, comparing the required fire flow established by the building and safety department (UFC) and the "available" flow obtained by the actual fire flow data sheet, which shall be approved.

The report shall address system pressures at the project location to assure sixty (60) psi is available at all water meters during [~~peak day demands.~~] **Max Day Demands.**

Reclaimed water mains shall be analyzed to provide adequate flow and pressure at the points of service for new intended use. The analysis must consider future uses as determined by the [~~utilities department.~~] **Carson City Department of Public Works.**

- b. Main Size and Material. Mains shall be sized as required by flow calculations, however, the minimum water main diameter [~~shall be six inches (6").~~] **8 inches.**

Water mains [~~shall be PVC C-900 CL-150~~] **AWWA rated PVC 900 SDR18** unless otherwise required and approved by the [~~utilities department.~~] **Carson City Department of Public Works.** Reclaimed water mains [~~shall be PVC C-900 CL-150,~~] **must be AWWA rated PVC C-00 SDR18,** purple in color, unless otherwise required and approved by the [~~utilities department.~~] **Carson City Department of Public Works.**

- c. Standard Details. The installation of all new water and reclaimed water lines shall conform to the "Standard Details for Public Works Construction" as adopted by Carson City.
- d. Meters. Each building shall be served by a separate water service and meter unless otherwise approved by the [~~utilities department.~~] **Carson City Department of Public Works.** All meters shall be located within the street right-of-way or in a public utilities easement (P.U.E.) parallel and adjacent to the street right-of-way unless otherwise approved by the [~~city engineer.~~] **City Engineer.** Meters shall not be located within the driving surface.

Meter sizes available include $\frac{5}{8}$ " x $\frac{3}{4}$ ", 1", 1 $\frac{1}{2}$ ", 2", 3", 4", 6", and 8".

- e. Services. Services shall be located as per the standard detail titled "typical utility laterals locations," unless otherwise approved by the utilities department. Reclaimed water meter boxes shall be painted purple. All services, except those located in cul-de-sacs, shall be installed perpendicular to the main.

Service lines may be $\frac{3}{4}$ ", 1", 1 $\frac{1}{2}$ ", 2", 3", 4", 6", and 8". A 3" service requires a 4" gate valve with a 4" line.

See [~~standard details titled "Water Service Tap," "1/4" Double and Single Pit Setter," "1" Single Pit Setter," "1 1/2" to 2" Meter Set," "3" to 8" Meter Set," "Service Saddle Detail,~~

(3/4" to 2"), and "1" Dual Meter Set."] **Refer to the Carson City Standard Details for Public Works Construction for installation requirements.**

- f. Valves. Water valves on distribution mains shall be spaced at intervals not to exceed five hundred feet (500'). Reclaimed water valves shall be spaced at intervals not to exceed one thousand three hundred twenty feet (1,320'). No point within the system being designed shall require more than three (3) valve closures to discontinue service. Valves shall be located so that no more than fifteen (15) ~~[customers]~~ **services** are taken out of service at any one time. Valves shall be placed a minimum of twenty feet (20') from the end of all mains which may be extended in the future unless there is no possibility of future connections as determined by the ~~[utilities department. See standard details titled "valve detail" and "valve box detail".]~~ **Carson City Department of Public Works.**

Water valves at intersections shall be located at the ~~[curb returns.]~~ **tee or cross unless otherwise directed by the City Engineer.** Reclaimed water valves shall not be located at intersections without approval by the ~~[city engineer.]~~ **City Engineer.**

All existing valves necessary to isolate the section of main to be extended shall be shown.

- g. ~~[Flush valve assemblies.]~~ **Dead end mains.** A ~~[four inch flush valve assembly or]~~ fire hydrant is required at the end of all pressurized dead end water mains and stubs greater than ten (10) feet as per standard detail titled ~~["flush valve assembly."]~~ **"Fire Hydrant Assembly Detail." Hydrants must be designed at defined low elevation points, in the water main, to allow flushing of sediment that would settle in those low spots, which excludes short water main lowerings.**
- h. Fire hydrants. Fire hydrants within a subdivision shall be spaced as approved by the fire department. Fire hydrants and their associated valve shall be shown on the plans and constructed as per standard detail titled "fire hydrant assembly detail."
- i. Check-valves. Check-valves shall be installed on all private fire hydrant lines per standard detail titled "check-valve detail." Pressure loss associated with all check-valves shall be included in fire flow calculations.

Check-valves shall be installed on the customer's side of the right-of-way line. When a P.U.E. is parallel to the right-of-way line, the check-valve shall be installed on the customer's side of the P.U.E.

- j. Double check-valve assemblies. Double check-valve assemblies shall be installed ~~[on all private fire sprinkler lines as per standard detail titled "Detail for Double Check Valve Assemblies." Fire systems utilizing chemicals require a reduced pressure backflow assembly.]~~ **as required by the relevant provisions of chapter 445A of NAC.** Pressure loss associated with all check-valves shall be included in fire flow calculations. The assemblies shall be tested prior to certificate of occupancy and annually by a certified backflow prevention assembly tester as approved by the ~~[utilities department.]~~ **Carson City Department of Public Works.**

Double check-valve assemblies shall be installed on the customer's side of the right-of-way line. When a P.U.E. is parallel to the right-of-way line, the double check-valve assembly shall be installed on the customer's side of the P.U.E.

- k. Tapping sleeves. Tapping sleeves are required when connecting a new main to an existing main when water service cannot be discontinued. See standard detail titled "tapping sleeve detail."

The water utility division shall tap all existing water mains when the tap size is greater than two (2) inches (four (4) inches, six (6) inches, ten (10) inches, or twelve (12) inches). The plans shall indicate when a tap is to be performed by the water utility division. Plans shall include a note indicating that the contractor shall notify Carson City Water Utility, in writing, forty-eight (48) hours prior to performing hot taps, either by fax or mail. (Fax number 775-887-2164)

- l. Air-release and vacuum valves. Air-release valves are required at all high points in water mains unless adequate relief is provided and approved by the ~~[utilities department.]~~ **Carson City Department of Public Works.** See standard detail titled ~~["air release valve detail." Air release/vacuum]~~ **"Air-Release Valve Detail. Air-release or vacuum** valves are required at all high points in reclaimed water mains and shall be spaced at two thousand six hundred (2,600) feet maximum intervals, regardless of whether high points exist in the main. Provide calculations for sizing air-release/vacuum valves for review and approval by ~~[Carson City development engineering.]~~ **the Development Engineering Division of the Department.**
- m. Separations. Minimum horizontal separation between water lines and sewer, storm drain and reclaimed water lines shall be ten (10) feet. Minimum horizontal separation from all other utilities shall be five (5) feet. Minimum vertical separation shall be eighteen (18) inches unless otherwise approved by the ~~[utilities department.]~~ **Carson City Department of Public Works.** See standard detail titled "sanitary sewer and storm drain crossings."
- n. Lowering water mains. Water mains in conflict with sewer, storm drain and reclaimed water lines shall be adjusted as per standard detail titled "lowering water mains." Other means for separation, such as designing with vertical curves, shall require approval of the ~~[Carson City development engineering.]~~ **Development Engineering Division of the Department.** Provide calculations for review and approval by the ~~[Carson City development engineering.]~~ **Development Engineering Division of the Department.**
- o. Air-gap separation. Private receiving tanks require an air-gap and shall be installed as per standard detail titled ~~["installation for air-gap separation."]~~ **"Installation for Air-Gap Separation."** A backflow prevention assembly permit from the ~~[utilities department]~~ **Carson City Department of Public Works** is required prior to installation.
- p. Reduced pressure assemblies. Reduced pressure assemblies shall be per standard detail titled ~~["detail for reduced pressure principle assemblies"]~~ **"Detail for Reduced Pressure Principle Assemblies"** and are required ~~[per Table I, Type of Backflow Protection Required.]~~ **by the applicable provisions of chapter 445A of NAC.** A backflow prevention assembly permit from the ~~[utilities department]~~ **the Carson City Department of Public Works** is required prior to installation. These assemblies shall be tested annually by a certified backflow prevention assembly tester as approved by the ~~[utilities department.]~~ **Carson City Department of Public Works.**

- q. Thrust [~~blocks.~~] **and restrained joints.** Thrust blocks **or restrained joints** are required on all new water and reclaimed water main installations, public and private fire hydrants, and sprinkler line installations [~~and shall~~]. **Thrust blocks must** be constructed as shown in the standard detail titled "Thrust Block Bearing Areas." **The length of pipe required to be restrained must be properly calculated using the appropriate AWWA standard.**
- r. **Private water lines beyond a City meter, beyond a single check valve for private fire hydrant mains or beyond backflow preventer that is compliant with the requirements set forth in chapter 445A of NAC must satisfy the applicable requirements of the Uniform Plumbing Code and the National Fire Protection Association Code, and are not required to satisfy any other City standard relating to water lines.**

15.3.2 Sewer Design Criteria.

- a. Main analysis. Sewer mains shall be analyzed to determine system capability to provide capacity for the ultimate tributary population with the calculations provided to the city. Except as otherwise provided in this paragraph, a sewage collection system for any project must be sized to carry the design peak hourly flow from the entire tributary area at buildout regardless of whether the tributary area is not located within the boundaries of the project, unless deemed unnecessary by the [~~city engineer.~~] **City Engineer.** Projects with less than ten (10) dwelling units or less than two hundred (200) fixture units are exempt from this criteria. Flow generation and peaking factors shall be per recommended standards for wastewater facilities (ten (10) state standards). Sewer mains are deemed to be at capacity when the design peak flow is at depth/diameter (d/D) = 0.50, for a pipe that is 15 inches or less in diameter, and depth/diameter (d/D) = 0.75, for a pipe that is greater than fifteen (15) inches in diameter. Main analysis shall include a narrative report submitted to the [~~utilities department~~] **Carson City Department of Public Works** with maps and calculations addressing the following:
 - Area of project
 - Tributary areas outside project
 - Adjacent areas
 - Contours usually extending a minimum of three hundred (300) feet beyond the project or as needed to evaluate localized tributary areas
 - Line layout, pipe size and slope
 - Predicted average and peak flows at major junction points including flow coming from outside the project area
 - Direction of flow
 - Zoning used to predict flows
 - Special areas such as hospitals, schools, large office or industrial buildings, etc.
 - Boundaries of areas within the project which are tributary to points of major flow

Floodplains
 Scale
 Predicted flow from each area
 Peaking factors
 Cumulative flow
 Pipe capacities and depths of flow

- b. Sewer size and laterals. The minimum size for sewer mains shall be eight (8) inches and laterals shall be four (4) inches. Mains shall be sized as required by flow calculations. Sewer lines shall be PVC SDR-35 unless otherwise approved.
- c. Standard details. The installation of all new sewer lines shall conform to the "Standard Details for Public Works Construction," as adopted by Carson City.
- d. Service lateral. Each parcel shall be served by a separate sewer service lateral unless otherwise approved by the ~~[utilities department.]~~ **Carson City Department of Public Works.**

Sewer service laterals shall be located as per standard detail titled "typical utility laterals locations," unless otherwise approved by the ~~[utilities department.]~~ **Carson City Department of Public Works.** See standard details titled "sewer lateral connection detail" and "sewer service saddle detail." All service laterals, except those located in cul-de-sacs, shall be installed perpendicular to the main.

Sewer service laterals are not to be connected to manholes without prior approval of the ~~[city engineer.]~~ **City Engineer.**

- e. Design velocity. Two (2) feet per second minimum, ten (10) feet per second maximum for the design condition.
- f. Mannings formula. Mannings formula shall be used in determining slope, velocity, design flow and diameter.
- g. Slope. Minimum pipe slope shall be as required to achieve the minimum velocity of two (2) feet per second unless otherwise approved and as listed in the table below.

Size	Minimum Slope
8"	0.4%*
10"	0.25%
12"	0.19%
15"	0.14%

* Minimum slope for 8" PVC SDR-35 flexible pipe . **Shallower slopes may be approved by the City Engineer.**

The design engineer shall submit velocity and depth calculations for sewers less than minimum slope for review and approval prior to preparation of design drawings. For pipe slopes less than fourth-tenths (0.4) of a percent, the design engineer shall place the following note in a prominent location on each plan/profile sheet with slopes less than fourth-tenths (0.4) of a percent; "The contractor shall use due care in installing sewer mains." Minimum pipe slope for dead end sewers shall be five-tenths of a percent (0.5%)

unless it can be shown by calculations that the velocity in the pipe is two (2) fps or greater. Dead end sewers shall [generally] end in a [manhole. Dry sewers which shall be extended at a future date and installed without a manhole shall be certified as built for line and grade by a Nevada professional engineer or land surveyor prior to backfill. The engineer shall place a note in a prominent location on each plan/profile sheet including the as-built requirement.] **unless otherwise approved by the City Engineer.**

h. Sanitary Sewer Design Standards and Specifications—Alignment.

1. Horizontal. Sewer line less than twenty-four inches (24") in diameter shall be straight between manholes and generally parallel with the street or easement centerline whenever possible.

Sewer lines twenty-four inches (24") and larger may be considered for horizontal curvature when approved by the department.

2. Vertical. Sewer lines with vertical curvature shall not be allowed.

i. Sanitary Sewer Design Standards and Specifications—Manholes and Laterals.

Standard manholes shall be installed at the end of each line with continuing stubout; at all intersections of other sewer lines; at all changes in grade, size or alignment.

1. Spacing. Maximum spacing for manholes shall be four hundred feet (400') for all lines smaller than fifteen inches (15"), and five hundred feet (500') for lines fifteen inches (15") to twenty-four inches (24"), and six hundred feet (600') for twenty-four inches (24") and larger.
2. Increasing Size. When a smaller sewer flows into a larger sewer, the invert of the larger sewer shall be lowered sufficiently to maintain the same energy gradient. An approximate method for obtaining this result is to place the crown at the same elevation for both pipes. The average energy gradient line shall be derived from anticipated full flow capacities of the pipes.
3. Drop Manholes. A drop connection shall be provided for a sewer entering a manhole at an elevation two feet (2') or more above the manhole invert. When the difference in elevation between the incoming sewer and the manhole invert is less than two feet (2'), the manhole invert shall be filleted and channeled to prevent deposition of solids. The drop connection shall be constructed in accordance with standard detail requirements for manhole installation. Supporting calculations for hydraulic efficiency through manholes that do not meet the above requirements shall be submitted to the department for approval. Drop manholes shall be sixty inches (60") in diameter.
4. General. Manholes shall be installed at the end of all sewer mains, at all intersections of mains, and changes of grade, size, or alignment. One foot (1') stubs shall be provided at manholes for sewer mains which may be extended in the future. When extending a sewer main from an existing manhole without a stub, the existing manhole base shall be removed and replaced. Sewer mains entering manholes shall have a minimum one-tenth of a foot (0.1') of fall across the manhole and a maximum two-tenths of a foot (0.2') of fall across the manhole. Two-tenths of a foot (0.2') of fall may be exceeded when matching crowns of different pipe diameters. Manholes with the angle between the entering sewer

main and existing sewer main less than seventy-five (75) degrees shall be sixty inches (60") in diameter and maintain two-tenths of a foot (0.2') of fall.

Watertight manhole covers shall be used in designated floodplains and in locations where covers may be flooded by local runoff.

5. Dead End Sewers. Dead end sewers shall generally end in a manhole. Dry sewers which shall be extended at a future date and installed without a manhole shall be certified as-built for line and grade by a Nevada professional engineer or land surveyor prior to backfill.

Each parcel shall be served by a separate sewer service lateral unless otherwise approved by the [~~utilities department.~~] **Carson City Department of Public Works.**

- j. Separations. Separation of lines: Definitions. As used in Nevada Administrative Code (NAC), Chapter 445A, unless the context otherwise requires:

1. "Sewer main" includes:

- (a) A sewer main of a sanitary sewer, storm sewer or any other type of sewer; and
- (b) Any unidentified conduit with a diameter that exceeds six inches (6").

2. "Sewer service lateral" includes:

- (a) A sewer service lateral of a sanitary sewer, storm sewer or any other type of sewer; and
- (b) Any unidentified conduit with a diameter of not more than six inches (6").

Separation of lines: Sewer main parallel to water main or water service lateral. If a sewer main parallels a water main or water service lateral:

1. Whenever possible, the sewer main must be located lower than the water main or water service lateral.
2. Except as otherwise provided in subsection 3, the sewer main must be in a separate trench, and
 - (a) Located at least ten feet (10') away from the water main or water service lateral, as measured horizontally from the exterior walls of the pipes;
 - (b) If compliance with paragraph (a) is not practicable, located:
 - (1) At least five feet (5') away from the water main or water service lateral; as measured horizontally from the exterior walls of the pipes; and
 - (2) At least eighteen inches (18") lower than the water main or water service lateral, as measured vertically from the exterior walls of the pipes; or
 - (c) If compliance with neither paragraph (a) nor paragraph (b) is practicable, located at least six feet (6') away from the water main or water service

lateral, as measured horizontally from the exterior walls of the pipes. If the sewer main:

- (1) Is in place at the time a water project is performed, the sewer main must, except as otherwise provided in subparagraph (3), be totally encased in at least four inches (4") of cement slurry;
 - (2) Is not in place at the time a water project is performed, the sewer main must, except as otherwise provided in subparagraph (3), be constructed of PVC with joints that comply with Standard D3212 of the American Society for Testing and Materials; or
 - (3) Is part of a storm sewer and has a diameter of not less than twenty-four inches (24"), the sewer main must be installed with watertight joints that use joint sealants or joint gaskets.
3. If compliance with the requirements for separation set forth in subsection 2 are not practicable:
- (a) The water main or water service lateral must be encased in at least four inches (4") of cement slurry; and
 - (b) The sewer main must comply with the requirements of subparagraphs (1), (2) and (3) of paragraph (c) of subsection 2.

Separation of lines: Sewer service lateral parallel to water main or water service lateral. If a sewer service lateral parallels a water main or water service lateral, the sewer service lateral must be in a separate trench, and

1. Located:
 - (a) At least 12 inches lower than the water main or water service lateral, as measured vertically from the exterior walls of the pipes; and
 - (b) At least 48 inches away from the water main or water service lateral, as measured horizontally from the exterior walls of the pipes; or
2. If compliance with subsection 1 is impracticable, located in such a manner as is authorized by the health division.

Separation of lines: Sewer main crossing water main. If a sewer main crosses a water main:

1. The sewer main must be located at least 18 inches lower than the water main, as measured vertically from the exterior walls of the pipes; or
2. If compliance with subsection 1 is impracticable:
 - (a) A reasonable effort must be made to place the pipeline joints of the sewer main and water main, other than any welded joints, an equal distance from the point of crossing;
 - (b) The sewer main and water main must be:
 - (1) Located at least 6 inches apart, as measured vertically from the exterior of the pipes; and

- (2) Provided with such structural support as the supplier of water determines necessary; and
- (c) The area of crossing must be constructed in such a manner that:
 - (1) The sewer main is constructed of materials that comply with Standard Specifications for Public Works Construction and the American Water Works Association Standards for Water System Materials;
 - (2) The sewer main consists of PVC which is constructed with joints that comply with Standard D3212 of the American Society for Testing and Materials;
 - (3) The sewer main or water main is totally encased in at least 4 inches of cement slurry for a distance of at least 10 feet on each side of the point of crossing; or
 - (4) The sewer main or water main is installed in a pipe sleeve that extends, without joints, at least 10 feet on each side of the point of crossing.

Separation of lines: Sewer main crossing water service lateral.

- 1. If a sewer main crosses a water service lateral, the sewer main must be located:
 - (a) At least 18 inches lower than the water service lateral, as measured vertically from the exterior walls of the pipes; or
 - (b) If compliance with paragraph (a) is impracticable, in such a manner as is authorized by the health division.
- 2. If a water service lateral is in place at the time a sewer main is constructed and must be relocated to comply with this section, the relocation must be performed:
 - (a) With the approval of an in accordance with the procedures and standards of the supplier of water; or
 - (b) If compliance with paragraph (a) is impracticable, in such a manner as is authorized by the health division.

Separation of lines: Sewer service lateral crossing water main or water service lateral.

- 1. If a sewer service lateral crosses a water main or water service lateral, the sewer service lateral must be located:
 - (a) At least 12 inches lower than the water main or water service lateral, as measured vertically from the exterior walls of the pipes; or
 - (b) If compliance with paragraph (a) is impracticable, in such a manner as is authorized by the health division.
- 2. If a water main or water service lateral is in place at time a sewer service lateral is constructed and must be relocated to comply with this section, the relocation must be performed:

- (a) With the approval of and in accordance with the procedures and standards of the supplier of water; or
- (b) If compliance with paragraph (a) is impracticable, in such a manner as is authorized by the health division. (Added to NAC by Board of Health, eff. 2-20-97.)

Separation of lines: Lines across surface water.

1. A supplier of water shall consult with the health authority before preparing any plans for the construction of a pipeline of the public water system across any surface water, regardless of whether the crossing will be over or under the surface of the water.
2. If the pipeline will cross over the surface of the water, the pipe must be adequately supported and anchored, protected from damage and freezing, and accessible for repair and replacement.
3. Except as otherwise provided in subsection 4, if the pipeline will cross under the surface of the water, the pipe must be:
 - (a) Covered with at least 5 feet of backfill; and
 - (b) Enclosed in a pipe sleeve or encased with at least 4 inches of cement slurry.
4. If the pipeline will cross under the surface of a channel of water that is 15 feet or more wide:
 - (a) The pipe must be constructed with watertight mechanical joints that are capable of deflection.
 - (b) Isolation valves must be located at both ends of the crossing in such a manner that the length of the crossing can be isolated for testing, repair and sampling. The isolation valves must be easily accessible and must not be subject to flooding. The isolation valve closest to the source of the supply of water must be located in a manhole or valve chamber which is large enough for human access. The manhole or valve chamber must contain a permanent sampling tap and means for pressure testing the pipe.
 - (c) The pipe must be enclosed in a pipe sleeve or encased with at least 4 inches of cement slurry.

Water mains in conflict with sewer, storm drain and reclaimed water lines shall be adjusted as per standard detail titled "lowering water mains." Other means for separation shall require approval of the [~~utilities department.~~] **Carson City Department of Public Works.**

- k. Interceptor Connections. Sewer service laterals shall not be directly connected to sewer interceptors and sewer service laterals shall not be directly connected to sewer interceptor manholes without prior approval by the [~~utilities department.~~] **Carson City Department of Public Works.** A sewer interceptor is defined as any sewer main larger than 12 inches in diameter. Sewer service laterals may be connected to a parallel sewer main which is connected to an existing interceptor manhole.

- l. Inverted Siphons. The design of siphons shall not be undertaken until approved by the ~~[city engineer.]~~ **City Engineer.** The siphons shall not have less than 2 barrels, with a minimum pipe size of 8 inches, and shall be provided with the necessary appurtenances for convenient flushing and maintenance. The manholes shall have adequate clearances for rodding. Sufficient head and pipe sizes shall be designed to obtain minimum velocities of 3 feet per second for average flow. The inlet and outlet details shall be arranged so that normal flow is diverted to 1 barrel and so that either barrel may be removed from service for cleaning.
- m. Sewer Main Televising. All sewer mains shall have a television inspection prior to acceptance by the city and prior to paving, if applicable. All sewer mains and manholes shall be clear of debris prior to televising. Debris shall not be washed into existing sewer mains and shall be pumped to an approved disposal location or vacuumed. If sewer mains and manholes are not adequately cleaned prior to television inspection, the contractors shall be charged for cleaning and/or retelevising expenses incurred by the city.
- n. Well Meters. For new development only, private well water meters are required for property connected to city sewer and not connected to city water. Meter location and type shall be approved by the ~~[utilities department]~~ **Carson City Public Works Department** prior to installation.

15.3.3 Sewer Lift/Pump Stations.

- a. General Requirements. These standards apply only to those facilities to be owned and operated by the Carson City ~~[utilities department.]~~ **Department of Public Works.** The use of sewage lift stations or pump stations is allowed only where gravity flows are infeasible. The ~~[city engineer or designee]~~ **City Engineer** shall determine if a lift/pump station is to be owned and operated by the city. The design of stations to be owned and operated by the city is subject to approval by the ~~[city engineer or designee.]~~ **City Engineer.**

Special design consideration shall be given to match existing systems and equipment as determined by the ~~[utilities director or designee.]~~ **Director of the Carson City Department of Public Works.** Lift stations shall not have any areas requiring routine or preventative maintenance, or normal operations, designated as a confined space.

All stations shall generally conform to the following:

- b. Flows. The pumping system including the discharge piping and mains shall be designed for a minimum of 110% of the capacity of the tributary system leading to the station. The capacity shall be based on peak hour volumes.
- c. Pumps. No fewer than 2 pumps shall be provided. When only 2 pumps are used, each pump shall pump the capacity of the system.

For stations with more than 2 pumps, there shall be a standby pump with the capacity of the largest unit.

Pumps shall be designed to operate automatically in alternate cycles with the idle pump in each cycle to function as standby. Pumps shall be specifically designed for the conveyance of wastewater.

Pumps in a drywell/wetwell application shall be equipped with motors that are premium efficiency with TEFC enclosures; double mechanical seals with external flushing water; seal water systems shall meet [~~utilities department~~] **Carson City Department of Public Works** requirements (a standby seal water pump shall be provided).

- d. Flow Metering. The pump station shall have 1 magnetic flow meter with 4-20 MA output installed on the pressure main in a suitable water-tight vault.
- e. Piping. Drywell/wetwell piping applications shall be ductile iron with grooved or flanged joints.

Any fasteners used for joining pipes shall be stainless steel. Pump isolation valves shall be eccentric or full port plug valves. Swing check valves shall be provided on each pump discharge. The individual pump discharge shall connect into the main header horizontally to prevent grit buildup in the check valve. Sewage air relief valves are required at high points in the discharge line.

- f. Wetwell. Openings to wetwells shall be sealed to prevent the escape of gasses. All surfaces of wetwells shall be coated with a coal tar epoxy coating to prevent concrete corrosion. Steel used in wetwells shall be stainless. Wetwell sizing shall be in accordance with the Hydraulic Institute Standards, latest issue. The wetwell shall be sized for no greater than 4 pump starts per hour to prevent motor overheating. Openings between the wetwell and drywell shall be sealed gas-tight.
- g. Drywell. Drywell access shall be by straight stairs unless otherwise approved by the [~~utilities director or designee.~~] **Director of the Carson City Department of Public Works**. The drywell shall contain 2 sump pumps with 1 pump on the floor out of the sump. Each sump pump shall be capable of pumping 50 gallons per minute. The drywell layout shall allow for wastewater pump removal through a hatch at the ground level over each pump. The layout shall allow for personnel access to all sides of the installed equipment. The drywell shall contain an auxiliary space heater, station dehumidifying unit, and venting fan. Individual equipment lockouts are required for all motorized equipment.
- h. Ventilation. Ventilation shall be in accordance with the latest edition on NFPA 820, Fire Protection in Wastewater Treatment and Collection Facilities or latest code as adopted by Carson City.
- i. Flood protection. Access to all spaces, all electrical panels, and motors shall be at an elevation above or protected from a 100-year flood.
- j. Standby power. A standby generator shall be provided capable of automatically running the entire station's load if power fails due to a sensed high or low voltage on any of three (3) legs of 480 volt power. The generator shall be located in a weather-protective, sound-proofed, vandal-proof and lockable housing with access to all engine and generator components for servicing and maintenance. The generator shall be fueled by natural gas or propane with an above-ground, vandal-proof storage tank with a capacity to provide a forty-eight-hour continuous run time. The generator engine block shall be equipped with a block heater and thermostat that shall allow for instantaneous start-up at -30 degrees F. The engine shall be protected with shutdown safeguards, gauges and indicator lamps for over-temperature, low oil pressure, overspeed and

overcrank. The engine shall be equipped with an automatic battery charger, installed on the hot side of the transfer switch enabling the battery to maintain its charge when idle.

- k. Applicable design codes. The following list of codes and standards are to be followed as a minimum:

Building Code (Latest Edition as adopted by Carson City);
Plumbing Code (Latest Edition as adopted by Carson City);
Mechanical Code (Latest Edition as adopted by Carson City);
Fire Code (Latest Edition as adopted by Carson City);
National Electrical Code (Latest Edition);
NFPA Article 820 (Latest Edition);
National Fire Code (Latest Edition);
Occupational Safety and Health Standards (Latest Edition);
Hydraulic Institute Standards (Latest Edition);

Great Lakes-Upper Mississippi River Board of State and Provincial Public Health and Environmental Managers Standards for Wastewater Facilities (Latest Edition).

- l. Controls. All controls and telemetry shall be above surface grade in suitable lockable and vandal-proof housings. Wastewater pump activation shall be by float or bubbler level control.
- m. Alarms. Alarm system shall be of a radio telemetry type and shall include a sending unit at the lift station and a receiving unit at a city-designated facility. The telemetry system shall be compatible and of like type with those units presently in use at the wastewater reclamation facility or as determined by the ~~[city engineer or designee.]~~ **City Engineer.** As a minimum, the following alarms shall be provided:
- (1) High wetwell;
 - (2) Flooded drywell;
 - (3) Loss of power;
 - (4) Wetwell combustible gases;
 - (5) Loss of seal water;
 - (6) Wastewater pump failure (by check valve limit switch in addition to motor overload);
 - (7) Low level.
- n. Electrical components. In addition to the requirements of NFPA 820 and the National Electric Code, electrical enclosures shall be NEMA 4X, stainless steel out of doors and NEMA 4X fiberglass in drywells and wetwells as a minimum. Conduits and boxes located in wetwells shall be PVC coated.

- o. Land. Suitable land area for the lift station installation and operation including access shall be provided by dedication to the city.

SECTION XXXX:

That Title 18 Appendix (CARSON CITY DEVELOPMENT STANDARDS), Division 15 (WATER, SEWER, RECLAIMED WATER STANDARDS), Section 15.4 (Backflow prevention) is hereby amended (**bold, underlined** text is added, [~~stricken~~] text is deleted) as follows:

15.4 Backflow prevention.

15.4.1 Type of protection required. The type of protection that shall be provided to prevent backflow into the approved water supply shall be commensurate with the degree of hazard that exists on the consumer's premises. The type of protective assembly that shall be required (listing in an increasing level of protection) includes: double check valve assembly (DC), reduced pressure principle backflow prevention assembly (RP), and an air-gap separation (AG). The water user may choose a higher level of protection than required by the city. The minimum types of backflow protection required to protect the approved water supply, at the user's water connection are given in Section 15.14.2 of the design standards. Situations which are not covered in the table shall be evaluated on a case-by-case basis and the appropriate backflow protection shall be determined by the city.

- a. When two (2) or more services supply water from different street mains to the same building, structure, or premises through which an interstreet main flow may occur, shall have at least a standard check valve on each water service to be located adjacent to and on the property side of the respective meters. Such check valve shall not be considered adequate if backflow protection is deemed necessary to protect the mains from pollution or contamination; in such cases the installation of approved backflow assemblies at such service connections shall be required.

15.4.2 Backflow prevention assemblies. **Refer to chapter 445A of NAC.**

- a. Approved backflow prevention assemblies.
 - 1. Only backflow prevention assemblies which have been approved by the city shall be acceptable for installation by a water user connected to the city's potable water system.
 - 2. The city shall provide upon request, to any affected customer, a list of approved prevention assemblies.
- b. Backflow prevention assembly installations.
 - 1. Backflow prevention assemblies shall be installed in a manner prescribed in standard details for public works construction, as adopted by Carson City. Location of the assemblies shall be as close as practical to the user's connection. The city shall have the final authority in determining the required location of a backflow prevention assembly.

- (a) Air-gap separation (AG). The air-gap separation shall be located on the user's side of and as close to the service connection as is practical. All piping from the service connection to the receiving tank shall be above grade and be entirely visible. No water use shall be provided from any point between the service connection and the air-gap separation. The water inlet piping shall terminate a distance of at least two (2) pipe diameters of the supply inlet, but in no case less than 1 inch above the overflow rim of the receiving tank.
 - (b) Reduced pressure principle backflow preventions assembly (RP). The approved reduced pressure principle backflow prevention assembly shall be installed on the user's side of and as close to the service connection as is practical. The assembly shall be installed in accordance with standard detail for public works construction, Carson City section. The assembly shall be installed so that it is readily accessible for maintenance and testing. Water supplied from any point between the service connection and the RP assembly shall be protected in a manner approved by the city.
 - (c) Double check valve assembly (DC). The approved double check valve assembly shall be located as close as practical to the user's connection and shall be installed above grade, if possible, and in a manner where it is readily accessible for testing and maintenance. If a double check valve assembly is put below grade it must be installed in accordance with standard detail for public works construction, Carson City section. Special consideration must be given to double check valve assemblies of the "Y" type. These assemblies must be installed on their "side" with the test cocks in a vertical position so that either check valve may be removed for service without removing the assembly.
- c. Backflow prevention assembly testing and maintenance.
1. The owners of any premises on which, or on account of which, backflow prevention assemblies are installed, shall have the assemblies tested by a person who has demonstrated their competency in testing of these assemblies to the city. Backflow prevention assemblies must be tested at least annually and immediately after installation, relocation or repair. The city may require a more frequent testing schedule if it is determined to be necessary. No assembly shall be placed back in service unless it is functioning as required. A report in a form acceptable to the city must be filed with the city each time an assembly is tested, relocated, or repaired. These assemblies shall be serviced, overhauled, or replaced whenever they are found to be defective and all costs of testing, repair, and maintenance shall be borne by the water user.
 2. The city shall supply affected water users with a list of persons acceptable to the city to test backflow prevention assemblies. The city shall notify affected customers by mail when annual testing of an assembly is required and also supply users with the necessary forms which must be filled out each time an assembly is tested or repaired.
 3. Upon request the city shall test a water user's backflow prevention assembly to fulfill the requirements of this division. The water user shall be charged for the

test and any maintenance found necessary to keep the assembly in working order on the next regular water bill.

d. Backflow prevention assembly removals.

1. Approval must be obtained from the city before a backflow prevention assembly is removed, relocated, or replaced.
 - (a) Removal. The use of an assembly may be discontinued and the assembly removed from service upon presentation of sufficient evidence to the city to verify that a hazard no longer exists or is not likely to be created in the future.
 - (b) Relocations. An assembly may be relocated following confirmation by the city that the relocation shall continue to provide the required protection and satisfy installation requirements. A retest shall be required following the relocation of the assembly.
 - (c) Repair. An assembly may be removed for repair, provided the water use is either discontinued until repair is completed and the assembly is returned to service, or the service connection is equipped with other backflow protection approved by the city. A retest shall be required following the repair of the assembly.
 - (d) Replacements. An assembly may be removed and replaced provided the water use is discontinued until the replacement assembly is installed. All replacement assemblies must be approved by the city and must be commensurate with the degree of hazard involved. A retest shall be required following the replacement of the assembly.

**[Table 1
Type of backflow protection required.]**

RP	Reduced Pressure
DC	Double Check
AG	Air Gap

Degree of Hazard	Minimum Type of Backflow Prevention
1. Autopsy facilities	RP
2. Auxiliary water systems- Defined as any water supply on, or available to, a customer's premises other than an approved public water system	RP
3. Beverage bottling plants	RP
4. Breweries	RP
5. Buildings:	RP
-(A) Hotels, apartment houses, public and private buildings, or structures, where sewage pumps and/or sewage ejectors have been installed	

-(B) Any commercial structure in which the specific business activity cannot be ascertained	RP
-(C) Multi-storied buildings that use booster pumps or elevated storage tanks to distribute potable water within the premises	DC
-6. Chemical plants Any premises, served from a public water supply, where there is a facility requiring the use of water in the industrial process of manufacturing, storing, compounding or processing chemicals. This shall also include facilities where chemicals are used as additives to the water supply or in the processing of products	RP
-7. Chemically contaminated water system on any premises, served from a public water supply, where chemicals are used as additives to the water supply, or where the water supply is used for transmission or distribution of chemicals, or where chemicals are used with water in the compounds or processing of products	RP
-8. Cold storage plants	RP
-9. Convalescent homes	RP
-10. Dental clinics	RP
-11. Dry cleaning facilities	RP
-12. Dye works	RP
-13. Film processing facilities or film manufacturing plants	RP
-14. Fire protection systems that are supplied from a public water system:	DC
—(A) Low-hazard fire protection system:	
—(i) Premises where the fire system is directly supplied from a public water system and there is an unapproved auxiliary water supply on or to the premises (not interconnected)	
—(ii) Premises where the fire system is supplied from a public water system and where either elevated storage tanks or fire pumps which take suction from private reservoirs or tanks are used	DC
—(B) High hazard fire protection systems:	RP

—(i) Fire protection system is supplied from a public water system and interconnected with an unapproved auxiliary water supply	
—(ii) Fire protection system is supplied from a public water system, and contains any hazardous substance	RP
–15. Hospitals	RP
–16. Ice manufacturing plants	RP
–17. Irrigation systems:	RP
—(A) Premises or locations where facilities have been installed for pumping, injecting or spreading fertilizers, pesticides or other hazardous substances	
—(B) All other irrigation systems shall be equipped with an approved vacuum breaker installed on the discharge side of each of the last valves	
–18. Laboratories Including, but not limited to teaching institutions, biological and analytical facilities	RP
–19. Laundries (commercial)	RP
–20. Medical buildings and clinics	RP
–21. Metal manufacturing, cleaning, processing or fabricating plant	RP
–22. Morgues	RP
–23. Mortuaries	RP
–24. Food establishments	RP
–25. Oil/gas production, storage or transmission premises	RP
–26. Paper and paper products manufacturing plants	RP
–27. Plastic manufacturing, extruding and injection molding (see chemical plants)	RP
–28. Plating plants	RP
–29. Portable spray or cleaning equipment which can be connected to a public water system	AG
–30. Radioactive materials or substances Plants or facilities that process, handle or store radioactive materials or substances	RP
–31. Reclaimed water distribution systems:	AG
—(A) Premises where the public water system is used to supplement the reclaimed water system	
—(B) Premises where reclaimed water is used and there is not	RP

interconnection with the potable water system	
32. Rubber manufacturing plants-natural or synthetic	RP
33. Sand and gravel plants	RP
34. Solar heating systems-Solar collector system which contains any hazardous substance and where there is a direct makeup water connection to the public water system	RP
35. Tank trucks (see fire hydrant usage policy)	AG
36. Vehicle washing facilities	RP
37. Veterinary clinics	RP
38. Automotive shops	RP
39. Other. Any other types not specifically covered shall be covered by the latest edition of the Uniform Plumbing Code (UPC), Section 1003 which contains a detailed listing of potential cross-connections and appropriate protective devices	

~~Plants, facilities or situations which are not listed in this section shall be evaluated on a case by case basis and the appropriate type of protection shall be determined by the city.]~~

SECTION XXXX:

That Title 18 Appendix (CARSON CITY DEVELOPMENT STANDARDS), Division 15 (WATER, SEWER, RECLAIMED WATER STANDARDS), Section 15.5 (Grease interception and trash containment) is hereby amended (**bold, underlined** text is added, ~~stricken~~ text is deleted) as follows:

15.5 Grease interception and trash containment.

15.5.1 Policy and procedure for approval of grease interceptors and trash containment drain systems related to food service establishments.

15.5.2 All new food service establishments or those being remodeled are required to:

- a. Install a grease interceptor sized in accordance with the **applicable provisions of the Uniform Plumbing [Code, Appendix H, but must be a minimum of seven hundred fifty (750) gallons;] Code, as adopted by the City, but which must not in any case be less than 750 gallons notwithstanding drainage fixture units calculations.**
- b. Submit plumbing plans depicting all sewer lines discharging to or bypassing the grease interceptor; and

- c. Submit, in writing, to the environmental control authority, all calculations required by the Uniform Plumbing [~~Code, Appendix H,~~] **Code** for sizing of the interceptor.
- d. Grease interceptors must be easily accessible at all times. If the interceptor is placed in a "drive-thru" lane, it is the owner's responsibility to stop the flow of traffic during the inspection to ensure the safety of the environmental control officer. This will be a condition of the owner's commercial wastewater discharge permit.

Note: Garbage disposals are prohibited in food establishments by the Carson City Municipal Code.

15.5.3 All new food establishments are required to install a floor drain in the outside trash containment pad for clean-up purposes and must comply as follows:

- a. This drain must discharge to an approved grease interceptor;
- b. Plans must reflect proper design and grading to ensure that only the containment pad area water is captured by this floor drain;
- c. The design must ensure that surface drainage (i.e., storm water or irrigation run-off) from other areas does not discharge to this floor drain;
- d. The pad cannot exceed six hundred (600) square feet unless it is covered;
- e. Design of this drainage system must be reviewed and approved by the utilities engineering staff; and
- f. During abnormally high precipitation or flooding, it is the owner's responsibility to temporarily block this drain. This will be a condition of the owner's commercial wastewater discharge permit.
- g. It is the applicant's responsibility to ensure grading is completed per the approved plans. Corrections due to construction errors are the responsibility of the applicant and must be completed as a condition of the commercial wastewater discharge permit.

15.5.4 The applicant shall submit plans to the building department for distribution to the environmental control authority. Prior to the issuance of a building permit, the applicant shall comply with the conditions of this policy.

SECTION XXXX:

That Title 18 Appendix (CARSON CITY DEVELOPMENT STANDARDS), Division 15 (WATER, SEWER, RECLAIMED WATER STANDARDS), Section 15.6 (Sand/oil interception and containment) is hereby amended (**bold, underlined** text is added, [~~stricken~~] text is deleted) as follows

15.6 [~~Sand/oil~~] Sand or oil interception and containment.

15.6.1 Policy and procedure for approval of sand/oil interceptors and secondary containment.

The statement of this policy and procedure pertains to applicants requesting building permits regarding any business utilizing wash pads or having the potential to discharge petroleum products or excessive suspended solids to the city sewer system.

- a. It is the applicant's responsibility to ensure grading is completed per the approved plans. Corrections due to construction errors are the responsibility of the applicant and must be completed as a condition of the commercial wastewater discharge permit.

15.6.2 The applicant shall submit plans to the building department for distribution to the environmental control authority. Prior to the issuance of a building permit, the applicant shall comply with the conditions of this policy.

SECTION XXXX:

That Title 18 Appendix (CARSON CITY DEVELOPMENT STANDARDS), Division 15 (WATER, SEWER, RECLAIMED WATER STANDARDS), Section 15.7 (Pretreatment program) is hereby amended (**bold, underlined** text is added, [~~stricken~~] text is deleted) as follows:

15.7 Pretreatment program.

A "commercial wastewater discharge permit" is issued to each business which prohibits the discharge of pollutants in excess of federally approved, technically based local limits. The [~~EHD~~] **ECA** samples wastewater from these businesses to determine if they are in compliance with the permit conditions. Enforcement actions are taken when necessary in accordance with the federally approved [~~Emergency~~] **Enforcement** Response Plan and [~~Emergency Response guide.~~] **Enforcement Response Guide.** Authority for these actions are provided in [~~Carson City Municipal Code (CCMC) Chapter 12.06.~~] **chapter 12.06 of Title 12 of CCMC.**

In addition to this program is the requirement for, and enforcement of, secondary containment. Any business that stores a product, new or used, that has the potential to contaminate soil or groundwater must provide a secondary containment system that will prevent any leak or spill from adversely impacting the environment.

Grease Interceptor and Trash Containment Policy.

POLICY AND PROCEDURE FOR APPROVAL OF GREASE INTERCEPTORS AND TRASH CONTAINMENT DRAIN SYSTEMS RELATED TO FOOD SERVICE ESTABLISHMENTS

The applicant shall provide plans and calculations addressing the following:

1. All new food service establishments or those being remodeled or undergoing change of ownership are required to:
 - a. Install a grease interceptor sized in accordance with the **applicable provisions of the** Uniform Plumbing [~~Code, Appendix H, but must be a minimum of seven hundred fifty (750) gallons;~~] **Code, as adopted by the City, but which must not**

in any case be less than 750 gallons notwithstanding drainage fixture unit calculations;

- b. Submit plumbing plans depicting all sewer lines discharging to or by-passing the grease interceptor; and
- c. Submit, in writing, to the Environmental Control Authority, all calculations required by the Uniform Plumbing [~~Code, Appendix H~~] **Code** for sizing of the interceptor.
- d. Grease interceptors must be easily accessible at all times. If the interceptor is placed in a "drive-thru" lane, it is the owner's responsibility to stop the flow of traffic during the inspection to ensure the safety of the Environmental Control Officer. This will be a condition of the owner's Commercial Wastewater Discharge Permit.

NOTE: Garbage disposals are prohibited in food establishments by the Carson City Municipal Code.

- 2. All new food establishments are required to install a floor drain in the outside trash containment pad for clean-up purposes and must comply as follows:
 - a. This drain must discharge to an approved grease interceptor;
 - b. Plans must reflect proper design and grading to ensure that only the containment pad area water is captured by this floor drain;
 - c. The design must ensure that surface drainage (i.e. storm water or irrigation run-off) from other areas does not discharge to this floor drain;
 - d. The pad cannot exceed six hundred (600) square feet unless it is covered;
 - e. Design of this drainage system must be reviewed and approved by the Utilities Engineering staff; and
 - f. During abnormally high precipitation or flooding, it is the owner's responsibility to temporarily block this drain, this will be a condition of the owner's Commercial Wastewater Discharge Permit.
 - g. It is the applicant's responsibility to ensure grading is completed per the approved plans. Corrections due to construction errors are the responsibility of the applicant and must be completed as a condition of the Commercial Wastewater Discharge Permit.

The applicant shall submit plans to the Public Works Department for distribution to the Environmental Control Authority. Prior to the issuance of a building permit, the applicant shall comply with the conditions of this policy.

[~~Sand/Oil~~] Sand or Oil Interceptor and Containment Policy.

POLICY AND PROCEDURE FOR APPROVAL OF [~~SAND/OIL~~] SAND OR OIL INTERCEPTORS AND SECONDARY CONTAINMENT

This statement of policy and procedure pertains to applicants requesting building permits regarding any business utilizing wash pads or having the potential to discharge petroleum products or excessive suspended solids to the city sewer system.

1. Any business that is defined by the above statement is required to install an approved [~~sand/oil~~] **sand or oil** interceptor in accordance with the **applicable provisions of the Uniform Plumbing Code, but must be a minimum of seven hundred fifty (750) gallons.** **Code, as adopted by the City, but which must not in any case be less than 750 gallons.** It is the applicant's responsibility to provide the following:
 - a. Complete plumbing plans depicting all sewer lines discharging to or by-passing the sand/oil interceptor;
 - b. Calculations required by the Uniform Plumbing Code for sizing the interceptor must be submitted to the environmental control authority;
2. Wash pads are limited, by the Carson City Municipal Code (CCMC), to six hundred (600) square feet unless covered. It is the applicants responsibility to comply with the following:
 - a. The pad must be correctly designed and graded to ensure that only wash pad wastewater is captured and drains to the approved interceptor;
 - b. The design must ensure that surface drainage (i.e., storm water or irrigation run-off) from other areas does not discharge to the wash pad drain;
 - c. Design of this drainage system must be reviewed by the utilities engineering staff;
 - d. During abnormally high precipitation or flooding, it is the owner's responsibility to temporarily block this drain. This will be a condition of the owner's commercial wastewater discharge permit; and
 - e. It is the applicant's responsibility to ensure grading is completed per the approved plans. Corrections due to construction errors are the responsibility of the applicant and must be completed as a condition of the commercial wastewater discharge permit.
3. In accordance with the CCMC, any business that stores or accumulates any product, new or used, that has the potential to impact the sewer system or contaminate soil or groundwater, must provide secondary containment as follows:
 - a. The secondary containment must have the capacity to contain one hundred percent (100%) of the product stored within it, to include precipitation from a twenty-four (24) hour, twenty-five (25) year event;
 - b. The containment must be constructed of or protected by material that will not be degraded by product stored within it; and
 - c. The requirements for secondary containment in this policy do not exempt any business from complying with any other local, state, or federal laws or regulations governing product storage or accumulation.

The applicant shall submit plans to the public works department for distribution to the environmental control authority.

Prior to the issuance of a building permit, the applicant shall comply with the conditions of this policy.

August 11, 1998

SECTION XXXX:

That Title 18 Appendix (CARSON CITY DEVELOPMENT STANDARDS), Division 16 (WELL REQUIREMENTS AND SPECIFICATIONS), Section 16.1 (Obtaining a permit for well drilling in Carson City) is hereby amended (**bold, underlined** text is added, [~~stricken~~] text is deleted) as follows:

16.1 Obtaining a permit for well drilling in Carson City.

This information is presented to help the customer through the permit and inspection procedures for obtaining a permit to drill, redrill or recondition a well in Carson City.

The Carson City environmental health department reviews and approves applications and plot plans for well drilling, redrilling or reconditioning at 3303 Butti Way, Building #1, phone number 775-887-2190.

The applicant shall submit the following to the Carson City permit center:

1. Application for well drilling permit;
2. Three plot plans;
3. Copy of the notice of intent to drill;
4. Certificate of appropriation from the state engineer for other than a domestic well.

Upon receipt of the application, the environmental health department reviews the application and plans for compliance with city and state requirements. Upon approval, a permit is issued by the Carson City permit center. Failure to complete the plot plan and application may result in delays in issuing the permit.

The drilling of all wells must conform to the requirements of the State of Nevada Regulations for Underground Water and Wells, Chapters 534.010-534.450, inclusive, and the Carson City Municipal Code, Chapter 12.15.

Inspections shall be performed by the environmental health department and require twenty-four (24) hours advance notice. To schedule an inspection, contact the well inspector at 775-887-2190, Monday through Friday, 8:00 am—5:00 pm. Please have the permit number, address, and name and telephone of the contact person when requesting the inspection.

NOTE: Water quality testing for benchmarking purposes shall be performed by the environmental health department prior to the certification of occupancy and well final permit. Water chemistry analysis and bacterial test results obtained from the health division or the Nevada State Health Laboratory may be substituted for the test performed by the environmental health department.

Water quality certifications for conventional loan applications are performed by the environmental health department, which can be contacted by calling 775-887-2190.

Water quality testing for the owner's information or VA or FHA loan applications may be obtained from the Nevada State Health Laboratory, which can be contacted by calling 775-688-1335.

SECTION XXXX:

That Title 18 Appendix (CARSON CITY DEVELOPMENT STANDARDS), Division 16 (WELL REQUIREMENTS AND SPECIFICATIONS), Section 16.2 (Obtaining a permit for well drilling in Carson City) is hereby amended (**bold, underlined** text is added, [~~stricken~~] text is deleted) as follows:

16.2 Prohibited types of wells.

Drive point, dug and jetted wells are prohibited. (Ref NAC 534.461)

Well Drilling Permit and Plot Plan Requirements.

CARSON CITY ENVIRONMENTAL HEALTH WELL DRILLING PERMIT AND PLOT PLAN REQUIREMENTS

Permit Requirements

Notice of intent to drill, received

Certificate of Appropriation from State Engineer received for other than domestic well

Plot Plan Requirements

Assessor's parcel number

Drawing scale

North arrow

Parcel acreage

Lot line dimensions

Adjacent streets and/or easements

Existing and proposed buildings

Driveways, trees

Routing of underground water, sewer, power, phone, gas, cable TV, etc.

Dimension well from property lines and existing and proposed septic systems and replacement fields on the parcel. Dimension well from existing septic systems within one hundred fifty feet (150'). If none, so indicate, indicate if the septic system trenches are less than or greater than three feet (3') depth. One hundred fifty feet (150') separation required for a deep disposal field, one hundred feet (100') separation required for a shallow disposal field, one hundred feet (100') separation required from a septic tank, fifty feet (50') separation required from a building sewer drain.

River plains, live streams, or unlined canals on the parcel or on adjacent parcels. Include a note indicating whether or not there are river plains, live streams, or unlined canals within one-quarter (¼) mile of the well.

Well Drilling Inspection Checklist.

CARSON CITY ENVIRONMENTAL HEALTH WELL DRILLING INSPECTION CHECKLIST

Well Casing—Inspection of the location of the well, placement of casing, casing material, thickness, diameter and types of joints.

Casing must be good quality steel, free of bits and breaks, unless the driller has a waiver from the State Engineer.

Casing wall thickness (cannot be waived)

<50', minimum 0.134 or 9/64 of an inch

>50'

Casing <10", minimum 0.188 or 3/16 of an inch

Casing 10", 12", 14", 16", minimum 0.250 or ¼ of an inch

For casings >16", see specifications

Casing must be centered in drill hole to allow seal to fully surround casing.

Drill hole diameter must be at least four inches (4") greater than the diameter of the outermost casing to a depth of fifty feet (50'). Drill hole diameter must be at least four inches (4") greater than the diameter of the casing plus the diameter of the fill pipe for gravel. If a conductor casing is used, the drill hole must be at least four inches (4") greater than the conductor casing, and the annular space between the conductor casing and drill hole must be sealed.

Joints must be screwed, coupled or continuously welded and watertight.

When a well is drilled within one-quarter (¼) mile of a live stream, river or unlined canal.

No perforations in production casing allowed from ground level to one hundred (100) feet.

Well must be sealed to a depth of one hundred feet (100').

Domestic well casing is eight inches (8") maximum.

Well Seal—Inspection of seal prior to placement, during placement and after completion. Inspection of the depth of the seal, placement of the grout, seal material and thickness, and distance from surface.

Wells must be sealed with neat cement, cement grout or concrete grout from ground level to a depth of fifty feet (50') below the surface, except as noted. Dry cement in the space to be sealed is not allowed.

When using a pitless adaptor:

The seal must begin within five feet (5') of the ground surface

The casing above the seal must be backfilled with native material.

A pipe through the seal for gravel feeding must have a watertight cap.

A licensed driller must place or directly supervise the placement of the seal.

The seal must be placed:

within five (5) days after setting of the casing in one continuous mass or completed within seventy-two (72) hours

from the sealing depth upward to displace the fluid to the surface of the ground, if any fluid is above the fifty feet (50') level.

When a permanent conductor casing is used and sealed in place, a watertight seal must be provided at the surface level between the conductor casing and production casing to prevent contamination of the gravel pack conductor area. A continuously welded plate or concrete seal is acceptable.

Well Final—After receipt of the well driller's report, inspection of the elevated well cap and graded to drain away from the wellhead. Obtain one sample for water chemistry analysis and one sample for bacteria test.

Top of the well casing > twelve inches (12") above finish grade.

Water samples obtained or test results submitted.

NOTE: Any deviations from the specifications require a waiver from the State Engineer.

SECTION XXXX:

That Title 18 Appendix (CARSON CITY DEVELOPMENT STANDARDS), Division 17 (SOILS ENGINEERING REPORTS), Section 17.1 (General) is hereby amended (**bold, underlined** text is added, [~~stricken~~] text is deleted) as follows:

17.1 General.

Soils engineering reports shall comply with the requirements of this manual and the appropriate section of the Uniform Building Code. Soils engineering reports are required if one or more of the following conditions are met:

1. Grading in excess of five thousand (5,000) cubic yards
2. As required by the city due to special or unique site characteristics
3. As required by the city for hillside grading activities

SECTION XXXX:

That Title 18 Appendix (CARSON CITY DEVELOPMENT STANDARDS), Division 17 (SOILS ENGINEERING REPORTS), Section 17.2 (Soils engineering report) is hereby amended (**bold, underlined** text is added, [~~stricken~~] text is deleted) as follows:

17.2 Soils engineering report.

The soils engineering report shall include a site plan showing the location and dimensions of the property, the existing topography, proposed grading, excavations for slopes, structures, faults, building setbacks from recognized active faults, special foundation zones, locations of proposed structures, surface and subsurface drainage facilities, paved surfaces, and other pertinent features. The soils engineering report shall consider soils engineering, geologic and hydrologic conditions. It shall present recommendations including but not limited to site grading criteria, liquefaction, foundation and effects of storm drainage, and recommendations for testing and inspection. The geotechnical report shall consider all applicable and pertinent earth conditions at the site. The relationship of the site to the regional geologic framework shall be discussed.

The soils engineering report shall be prepared, signed, and wet stamped by a professional engineer licensed in the state of Nevada. The soils engineering report shall be submitted to the city prior to or concurrent with the **site** improvement plans for the development.

17.2.1 General Requirements. The soils engineering report shall consider and present the following where applicable:

1. Description of the existing site and conditions.
2. A geologic map and cross sections shall be prepared in all bedrock areas. The cross sections shall be oriented to best demonstrate site geologic structure. If desired, an additional larger scale map may be used to illustrate site geology.
3. All subsurface exploration locations shall be shown on a map that utilizes the grading plan as a base. They may also be shown on the geologic map. The report shall include a description of subsurface exploration methods.
4. All subsurface explorations shall have a descriptive log. The log shall, at a minimum, provide ground surface elevation, the depth of all samples, unified soils classification, depth to ground water (if encountered, or clearly indicate if no groundwater was encountered), all geologic measurements, soil density, and description of all encountered materials.
5. Sufficient geologic measurements taken from explorations, aerial photos of lineaments, outcrop or referenced studies shall be shown on the geologic map to define the geologic structure of the project.
6. The site earth materials and geologic structure shall be discussed.
7. Regional geology shall be discussed.
8. Rippability shall be considered.
9. Large rock disposal and handling shall be discussed.
10. Seismicity of the region and site shall be evaluated.
11. Site grading details and specifications shall be discussed.
12. Disposal of surplus materials shall be discussed.

17.2.2 Slope Stability Considerations. The soils engineering report shall, at a minimum, consider the following slope stability requirements:

1. Surface stability of slopes under saturated conditions shall be calculated for all slopes greater than ten feet (10') high.
2. All graded slopes shall be at a ratio of 2:1 (horizontal to vertical) or flatter unless steeper slopes are recommended in the soils engineering report.
3. All slopes shall have a calculated safety factor of 1.50 or greater under static conditions, and a calculated safety factor of 1.1 or greater under pseudostatic conditions.
4. The soils engineering report shall provide recommendations for control of erosion/surface deterioration for graded slopes.

5. All geologic structures (i.e., bedding, joints, fault surfaces, etc.) shall be considered in the stability analyses.
 6. Strengths utilized in the stability analyses shall be derived from laboratory tests on the material that is considered for hypothetical failure.
 7. Representative geologic cross section(s) shall be developed for all slopes that have geologic structure and are analyzed for slope stability.
 8. Recommendations for retaining methods shall be discussed.
 9. Effects of surface water and ground water shall be discussed; mitigation measures shall also be discussed.
- 17.2.3 Soils Engineering Parameters. As a minimum, the soils engineering report shall discuss and present soils engineering parameters as follows:
1. Soils engineering studies shall be based on adequate and sufficient laboratory testing which shall consist of, but not necessarily be limited to, soil compressibility; shear strength; dry density and optimum moisture content; and expansion potential.
 2. The potential for soil collapse and settlement shall be evaluated.
 3. Subsurface explorations for the soils engineering report shall be shown on a plan with a scale sufficient to describe their location.
 4. Recommendations for soil removal, soil bearing pressures, foundation design, special foundation preparation requirements, retaining wall design, slope stability (deep and surface), compaction methods and specifications, suitability of soils for use as structural fill, special site or soil limitations, subgrade preparation, and other pertinent soils conditions shall be presented.
 5. Liquefaction potential shall be considered where applicable or when required by the city.
 6. Potential soil erodibility and mitigation measures shall be discussed.
 7. Recommendations for pavement design, and test results used in design shall be discussed.
 8. Recommendations for testing during grading and construction.
- 17.2.4 Rising Water Considerations. The soils engineering report shall consider rising water potential as it affects the proposed development. Rising water is water that daylight as seepage, springs or flows at the earth's surface. It can be the result of landscape water, irrigation, seasonal changes, natural rainfall and runoff or a rising ground water table. The following items shall be considered in the soils engineering report:
1. All areas of fill over low permeability bedrock shall be evaluated for rising water potential. Recommendations for drainage for retaining structures shall be presented.
 2. Geologic boundaries (i.e., faults, formational contracts, etc.) shall be evaluated for rising water.

3. Subdrains shall be designed and specifications presented for control of rising water. They shall be shown on the improvement plans.
4. Recommendations to address pumping of fill during compaction shall be presented.
5. Recommendations to address water encountered in trenching operations.

SECTION XXXX:

That Title 18 Appendix (CARSON CITY DEVELOPMENT STANDARDS), Division 18 (EASEMENTS), Section 18.1 (Requirements) is hereby amended (**bold, underlined** text is added, [~~stricken~~] text is deleted) as follows:

18.1 Requirements.

All slope improvements, water mains, sewer mains, storm drains, [~~utilities,~~] **utilities** or storm runoff improvements [~~shall~~] **must** be installed in public rights-of-way or easements granted by the developer to the [~~city,~~] **City**. The legal description of [~~easements shall~~] **any necessary easement, including related mapping or exhibit, must** be prepared by the developer. The developer, after review and approval of the legal descriptions by the [~~city,~~] **City**, shall prepare **the** easement documents **in a form acceptable by the City** for execution by the [~~city,~~] **City**.

SECTION XXXX:

That Title 18 Appendix (CARSON CITY DEVELOPMENT STANDARDS), Division 18 (EASEMENTS), Section 18.2 (Easement size) is hereby amended (**bold, underlined** text is added, [~~stricken~~] text is deleted) as follows:

18.2 Easement size.

Required **minimum** easement sizes are shown in Table 18.1:

**Table 18.1
Requirement Easement Size**

Type of Easement	Minimum Easement Size (feet)
Underground Public Utility (gas, electric, telephone, cable television)	10 feet (along all residential road frontages)
	10 feet (along all residential road frontages)
	10 feet (along all commercial road frontages)
	10 feet (along all side and rear lot lines)
Storm Drainage (open drainage channels)	10 feet plus top width of ditch
Storm Drainage (underground conveyance)	20 feet ¹
Water Lines, Sewer Lines	20 feet ¹
Other Easements	20 feet ¹

[4] **1. Easements must be centered on applicable infrastructure such as center of pipe or the lowest point of an open channel.**

2. Final easement width [shall] must be determined by line width, required trench clearance and excavated side slopes not steeper than 2:1 horizontal to ~~[vertical.]~~ vertical or as required by OSHA 1926 Subpart A App A – Soil Classification. Alternative easement widths may be acceptable if an engineered shoring solution is provided and approved by the City Engineer.

SECTION XXXX:

That Title 18 Appendix (CARSON CITY DEVELOPMENT STANDARDS), Division 19 (IMPROVEMENT PLANS SUBMITTAL REQUIREMENTS), Section 19.1 (General) is hereby amended (**bold, underlined** text is added, ~~[stricken]~~ text is deleted) as follows:

19.1 General.

All plans submitted to the ~~[city shall]~~ **City must** be on standard 24" by 36" ~~[sheets.]~~ **sheets and electronic PDF file.** Original drawings submitted to the city shall be on three (3) mil mylar. Margins shall be one and one-half inches (1½") on the left edge and one inch (1") on the other three (3) sides. Each sheet of the plans shall have a north arrow, scale (numeric and bar), and shall carry a title block which shall contain the name of the project, owner(s), and type of design shown on the plan; the engineering firm's name, address, and telephone number; the name and stamp of the professional engineer licensed in Nevada, responsible for design, the date, sheet number and total number of sheets; and information necessary to clarify the design. The plans shall clearly indicate in plan and profile, the distinction between existing conditions and proposed improvements, and shall designate improvements, and shall designate improvements as public or private. The plans shall show adjacent property owners.

The plans shall include a revision block on each sheet with revision number, date, initials of design engineer, description of plan changes, and spaces for city approval and date. All revisions within the plans shall be referenced on the title sheet.

Approval of plans shall expire one (1) year after the date of approval unless construction has commenced. Plans shall be resubmitted for approval subject to ~~[current-]~~ **any revisions to the City** standard details ~~[and changes to existing water and sewer utilities]~~ which have occurred since original approval.

SECTION XXXX:

That Title 18 Appendix (CARSON CITY DEVELOPMENT STANDARDS), Division 19 (IMPROVEMENT PLANS SUBMITTAL REQUIREMENTS), Section 19.2

(Requirements) is hereby amended (**bold, underlined** text is added, [~~stricken~~] text is deleted) as follows:

19.2 Requirements.

All plans shall conform to city standards, and shall be sealed, signed, and dated by a professional engineer, or architect where required, licensed in Nevada, and conform to the requirements of this manual and NRS and NAC 625 & 623, respectfully.

19.2.1 Title Sheet. The first sheet shall be a title sheet and include a location map and index map with the following information:

1. Location Map:
 - a. Project location
 - b. Major cross streets
 - c. North arrow
 - d. Scale: 1' = 1000' (or as appropriate)
2. Index map:
 - a. Street configuration within the project
 - b. Lot configuration and numbers (include entire tentative tract or development)
 - c. Project boundaries
 - d. Street names
 - e. Index of sheets
 - f. North arrow
 - g. Scale: 1" = 200' (or as appropriate)
 - h. Section lines
3. Signature Blocks for:
 - a. City [~~engineer or his designee~~] **Engineer**
 - b. Fire [~~department (as required)~~] **Department, as required**
4. General Information
 - a. Basis of bearing
 - b. Benchmark

19.2.2 Utility Index. A utility index shall be required where significant amounts of infrastructure is planned, and a general overview of the whole improvements is desired. The utility index shall be a single sheet of the subdivision or development showing the general location of water, sanitary sewer and storm drain systems, identifying and numbering all manholes and structures and indicating improvements as either public or private as appropriate. The utility index shall include:

1. The location of the development in relationship to the surrounding area.

2. All properties to be serviced by the water and/or sewer system.
3. All existing and proposed water mains, sewer mains and storm drains serving the development and their respective sizes, and direction of flow.
4. All valves, fire hydrants, blowoffs, manholes, lift stations, pump stations, etc.
5. All street rights-of-way and easements.
6. All street names, lot lines and lot numbers, and property boundaries.
7. The location of all wells within the boundaries of the development.
8. Water service and sewer lateral locations.
9. Scale.
10. North arrow.

19.2.3 Right-of-Way. Right-of-way lines on both sides of all streets, the boundaries of lots fronting on both sides of all streets, drainage easements, utility easements, section lines and corners, land grant lines, slope easements, and temporary construction easements both existing and proposed shall be shown on the plans. All right-of-way and easement lines and widths shall be dimensioned and noted.

19.2.4 Topography. All pertinent topography features (existing and proposed) such as street lines, curbs, sidewalks, shoulders, location and size of sanitary sewers, storm drains, water, gas, electrical, telephone lines and other underground facilities shall be shown. Structures, houses, trees, and other flora, drainage ditches, utility poles, fire hydrants, and all other features of the area which may affect the design shall also be shown.

Where proposed improvements meet existing infrastructure facilities, the plan shall show all pertinent existing elevations, gutter grades, center line of pavement, sewer and storm drain inverts and slopes, driveway locations, etc., for a minimum distance of one hundred (100) feet from the boundary or limits of the development.

When showing existing pavement or concrete in relation to new work, shading or delineation shall be made to identify new work from existing features.

19.2.5 Stationing and Orientation. All street center lines, beginning of curves, points of compound curves, end of curves and limits of work shall be stationing on the plans. Curve data shall include; centerline radius, length of curve, delta or central angle and tangent distance. Vertical curves shall include the length of the curve, begin vertical curve and end vertical curve stations and elevations, and the K-value used (rate of vertical curvature).

A class A **survey monument , constructed** in accordance with the **City** standard details shall be constructed at all street intersections, beginning and end of horizontal curves, points of curvature, and angle points.

19.2.6 Basis-of-Bearing and Bench Marks. All Improvement Plans shall include the following:

1. The horizontal survey control and basis-of-bearing for all improvement plans shall be the Nevada State Plane Coordinated System, West Zone, Carson City

Modified, based on the North American Datum-1983/1994 (NAD 83/94). Survey control points used for the horizontal control shall be shown on the improvement plans together with the Modified State Plane Coordinate System coordinate values for these points. A basis-of-bearing statement identifying that the improvement plans are based on the Nevada state plane coordinated system, West Zone, Carson City Modified, (NAD 83/94), shall be included on the plans.

2. The vertical survey control for all improvement plans shall be based on the North American Vertical Datum-1998 (NAVD 88). Bench marks used for the vertical control shall be shown on the improvement plans together with the elevation of the bench mark(s). A bench mark statement identifying the bench mark or bench marks used for the improvement plans and that they are based on NAVD 88, shall be included on the plans.

19.2.7 Typical Section. A typical section(s) for each type of street within the area to be improved, delineating the structural features, width of right-of-way, improvement dimensions and details on both sides of all streets shall be a part of the plans.

19.2.8 Profiles and Cross Sections.

- a. Cross sections shall be included in the plans for areas of significant cutting and/or filling when required by the engineering division.
- b. A plan and profile is required for water, sewer and reclaimed water main extensions, public fire hydrant installations and private fire hydrant and fire sprinkler lines from the main to the check device. Smaller size sheets from 24" x 36" may be used for fire hydrant and fire sprinkler lines. Water, sewer, storm drain and paving design may be combined on one (1) set of plans.
- c. Scale shall be minimum of 1"=50' horizontal and 1"=5' vertical or as approved by the [~~city engineer or designee~~] **City Engineer** and in any case shall be drawn to a scale and include details as necessary to clearly show all existing conditions and work to be performed.
- d. Plans shall indicate phasing and shall include a street, utility and street index map showing the location of all water, reclaimed water or sewer mains, manholes, valves, flush valve assemblies, air release valves, fire hydrants, and pumping facilities.

19.2.9 Grading. The minimum acceptable standards for grading are presented in this section and in the Carson City Municipal Code.

Submittals are necessary to ensure that on-site drainage is adequately handled, that off-site drainage at ultimate development in accordance with the current master plan, is conveyed through the project, and that the proposed development grading plans are compatible with adjacent property topography.

This section of the manual specifies the requirements of grading plans for improvements. It includes items pertinent for the city's review and reflects established professional engineering practice for preparation of grading plans. Grading plans shall be submitted to the city for all improvements.

19.2.9.1 Grading Plan Requirements. Grading plans shall include the following as required:

1. Applicable general notes. (See Table 19.1).
2. Legend and symbols.
3. Details of typical lot drainage.
4. Reference to the soils engineering report and/or engineering geologist report.
5. The grading and drainage plan shall clearly delineate the grading of the project and shall include the following:
 - a. Location of drainage facilities.
 - b. Direction of drainage flow in each street.
 - c. Location of all existing buildings, structures, trees, cesspools, septic tanks, and wells on the property.
 - d. The location of buildings or structures or other significant features which may be impacted by the project.
 - e. All existing easements for drainage devices, roadways, and utilities with reference to the record book, page, and document number.
 - f. Accurate contours and spot elevations indicating the topography of the existing ground and structures within the limits of the improvements and the surrounding areas. Contours shall be shown beyond the property line of the site being graded to properly indicate existing drainage patterns.
 - g. Finished grades by contours and/or spot elevations indicating proposed drainage patterns and grading. Show finished grade elevations at corners of all structures, curb returns, beginning of vertical curves, ending of vertical curves, and grade breaks. Pad and finished floor elevations shall be shown for final grading plans.
 - h. The location where all cuts and fills match existing ground shall be shown. The locations shall be shown continuous and obvious.
 - i. Fill compaction and testing requirements.
 - j. Building or structure setbacks where known per approved site plan.
 - k. All drainage structures.
 - l. Location and complete details of detention basins.
 - m. Top and to be of all cut and fill slopes and setback from property boundary.
 - n. Location and complete details of subdrainage systems according to approved soils report.
 - o. Locations and reference to detail sheets for structural details of all walls, both retaining walls and free standing walls.
 - p. North arrow and scale.

19.2.10 Grading Design Criteria. Grading shall conform to Chapter 33 Appendix of the Uniform Building Code and the following requirements:

1. Minimum Gradients:

a. Soil, dirt, grass, etc.	1.0%
b. Asphalt concrete	1.0%
c. Portland cement concrete (sheet flow)	1.00%
d. Concrete gutter	0.4%

2. Design for water to flow to nearest practical street, storm drain or natural watercourse. Provisions for the mitigation of cross lot drainage (i.e., lot line swales, ditches, or other drainage measures) shall be constructed for all lots one (1) acre or less in size. Provisions to prevent surface drainage across lot lines shall be designed to convey runoff from the design storm.
3. Show design and location of all drainage structures and improvements necessary for development of the site.
4. For residential lots, edge of swales shall be three feet (3') minimum from building pad.
5. Slopes:
 - a. Slopes shall be designed with full consideration of landscaping requirements. Cut and fill slopes shall be no steeper than two (2) horizontal to one (1) vertical.
 - b. Drainage shall be directed away from the faces of cut and fill slopes or into approved drainage structures. The faces of cut and fill slopes shall also be constructed to prevent erosion. This may consist of stepping or other surface protection such as erosion control blankets, vegetation, adding soil mixtures or other means. The protection for the slopes shall be installed within fifteen (15) days after completion of the rough grading.
 - c. Recommendations in the soils report shall be incorporated into the design of slopes. Slopes to be planted shall be provided with an approved system of irrigation.
6. An air quality permit and storm water discharge permit shall be obtained by the developer or owner in accordance with the requirements of the Nevada Division of Environmental Protection.

19.2.11 Erosion Control Design Criteria.

19.2.11.1 General. Improvement plans shall show both temporary and permanent erosion control treatments. The plans shall indicate temporary erosion control treatments which are to be installed and maintained throughout construction until permanent erosion control measures are in place. The plans shall also indicate permanent erosion control treatments that are to be constructed as part of the project. In all areas of the city, except the Lake Tahoe Basin, erosion control treatments shall comply with the Conservation Commission and Nevada Division of Environmental Protection "Handbook of Best Management Practices." In the Lake Tahoe Basin, erosion control

treatments shall comply with the Tahoe Regional Planning Agency "Handbook of Best Management Practices."

19.2.11.2 Temporary Erosion Control Standards. Temporary erosion control treatments shall be shown on the improvements plans. Temporary erosion control treatments shall be installed within fifteen (15) days from the start of land disturbances activities, and shall provide for the following:

1. Temporary soil stabilization measures, such as erosion control blankets, shall be installed and maintained on graded slopes graded at 10:1 or steeper until permanent erosion control treatments are in place.
2. Temporary desilting facilities shall be provided at all drainage structure inlets and prior to discharge which leaves the area which is disturbed by the project, or enters a drainage, stream, creek, lake or waterway. Desilting facilities shall be designed for a twenty-five (25) year peak storm intensity. They shall be shown and detailed on the plans, and shall indicate the desilting facility volume based on gradient, inflow, and nature of soils. The plans shall indicate the size of desilting basin outlet pipe and outlet velocity. Outlet conditions from the desilting facilities shall not exceed downstream limitations. All desilting facilities shall have an overflow which is designed to safely pass one and one-half (1½) times the twenty-five (25) year peak discharge.
3. Placement of devices to reduce erosion damage (i.e., temporary berm, check dams, hay or straw erosion checks, inlet sediment traps, etc.) within the area disturbed by the project shall be shown on the plans. Approved stockpile locations for materials shall also be indicated on the plans.
4. A construction entrance shall be installed prior to commencement of grading. Location of the entrance may be adjusted by the contractor to facilitate grading operations. All construction traffic which enters an existing paved road shall cross the construction entrance. The construction entrance shall consist of a bed of nominal two-inch (2") to four-inch (4") gravel no smaller than fifteen feet (15') wide, twenty feet (20') long and twelve inches (12") deep. The construction entrance shall be removed prior to placing base for paving.
5. The following notes shall be placed on the improvement plans:
 - a. In case of emergency call _____
 - b. A standby crew for emergency work shall be available at all times. Necessary materials shall be available on-site and stockpiled at approved locations to facilitate rapid construction of temporary devices or to repair damaged erosion control measures.
 - c. After a rainstorm, all silt and debris shall be removed from check berms and desilting facilities. Graded slope surface protection measures damaged during the rainstorm shall also be repaired.
 - d. Fill slopes at the project perimeter must drain away from the top of the slope at the conclusion of each working day.

- e. A six foot (6') high perimeter fence or a twenty-four (24) hour guard shall be posted on the site whenever the depth of water in a facility exceeds eighteen inches (18").

19.2.11.3 Permanent Erosion Control Standards. The improvement plans shall incorporate facilities, structures, and treatments necessary to prevent erosion after completion of the project. Permanent erosion control treatments are required on all slopes steeper than ~~[40:1]~~ **3:1** (horizontal to vertical). Mechanical or planted permanent slope stabilization may be used for permanent treatment.

Mechanical slope stabilization that consists of rock rip rap shall have a minimum layer thickness of twelve inches (12") and seventy-five percent (75%) of the rock shall be eight inches (8") or greater in diameter.

Planted slope stabilization shall consist of an erosion control blanket and ground cover plants or seeding.

Where required to establish vegetation, slopes to be planted shall also be irrigated with an electrically controlled automatic watering system designed to cover all portions of the slope. A minimum of head to head coverage shall be required. The irrigation system shall be installed with an approved backflow device. All planted slopes shall be irrigated by the developer until established as approved by the city.

Landscaping, planting, and irrigation plans shall be submitted with the improvement plans for slopes which are planted and/or irrigated. Landscape and irrigation plans shall be prepared and submitted in accordance with the requirements of the city code.

19.2.12 Site Drainage. Drawings which show site drainage shall be included in the improvement plans. Refer to division 14, Storm Drainage, for drainage plan requirements.

19.2.13 Plan and Profile Sheets. Plan and profile sheets shall have the same horizontal and vertical scale wherever possible. Plan and profile sheets shall have a minimum scale of 1" = 5' vertical and 1" = 40' horizontal. A scale bar shall be included on each sheet.

19.2.13.1 Streets and Access Roads. Plan and profile sheets for streets and access roads shall include the following as a minimum:

1. Name of Street.
2. Plan section: Show monuments, right-of-way width, improvements, traffic control devices, intersecting streets, center line stationing, horizontal curve data and stationing.
3. Profile section: Show existing and proposed grades along center line including tangency slopes, vertical curve elevations and data (including finished grade elevations at 25 foot intervals on vertical curves), and the station and elevations of intersecting streets. Show existing facilities.

19.2.13.2 Storm Drains. Refer to ~~[division 14, Storm Drainage,]~~ **Division 14** for storm drainage plan requirements.

19.2.13.3 Sanitary Sewers. Refer to ~~[division 15, Sewer Systems,]~~ **Division 15** for sanitary sewer plan requirements.

19.2.13.4 Water and Reclaimed Water Systems. In addition to other requirements of this division of the manual, such as the title sheet, utility index, right-of-way, topography, stationing and orientation, bench marks, details, and grading and drainage plans, improvements plans for water system (water lines, wells, treatment facilities, pumping facilities, storage tanks, buildings and appurtenant facilities) shall include the following as a minimum:

1. Plan and profile sheets for water lines which clearly show all existing conditions and work to be performed.
2. Phasing of Improvements.
3. The location and stationing of all water, reclaimed water or sewer mains, manholes, valves, flush valve assemblies, air release valves, vacuum valves, fire hydrants, pumping facilities, wells, and storage tanks.
4. Drawings and details necessary to describe and clarify the improvements. Relying on future shop or vendor drawings and submittals shall not be acceptable or adequate for city review of the improvement plans.

19.2.13.5 Landscaping. Refer to [~~division 3, Landscaping Design,~~] **Division 3** for landscape plan requirements.

19.2.13.6 Details. Standards details to be used on the project shall be shown on the plans. Additional details as necessary for clarification of the improvements shall also be shown. Provide necessary general notes, including the following note on the plans:

All construction shall conform to the [~~standard specifications for public works construction~~] **Standard Specifications for Public Works Construction** and Carson City standards.

SECTION XXXX:

That Title 18 Appendix (CARSON CITY DEVELOPMENT STANDARDS), Division 19 (IMPROVEMENT PLANS SUBMITTAL REQUIREMENTS), Section 19.3 (Permit requirements) is hereby amended (**bold, underlined** text is added, [~~stricken~~] text is deleted) as follows:

19.3 Permit requirements.

Refer to [~~the Carson City development code~~] Division 20 for permit requirements and fees.

SECTION XXXX:

That Title 18 Appendix (CARSON CITY DEVELOPMENT STANDARDS), Division 19 (IMPROVEMENT PLANS SUBMITTAL REQUIREMENTS), Section 19.4 (Changes in plans) is hereby amended (**bold, underlined** text is added, [~~stricken~~] text is deleted) as follows:

19.4 Changes in plans.

No changes in the design shall be permitted after the plans have been approved unless written approval is given by the city. Plans so changed shall be resubmitted to the city for review. Changes made in the design without approval by the city may result in revocation of the construction permit (or other city-issued permit) and refusal by the city to accept the improvements.

If, during construction, changes in the plans are required due to field conditions, such changes shall be approved by the city in writing, and the changes noted on the record drawings.

SECTION XXXX:

That Title 18 Appendix (CARSON CITY DEVELOPMENT STANDARDS), Division 19 (IMPROVEMENT PLANS SUBMITTAL REQUIREMENTS), Section 19.5 (GIS standards) is hereby amended (**bold, underlined** text is added, [~~stricken~~] text is deleted) as follows:

19.5 [~~GIS standards.~~] **Standards for digital submittal.**

All plan information [~~shall~~] **must** be submitted in digital format **using the online permit submittal portal or** on [~~a 3.5 inch floppy disk, CD, or~~] other media **and in a format that is approved by the [city.] City.** All data shall be submitted in conformance with the above requirements and shall be submitted on separate drawing [~~layers, i.e., water, sewer, storm drainage, buildings.~~] **layers.**

Table 19.1
Grading Plan General Notes

1. All work shall be done in accordance with the Uniform Building Code, OSHA requirements for excavation, and special requirements of the permit. Violations shall result in the stoppage of all work until the violation is corrected.
2. No work shall be started without first notifying the city inspector at 775-887-2310 at least 1 working day before work is commenced.
3. Slopes shall be no steeper than 2 horizontal to 1 vertical, or as determined by the soils engineer and approved by the city.
4. Fills shall be placed in accordance with the requirements of the "standard specifications for public works construction" and the Carson City Municipal Code Hillside Ordinance (when applicable).
5. The engineer of record shall provide the city with copies of all test results on a weekly basis and a bound report of the test results and inspection reports, arranged in chronological order, at the completion of the project. The engineer of record shall provide the city with an opinion regarding the construction similar to the following:

Engineer's Opinion

I hereby certify that I am a licensed engineer in the state of Nevada. To the best of my knowledge, information and belief, the project was constructed, in general conformance with the plans and specifications, and in my professional opinion, is in compliance with applicable laws, codes and ordinances.

6. Fill areas shall be cleared of all vegetation and debris, scarified, and be approved by the engineer of record prior to the placing of fill.
7. Protective measures and temporary drainage provisions shall be used to protect adjoining properties during construction of improvements.
8. Dust shall be controlled by the contractor to the satisfaction of the city and in accordance with the air quality permit from the Nevada Division of Environmental Protection when required.
9. All streets shall be maintained free of dust and mud caused by grading operations. All operations shall comply with the requirements of the stormwater discharge permit from the Nevada Division of Environmental Protection.
10. All cesspools, septic tanks, etc., to be abandoned shall be filled or removed in accordance with the state of Nevada standards and certified by the engineer of record.
11. Existing wells to be abandoned shall be capped in accordance with the state of Nevada Division of Water Resources regulations for water well and related drilling.
12. The developer's engineer or surveyor shall set grade stakes for all drainage devices and the contractor shall obtain inspection before placing concrete.
13. Finished grading shall be completed and approved, and slope planting and irrigation systems installed before issuance of a certificate of occupancy.
14. No rock or similar material greater than 6 inches in diameter shall be placed in the fill unless recommendations for such placement have been submitted by the soils engineer in advance and approved by the city.
15. The soils engineer shall approve all grading including compaction requirements and the stability of slopes created, existing or remaining.
16. In the vent of changes arising during construction, the developer shall be responsible for determining an acceptable solution and revising the plans for review and approval by the city. No changes in the design shall be permitted unless written approval is given by the city.
- 17. Best management practices must be incorporated into construction documents and specifications to reduce the spread of noxious weeds, as that term is defined by NRS 555.005. For additional information concerning best management practices related to the reduction of noxious weeds, contact the Carson City Department of Parks, Recreation and Open Space.**
17. Erosion Control:
 - a. In case of emergency call .
 - b. A standby crew for emergency work shall be available at all times. Necessary materials shall be available on-site and stockpiled at approved locations to facilitate rapid construction of temporary devices or to repair damaged erosion control measures.
 - c. After a rainstorm, all silt and debris shall be removed from check berms and desilting facilities. Graded slope surface protection measures damaged during the rainstorm shall also be repaired.
 - d. Fill slopes at the project perimeter must drain away from the top of the slope at the conclusion of each working day.
 - e. A 6-foot high perimeter fence or a 24 hour guard shall be posted on the site whenever the depth of water in a facility exceeds 18 inches.

SECTION XXXX:

That Title 18 Appendix (CARSON CITY DEVELOPMENT STANDARDS), Division 19 (IMPROVEMENT PLANS SUBMITTAL REQUIREMENTS), Section 19.6 (Plan submittal, permit and construction procedures) is hereby amended (**bold, underlined** text is added, [~~stricken~~] text is deleted) as follows:

19.6 Plan submittal, permit and construction procedures.

19.6.1 Plan Review Procedures.

- a. Plans shall be submitted to the engineering department along with a completed application for a permit.
- b. Wet stamped sets of prints shall be submitted for review per the state of Nevada guidelines. The [~~Carson City development engineering and fire departments~~] **Development Engineering Division of the Department and the Fire Department** shall review the submittal concurrently and shall prepare any comments to be addressed by the design engineer. Upon addressing all comments and requirements from the city, plans shall be resubmitted to [~~Carson City development engineering~~] **Development Engineering Division** for final review and approval. The design engineer shall include any redlines and an engineer's cost estimate with the submittal. Upon obtaining approval from each department and the required city signatures on the original cover sheet, the design engineer shall furnish reproducible and wet stamped prints.
- c. Plans for water or sewer service laterals relating to a building permit shall be submitted to [~~Carson City development engineering. Carson City development engineering~~] **the Development Engineering Division which** shall review the plans and shall prepare any comments to be addressed by the designer. Upon addressing the comments and requirements of [~~Carson City development engineering,~~] **the Development Engineering Division,** the designer shall submit corrected prints (wet stamped if prepared by a registered professional) and any redlines to [~~Carson City development engineering~~] **the Development Engineering Division** for final review and approval. Upon obtaining approval from each department and the required city signatures on the original plan, the designer shall furnish reproducible and prints (wet stamped if prepared by a registered professional).

19.6.2 Plan Revisions. Modifications to the approved plans requires review and approval by [~~Carson City development engineering.~~] **the Development Engineering Division.** For clarity, all revisions shall be identified with a Delta symbol, date of change, description of change, and the name or initials of the person making the changes. Revisions of the same date shall have the same Delta symbol letter or number. The revised areas shall be clouded on the drawings and tagged with the corresponding Delta symbol. Provide an approval block for signature and date for the engineering department. Revisions require approval by [~~Carson City development engineering~~] **the Development Engineering Division** prior to construction.

19.6.3 Final Inspection Procedures.

- a. Upon completion of all construction related to the above and prior to final acceptance, one set of record drawings prints prepared by an engineer or surveyor registered in the state of Nevada shall be supplied by the owner/developer along with a written request for a final inspection to [~~Carson City development engineering.~~] **the Development Engineering Division.**
- b. The final inspection shall be performed and a correction punch list shall be prepared. Upon completion of any punch list items addressed by the final inspection and receipt of reproducible record drawings by [~~Carson City development engineering.~~] **the Development Engineering Division,** the city shall accept the utilities improvements for maintenance purposes.

19.6.4 Record Drawings.

- a. Record drawings submitted to [~~Carson City development engineering.~~] **the Development Engineering Division** shall be accompanied by a transmittal letter which identifies the development by name, address, A.P.N., and the reason for the submittal.
- b. Reproducible record drawings [~~shall be 3 mil (minimum) mylar.~~] **must be 1 electronic CAD file and 1 electronic PDF file.**
- c. Record drawings shall be prepared and signed by a Nevada registered engineer or surveyor and shall include the following:
 - (1) Centerline stationing and dimensions from street centerline or easement line for all sewer manholes and lift stations.
 - (2) Centerline stationing and dimensions from street centerline or easement line for all water and reclaimed water valves, hydrants, meter boxes, flush valve assemblies, air release valves, check valves, booster pump stations and pressure reducing stations.
 - (3) Stationing and dimensions for all private fire hydrant and sprinkler line installations are required from the main to the check valves only.
 - (4) Operation and maintenance information and dimensions for all specialty items such as pressure reducing valve stations, water tanks, altitude valves, booster pump stations, and lift stations.
 - (5) Information received from the contractor and/or city inspectors.
 - (6) The engineer or surveyor shall place a certification on the drawing stating that the record drawings accurately reflect items (1) through (5) above, to the best of their knowledge and belief.

19.6.5 Maintenance Bond. A maintenance bond that fully complies with the provisions of the subdivision agreement, PUD agreement or parcel map agreement shall be submitted prior to final acceptance.

19.6.6 NDOT Permits. The Nevada Department of Transportation requires that NDOT permits for water and sewer main installations be in the name of the Carson City. The following are procedures for NDOT permits:

- a. The developer or their agent shall prepare the application for signature by the engineering department. A traffic control plan as required by NDOT is required prior to the city signing the application.
- b. The following information is required on each application:
 - (1) Project name and street address.
 - (2) Name, address, phone number, and contact of the developer responsible for the installation.
 - (3) Name, address, phone number, and project engineer responsible for the design.
- c. The developer or their agent is responsible for all submittals to NDOT, including the application, traffic control plan and construction plans.

~~[19.6.7 Action by the Board of Supervisors. All actions of the city engineer pursuant to the provisions of chapters 12.01, 12.05, 12.06, 12.13 and 12.14 of the Carson City Municipal Code and these standards regarding water, sewer and reclaimed water extensions, replacements, participation, reimbursement, design standards and improvement plans shall be reviewable by the board, either upon its own motion or upon the request of any person who has been refused a permit or believes that he has been aggrieved. The action of the board on all reviews shall be binding upon the utilities department.]~~

SECTION XXXX:

That Title 18 Appendix (CARSON CITY DEVELOPMENT STANDARDS), Division 20 (PERMIT PROCESSING AND FINANCIAL SECURITY REQUIREMENTS), Section 20.1 (Improvement required) is hereby amended (**bold, underlined** text is added, [~~stricken~~] text is deleted) as follows:

20.1 Improvement required.

20.1.1 As a condition precedent to the acceptance of any easements offered for dedication to the public, and prior to the approval of the final map of the subdivision, the subdivider shall agree to improve at his own expense, and within a stated time, all land so dedicated with such improvements as set forth in this division, and the final map of any such subdivision shall not be approved until either such features have been improved as provided herein, or the subdivider has executed an agreement to so improve such features as secured by a bond or cash deposit.

20.1.2 Trunk line sewers, other improvements not solely for the benefit of the subject subdivision, and full improvement of those routes shown on the "plan of streets and highways" shall not be required, unless included within the subdivider's agreement.

However, the subdivider shall be held to his proportion of all these improvements. The amount of said fair participation shall be determined by the [~~board.~~] **Board of Supervisors.**

SECTION XXXX:

That Title 18 Appendix (CARSON CITY DEVELOPMENT STANDARDS), Division 20 (PERMIT PROCESSING AND FINANCIAL SECURITY REQUIREMENTS), Section 20.2 (Water supply system) is hereby amended (**bold, underlined** text is added, [~~stricken~~] text is deleted) as follows:

20.2 Water supply system.

20.2.1 When the tentative map indicates that the proposed water supply for any lot in the subdivision comes from a source other than located upon such lot, the subdivider shall install or cause to be installed the water supply and distribution system needed to supply domestic water to all of such lots in accordance with standards herein set forth and including a fire system if required by the [~~Carson City fire chief.~~] **Fire Chief.**

20.2.2 The final map shall not be approved until the [~~city engineer~~] **City Engineer** certifies that the design of the water supply and distribution system conforms to the standards set forth and to sound engineering practices; nor until such system has either been installed and approved, or the subdivider has executed an agreement to install such system secured by a bond or cash deposit; nor until the subdivider submits written evidence that some utility or public agency is willing to maintain and operate the sewage collection and disposal system on completion.

SECTION XXXX:

That Title 18 Appendix (CARSON CITY DEVELOPMENT STANDARDS), Division 20 (PERMIT PROCESSING AND FINANCIAL SECURITY REQUIREMENTS), Section 20.3 (Subdivider's bond) is hereby amended (**bold, underlined** text is added, [~~stricken~~] text is deleted) as follows:

20.3 Subdivider's bond.

20.3.1 If at the time the final map or parcel map is considered for approval, and any of the public improvements required therein have not been completed, the subdivider shall either: (1) complete such improvements prior to the recording of the map, or (2) enter into an improvement agreement with the city to complete such improvements, prior to the date fixed by the [~~city engineer~~] **City Engineer** and specified in the improvement agreement, which shall not exceed 18 months.

20.3.2 A subdivider may enter into an improvement agreement only if 1 or more of the following forms of security, as defined by this division, is delivered to or arranged with

Carson City for an amount not less than 150 percent of either the approved engineer's estimate of the cost of the improvements covered by the improvement agreement, or the average of the bids of 3 properly licensed contractors to complete the improvements covered by the improvement agreement submitted to the city if the bids are reasonable and complete:

- a. Cash;
- b. A certificate of deposit;
- c. ~~[A deed of trust, together with an appraisal of the subject property prepared by a Member of the Appraisal Institute (MAI) appraiser, a title report and a policy of title insurance issued by a person authorized to issue title insurance under Chapter 692.A.022 of the NRS;~~
- d. ~~A lender's set-aside agreement;~~
- e.] A letter of credit;
- f. A surety bond;
- ~~[g. A trilateral agreement.]~~

20.3.3 All forms of security listed above must be in a form approved by Carson City, and it is the responsibility of a subdivider to submit to Carson City upon request, proof of the existence of any license or permit required by this division of a person issuing a security device or participating in a security agreement.

20.3.4 A subdivider may substitute 1 form of security permitted by this division for another form of security permitted by this division.

20.3.5 The improvement agreement shall allow for proportionate releases of surety. These releases shall be directly related to the proportional amount of the improvements that have been constructed and accepted. The engineer's estimate and the amount of required surety may be adjusted annually for inflation as necessary at the direction of the city engineer.

20.3.6 Once the city has accepted 100 percent of the subject improvements, 90 percent of the surety held by the city, will be released. 10 percent of the original surety will be retained by the city (a substitute maintenance surety may be posted that is equal to 10 percent of the original surety), to secure the developer's obligation to repair defects in workmanship and materials which appear in the improvements within 1 year of acceptance by the city.

20.3.7 Improvement agreements may provide for the final inspection and acceptance of stages of the work and the release of portions of the security for the stages of the work completed. The releases shall be approved in the manner set forth by written policies of the department which are approved by, and may only be changed through resolutions adopted by the board.

20.3.8 In the event of a default and a foreclosure by the city upon the security instrument, the city or its authorized agent shall complete the improvements set forth in the improvement agreement within 18 months of the time the full amount of the security is obtained by the city, unless delays caused by circumstances beyond the control of the city prevent their completion. In the event of such a delay, the city shall complete the improvements as soon as possible.

SECTION XXXX:

That Title 18 Appendix (CARSON CITY DEVELOPMENT STANDARDS), Division 20 (PERMIT PROCESSING AND FINANCIAL SECURITY REQUIREMENTS), Section 20.4 (Surveyor's bond) is hereby amended (**bold, underlined** text is added, [~~stricken~~] text is deleted) as follows:

20.4 Surveyor's bond.

20.4.1 A surveyor's bond shall be posted by either: (1) the surveyor whose name appears on the plat map, or (2) the subdivider, to [~~insure~~] **ensure** that monuments as herein required shall be set within a maximum period of one (1) year after the recording of the map.

SECTION XXXX:

That Title 18 Appendix (CARSON CITY DEVELOPMENT STANDARDS), Division 20 (PERMIT PROCESSING AND FINANCIAL SECURITY REQUIREMENTS), Section 20.5 (Engineering plan review, inspection, and testing fees) is hereby amended (**bold, underlined** text is added, [~~stricken~~] text is deleted) as follows:

20.5 Engineering plan review, inspection, and testing fees.

20.5.1 Before commencing any work regulated by these standards, the person requesting to perform such work **must pay to the City all required fees as set forth in the fee schedule adopted by the City, a copy of which may be obtained in person from the Carson City Department of Public Works, located at 3505 Butti Way, Carson City, NV 89701, or on the following Internet website: <https://www.carson.org/government/departments-g-z/public-works/utility-billing-water-sewer>**. [~~shall deposit with the city fees, as set below.~~

1. ~~The following fees must be paid to Carson City at the time an application for a permit is filed with the city.~~

~~Plan Check Fee:~~

Plan check fee for any construction which requires a permit (except grading permit)	\$120.00 base + \$65.00/hr over the 1st hour of plan review
Grading permit only	Grading plan review fees per Title 15, Buildings and Construction, Chapter 15.05, Building Code, Section 15.05.010 Adoption of the International Building Code, Appendices and Amendments, Part 108.2 Schedule of Fees of the International Building Code.

2. ~~The following inspection fees must be paid to Carson City at the time the permit is issued.~~

A.— Grading Permit. Grading permit fees per Title 15, Buildings and Construction, Chapter 15.05, Building Code, Section 15.05.010 Adoption of the International Building Code, Appendices and Amendments, Part 108.2 Schedule of Fees of the International Building Code.

B.— Concrete, Asphalt Work.

Concrete curb or gutter (lineal feet)	\$120.00 + \$0.25/l.f. over 100 feet
Concrete valley gutter	\$120.00 + \$0.25/l.f. over 100 feet
Sidewalks (square feet)	\$120.00 + \$0.10/sq. ft. over 200 feet
Driveway approaches	\$120.00 each

D.— Street, Parking Lot Paving.

Area of paving (square feet)	\$120.00 + \$0.01/sq. ft. over 10,000 sq. ft.
------------------------------	---

3.— Pavement Patching Fees. The following schedule of fees will be charged for all patching of paved surfaces restored by the city in addition to any other fee required by this section. The city engineer will have the sole discretion whether to allow pavement patching to be performed by city forces or whether to require the developer or franchisee to arrange and pay a licensed contractor to restore paved surfaces in accordance with city specifications.

Area to be patched (square feet)	\$120.00 + \$3.91/sq. ft. over the first 25 sq. ft.
----------------------------------	---

4.— Testing Fees. In addition to the plan check and inspection fees described above, the following testing fees shall be collect at the time of permit issuance.

Water and Sewer Line Tests.

Pressure test	\$35.00
B.T. test	\$35.00
Chlorine test	\$35.00
Sewer pressure test per manhole	\$20.00
Sewer video inspection (lineal foot)	\$1.00/l.f.

]

SECTION XXXX:

That Title 18 Appendix (CARSON CITY DEVELOPMENT STANDARDS), Division 21 (CONSTRUCTION OF IMPROVEMENTS INSPECTION & TESTING REQUIREMENT REPORTS), Section 21.1 (Introduction) is hereby amended (**bold, underlined** text is added, [~~striken~~] text is deleted) as follows:

21.1 Introduction.

This [~~manual has been prepared by development services of the Carson City engineering department in order to set forth the~~] **sets forth** requirements for **the** testing and inspection of infrastructure improvements constructed within Carson City. This [~~procedural manual does~~]

Division does not include **provisions for the** inspection and testing of structures as required by the Uniform Building Code which is administered by building and safety.

The owner/developer is responsible for providing inspection and testing services for all permitted work covered by this document. Listed below are the options available to the owner/developer for providing these services. Other options may be available but must be approved in advance by development engineering.

- a. Owner/Developer Inspection and Testing. Owner/developer contracts with an inspection and testing firm(s) to perform all required inspections and testing as set forth herein.
- b. Carson City Limited Inspection with Owner/developer Inspection and Testing. Carson City performs certain inspections and owner/developer contracts with a testing firm to perform all other inspection and the required testing as set forth herein. An example is the situation where Carson City staff would inspect pipe and fittings, and the owner/developer's inspection and testing firm would perform testing for the backfilling, and other inspection and testing such as pipe testing and trench patching, etc.
- c. Owner/Builder Minor Installation or Repair. Carson City would provide inspection and/or testing services for an owner/builder constructing a single family home or for an owner performing minor installations or repairs on a residential or commercial facility. The owner will be responsible for all costs associated with city-provided inspection and/or testing services.

It is the responsibility of the owner/developer to select the inspection and testing option prior to issuance of a permit. The owner/developer may indicate their choice of options on the permit application, but in no case will permits be prepared for issuance without the selection of one option. The option selected by the [~~owner/developer is final and will~~] **owner or developer** may not be changed at a later date unless approved by the [city:] **City**.

SECTION XXXX:

That Title 18 Appendix (CARSON CITY DEVELOPMENT STANDARDS), Division 21 (CONSTRUCTION OF IMPROVEMENTS INSPECTION & TESTING REQUIREMENT REPORTS), Section 21.2 (Definitions) is hereby amended (**bold, underlined** text is added, [~~stricken~~] text is deleted) as follows:

21.2 Definitions.

Inspection and Testing Firm. A firm licensed to perform civil works construction inspection and testing services in accordance with the laws, regulations, and ordinances of the state of Nevada and Carson City.

Responsible Department. [~~Development services~~] **The Department** is responsible for overseeing compliance with this [~~manual~~] **Division** and for monitoring the construction and installation of public works infrastructure within the city.

The [~~engineering department~~] **Development Engineering Division of the Department** is responsible for the following categories: grading, storm drains, utility trenching by utility companies, curbs, gutters, sidewalks, roadways, roadway surface treatments, miscellaneous improvements, and survey monumentation.

The [engineering department acts for the utilities department] **Carson City Department of Public Works is responsible** for the following categories: sewer system improvements, water system improvements, reclaimed water system improvements, and other related activities.

Standard Details for Public Works Construction. As adopted by Carson City, herein after referred to as the SDPWC.

Standard Specifications for Public Works Construction. As adopted by Carson City, including amendments thereto, hereinafter referred to as the SSPWC.

Development Standards. As adopted by Carson City, including amendments thereto, hereinafter referred to as DS.

SECTION XXXX:

That Title 18 Appendix (CARSON CITY DEVELOPMENT STANDARDS), Division 21 (CONSTRUCTION OF IMPROVEMENTS INSPECTION & TESTING REQUIREMENT REPORTS), Section 21.3 (Inspection and testing firms) is hereby amended (**bold, underlined** text is added, [~~stricken~~] text is deleted) as follows:

21.3 Inspection and testing firms.

- a. General. The inspection and/or testing firm must have a current business license to perform work in Carson City. The firm must maintain general liability and property damage insurance and errors and omission insurance pursuant to the Carson City risk management policy. The services of the firm shall be performed under the direction of a civil ~~for~~ ~~geological~~ engineer licensed in the state of Nevada, pursuant to NRS 625, who is a member of the firm and has at least five (5) years engineering experience in the inspection and testing of construction methods and materials. The licensed engineer must be on the local staff and generally available for immediate site visits or other analysis. The inspection firm is responsible for inspections pursuant to these procedures, the DS, the SSPWC and the SDPWC. The testing firm is responsible for testing per these procedures, the DS, the SSPWC and the SDPWC. The firm is responsible for selecting the location and frequency of individual inspections or tests to [~~insure~~] **ensure** compliance.
- b. Disqualification. The firm is subject to disqualification for late, faulty, or incorrect inspections, tests or reports. For minor violations which have not resulted in acceptance of faulty work, the city will provide written notice of the deficiency. The firm will have up to five (5) working days to correct the deficiency in their operating procedures by describing such corrective action in a written response back to the city and a method for preventing future violations and/or deficiencies. A second violation within six (6) months may be cause for complete disqualification.

A firm may be immediately disqualified for fraud or deceit. All prior inspections or tests of the firm may then be subject to re-inspection or retesting to verify compliance with minimum standards, the cost of which shall be borne by the firm.

No provision herein is meant to limit additional legal or economic action against the firm for fraudulent activities.

- c. Laboratory Capability. The testing firm shall have the capability of performing all field and laboratory testing associated with its intended functions according to governing procedures and shall have the facilities and equipment required for all testing performed. If at any time equipment or expertise in the performance of a specialized test is not available in-house, the services of a subconsultant or their equipment may be utilized.

As evidence of its competence to perform the required tests or inspections, the firm shall submit documentation of current certification by a recognized public agency such as AASHTO.

- d. Quality of Testing Systems. The firm shall make available information (as applicable) describing its procedural systems (procedures which directly affect the quality of services offered). In addition, the firm shall maintain documentation which provides evidence of compliance with the requirements of its procedural systems. The firm's procedural systems shall include the following:
 - 1. Equipment calibration programs.
 - 2. Standardization of methods of test, measurement, and determination.
 - 3. Data recording, processing, and reporting.
 - 4. A current quality assurance manual.
 - 5. Current accepted test method procedures for all testing conducted.
 - 6. A safety manual prepared specifically for the testing and administration operations of this office.
- e. Technicians. Technicians shall be qualified to perform the functions described in this manual. Proof of qualification may be accepted by certification from an approved agency (i.e., ACI for concrete, etc.). Technicians shall be equipped with appropriate tools and instruments to perform their functions in an efficient and cost-effective manner.

SECTION XXXX:

That Title 18 Appendix (CARSON CITY DEVELOPMENT STANDARDS), Division 21 (CONSTRUCTION OF IMPROVEMENTS INSPECTION & TESTING REQUIREMENT REPORTS), Section 21.4 (Required inspection and testing) is hereby amended (**bold, underlined** text is added, [~~stricken~~] text is deleted) as follows:

21.4 Required inspection and testing.

- a. General Notes and Requirements for Inspectors. Inspectors are required to be on the project site to verify that:

1. Approved plans and valid permits including any approved revisions are on site. The city will provide one (1) copy of the approved plans to the permittee. It is the responsibility of the permittee to deliver the approved plans and copies of the permit to the inspection firm and all contractors or subcontractors working on the project. The permits that must be on the job site include NDOT occupancy permit (when in NDOT right-of-way), NDEP air quality operating permit, storm water discharge permit, dewatering permit, temporary rolling stock permit, or any special permits when required by statute or ordinance.
2. If required by the city, an approved traffic control plan is on site and that traffic control is being implemented in accordance with the plan.
3. Construction materials meeting the requirements of the DS, the SSPWC, the SDPWC and the approved project plans and specifications are being used.
4. The construction meets the requirements of the DS, the SSPWC, the SDPWC and the approved project plans and specifications.
5. Testing is being performed in conformance with these procedures, the DS, the SSPWC, the SDPWC, the approved project plans and specifications, and the criteria of the various testing agencies.

The inspector shall immediately direct the contractor to cease all work and shall notify the responsible department when any of the above requirements are not met by the contractor.

Inspections performed by the inspector generally will only cover work up to the time of inspection for the incremental unit of work being performed by the contractor. There is no presumption that work performed by the contractor on subsequent days or on other incremental units of a particular operation will be approved without further inspections.

The inspector is required to maintain a daily log, which at a minimum will detail each and every inspection made, the results, discussions, and directions to contractors, testers, city or other personnel, weather conditions, and any other pertinent data to support the results of all construction activities. Daily logs for work inspected Monday through Friday are due to the engineering department no later than 4:30 p.m. the following Monday (Tuesday if Monday is a holiday). For each inspection activity outlined in this manual, it is understood that the inspector must notify the contractor's assigned representative in writing that each inspection has passed or failed, and that a failure must be corrected before proceeding to the next phase of the activity.

In the event a contractor refuses to correct an item, the inspector shall note such action and immediately notify the city of the circumstances. The inspector shall inform the contractor that the city is being notified. ~~[Upon receiving such notice, the city will take appropriate action to resolve the issue.]~~ **Further inspections may not proceed unless specifically approved by the Director of the Department and the Director of the Carson City Department of Public Works.**

The inspector is expected to be fully familiar with all of the procedures, details and requirements of the SSPWC, as well as the specific drawings, notes, and specifications of the individual project.

The inspector is expected at all times to observe and review all traffic control measures used by the contractor. Should the inspector observe an unsafe condition, the inspector is expected to

notify the contractor's assigned representative. In the event a contractor ignores or refuses to correct the situation, the inspector shall note such action and immediately notify the appropriate federal, state or city department.

The inspector must note any changes or revisions to any alignment, grade, or design detail approved by the city and constructed by the contractor for the purposes of final as-built accuracy. The inspector shall provide the changes or revisions to the design professional responsible for preparation of the record drawings.

Should the city deem it necessary to order work on the project to cease, the inspection firm and testing firm shall be notified and shall not perform any additional inspections or testing until directed to do so by the city. Performance of inspections or testing without direction from the city will result in the immediate removal of the respective firm from the project.

The inspection and testing firms will be required to provide the city with a certification that the project inspection or testing complied with the standards referenced herein.

b. Inspection and Testing Categories.

1. Grading: Category to include all grading activities, removals and demolitions.

(a) Clearing and Grubbing: No inspections generally required.

(b) Removal of Buildings/Structures: Work is generally covered under a separate permit from the building department with inspections by building inspector and manifesting of hazardous materials by the health department. Abandonment of water and sewer facilities require inspections by the engineering department if specified on the permit.

(c) Removal of Curb and Gutter, Sidewalk, Driveways, Asphalt, Pipes, Structures, etc.:

(1) General Site Inspection—A minimum of one (1) inspection per incremental area of material being removed by contractor.

(i) Inspect to verify that removals are done in accordance with plans and specifications.

(ii) Inspect to verify that removal of concrete materials meets specifications with regard to joint locations.

(iii) Inspect to ~~insure~~ **ensure** that temporary service measures are in place prior to pipe removal.

(iv) Inspect to ~~insure~~ **ensure** that pipe and other appurtenances are protected from damage and debris infiltration.

(2) Follow up Inspection—A minimum of one (1) inspection per incremental area of material removed by contractor.

(i) Inspect to ~~insure~~ **ensure** that proper saw cuts have been made and material removed prior to asphalt pavement repairs.

(ii) Inspect to ~~insure~~ **ensure** that all deleterious materials have been removed prior to pipe system hookups.

- (d) Grading:
- (1) General Site Grading—A minimum of one (1) inspection per site specific location.
 - (i) Inspect to [~~insure~~] **ensure** that no drainage is being diverted to adjacent properties or that existing drainage channels are not being modified except as authorized by the approved plans.
 - (ii) Inspect to confirm that excess material is being taken to a proper approved location.
 - (2) Cut Slopes/Fill Slopes—A minimum of one (1) inspection per incremental unit of work by contractor.
 - (i) Inspect to verify that the cut and/or fill slopes have been placed in accordance with the plans when notified by the contractor that slopes have been completed.
 - (3) Drainage Swales/Channels—A minimum of one (1) inspection per incremental unit of work by contractor.
 - (i) Inspect for possible obstructions (i.e. power poles, hydrants, manholes, etc.).

Inspect for obvious vertical or horizontal alignment problems.

Inspect to verify the grade and alignment meet the requirements of the plans and specifications.
 - (4) Detention Basins—A minimum of one (1) inspection per basin location.
 - (i) Inspect to verify that the basin conforms to the plans and specifications for location and slopes.
 - (5) Fill Compaction—A minimum of one (1) inspection daily during any fill compaction activities by contractor.
 - (i) [~~insure~~] **Ensure** that backfill material meets required specifications.
 - (ii) Inspect to verify that fill is being placed in proper lifts in accordance with the project plans and specifications.
 - (iii) Inspect to [~~insure~~] **ensure** that proper compaction has been accomplished meeting the project specifications by verifying compaction test results from testing firm and by visual observation of 'pumping' or other deficiencies.
2. Sewer Mains and Appurtenances. Category to include sewer mains, laterals, manholes and appurtenances.
- (a) Site Overview Inspection—Minimum of one (1) inspection per increment unit of work by contractor.
 - (1) Inspect for possible obstructions (i.e., power poles, hydrants, etc.).

- (2) Inspect for obvious vertical or horizontal alignment or location conflicts (i.e., buried utilities).

NOTE: USA dig locations must be complete prior to performing this inspection.

- (3) Inspect manhole plug installation and verify plug is braced and tied off properly to prevent blockage of downstream lines due to plug failures. Schedule manhole plug inspection, engineering department inspector must approve the installation in writing prior to proceeding with any subsequent inspections.
- (b) Trench or Manhole Excavation Inspection—Minimum of one (1) inspection per increment unit of work by contractor.
- (1) Inspect excavation slopes and depths for minimum safety standards per project specifications or state and federal requirements.
 - (2) Inspect bottom of excavation prior to placing of bedding, pipe or manhole to ~~[insure]~~ **ensure** that subgrade material is in general conformance with design grade and alignment or location.
 - (3) Inspect to ~~[insure]~~ **ensure** that subgrade material is uniform and free of excess moisture and deleterious material.
 - (4) Inspect to ~~[insure]~~ **ensure** that trench excavation widths and grades are in conformance with project plans and specifications.
 - (5) Inspect to ~~[insure]~~ **ensure** that manhole location and invert elevations have been laid out by a licensed engineer or land surveyor for slopes less than 0.4%.
 - (6) Inspect to ~~[insure]~~ **ensure** proper compaction methods are utilized.
- (c) Bedding Inspections—Minimum of one (1) inspection per increment unit of work by contractor.
- (1) Inspect to determine that native material is suitable for bedding or whether imported bedding material is required as per the specifications by verifying test results from the testing firm.
 - (2) If imported bedding is utilized, inspect to ~~[insure]~~ **ensure** that the material meets the project specifications by verifying test results from the testing firm.
 - (3) Inspect to ~~[insure]~~ **ensure** that bedding material is placed at the proper depth and is properly compacted in conformance with the project specifications by verifying compaction test results from testing firm.
- (d) Pipe Inspections—Minimum of one (1) inspection per increment unit of work by contractor.
- (1) Inspect to ~~[insure]~~ **ensure** that pipe supplied to the project meets the plans and specifications including material and class and is not broken or defective.

- (2) Inspect to [~~insure~~] **ensure** that pipe is laid properly in conformance to the design alignment and grade and to the specifications.
 - (3) Inspect to insure minimum horizontal and vertical clearances are met or other approved method is installed if required by the plans and specifications.
 - (4) Inspect to [~~insure~~] **ensure** that the pipe is laid with bell ends uphill and is properly jointed in accordance with the specifications.
 - (5) Verify main lines which do not end in a manhole are surveyed by a licensed engineer or land surveyor for line and grade prior to backfill.
 - (6) Inspect to [~~insure~~] **ensure** that sewer lateral wyes and tees are placed at a minimum of forty-five (45) degrees above the spring line and that lateral ends are marked. Note-sewer laterals are not allowed to be tied into any manhole.
 - (7) Inspect to [~~insure~~] **ensure** that pipe core drill and saddle taps conform to the plans.
- (e) Bedding Backfill Inspections—Minimum of one (1) inspection per increment unit of work by contractor in each zone: bedding to spring line, spring line to top of pipe, and top of pipe to one foot (1') above top of pipe.
- (1) Inspect to confirm adequacy of bedding material in conformance with specifications.
 - (2) Inspect that bedding backfill operation is in conformance with specifications for proper lifts and compaction by verifying any compaction test results from testing firm.
 - (3) Inspect to [~~insure~~] **ensure** hand tamping bars are utilized to compact bedding material under pipe haunches.
 - (4) Verify warning tape is laid in trench one foot (1') above pipe.
- (f) Precast Manhole Inspections—Minimum of one (1) inspection per manhole.
- (1) Inspect to [~~insure~~] **ensure** that precast manhole meets the project specifications.
 - (2) Inspect to insure that precast structure is the proper diameter and is placed at proper grade and alignment and that proper connections are made with pipes in conformance with the plans and specifications.
 - (3) Inspect to [~~insure~~] **ensure** double layer of mastic material is placed between joints and that ladder and pick holes are properly grouted.
- (g) Poured-in-Place Manhole Inspections—Minimum of one (1) inspection per manhole for bedding, forms, and connections.
- (1) Inspect to [~~insure~~] **ensure** that the base material is properly prepared for forms for poured-in-place manhole.

- (2) Inspect to [~~insure~~] **ensure** that form layout is in conformance with the plans and specifications for alignment and grade, forms material and workmanship, and steel size, number, location and installation.
- (h) Poured-in-Place Concrete Placement Inspections—Minimum of one (1) inspection per manhole.
 - (1) [~~insure~~] **Ensure** that weather conditions are appropriate per specification requirements.
 - (2) Inspect to reconfirm that base material, forms and steel have not changed.
 - (3) Inspect first truck delivery of the day to [~~insure~~] **ensure** that the material meets the specifications and is from an approved source.
 - (4) Inspect the material out of the truck, using judgement to determine if the material is appropriate to pour and call in testing firm immediately if there is any question.
 - (5) Inspect general placement, workmanship and finishing activities of the contractor's crew.
 - (6) Inspect to [~~insure~~] **ensure** that cold weather blankets, or other materials are on hand when required by specifications.
 - (7) Within first or second day of pour, inspect to [~~insure~~] **ensure** that proper connections have been made, manhole channel and shelves are finished in accordance with the SDPWC and proper finish has been performed and work is free from cracks or other deficiencies.
 - (8) Inspect to [~~insure~~] **ensure** that concrete meets specifications by receiving testing results from testing firm and verifying compliance.
- (i) Trench or Structure Backfill Inspections—Minimum of one (1) inspection per structure and one (1) inspection per increment unit of trench work by contractor.
 - (1) Inspect trench/structure backfill material for adequacy in conformance with specifications.
 - (2) Inspect to insure that backfill is placed in proper lifts and meets specifications for compaction by verifying compaction test results from testing firm as required.
 - (3) Inspect to insure that backfill is brought completely to finish surface grade or to pavement section subgrade elevation as appropriate in accordance with the project plans and specifications.
- (j) Sewer Final Inspection and Testing
 - (1) Vacuum test all manholes in accordance with the specifications.
 - (2) Pressure test all mains and laterals in accordance with the specifications.
 - (3) Inspect ball, flush and mandreling of all sewer mains in accordance with the specifications. Note: line must be clean.

- (4) Contact the sewer utility to schedule the televising inspection, inspection will be scheduled within five (5) working days.

Note: Ball, flush and mandrel inspection must be complete and line must have water in it to be televised.

- (5) Inspect to [~~insure~~] **ensure** manhole frame and covers are in accordance with the specifications and are set to grade with no more than twelve inches (12") of grade rings.
- (6) Inspect to [~~insure~~] **ensure** concrete collars are installed with rebar when located outside paved areas.
- (7) Inspect to [~~insure~~] **ensure** manholes and lines are free of dirt, debris, and grout following adjustment of manholes to grade.
- (8) Inspect installation of manhole markers for location and conformance with the plans.
- (9) Inspect to [~~insure~~] **ensure** all lateral markers are in place.
- (10) Inspect to [~~insure~~] **ensure** plug is removed after all other inspections have been completed and accepted by [~~Carson City engineering-~~] **the Development Engineering Division of the Department.**

3. Storm Drains and Appurtenances. Category to include storm mains, inlet laterals, culverts, detention facilities, manholes, inlets, detention structures, etc.

- (a) Site Overview Inspection—Minimum of one (1) inspection per increment unit of work by contractor.
 - (1) Inspect for possible obstructions (i.e., power poles, hydrants, etc.).
 - (2) Inspect for obvious vertical or horizontal alignment or location conflicts (i.e., buried utilities).

NOTE: USA dig locations must be complete prior to performing this inspection.

- (b) Trench or Structure Excavation Inspection—Minimum of one (1) inspection per increment unit of work by contractor.
 - (1) Inspect excavation slopes and depths for minimum safety standards per project specifications or state and federal requirements.
 - (2) Inspect bottom of excavation prior to placing of bedding, pipe or structure to [~~insure~~] **ensure** that subgrade material is in general conformance with design grade and alignment or location.
 - (3) Inspect to [~~insure~~] **ensure** that subgrade material is uniform and free of excess moisture and deleterious material.
 - (4) Inspect to [~~insure~~] **ensure** that trench excavation widths and grades are in conformance with project plans and specifications.
- (c) Bedding Inspections—Minimum of one (1) inspection per increment unit of work by contractor.

- (1) Inspect to determine that native material is suitable for bedding or whether imported bedding material is required as per the specifications by verifying test results from the testing firm.
 - (2) If imported bedding is utilized, inspect to [~~insure~~] **ensure** that the material meets the project specifications by verifying test results from the testing firm.
 - (3) Inspect to [~~insure~~] **ensure** that bedding material is placed at the proper depth and is properly compacted in conformance with the project specifications by verifying compaction test results from testing firm.
- (d) Pipe Inspections—Minimum of one (1) inspection per increment unit of work by contractor.
- (1) Inspect to [~~insure~~] **ensure** that pipe supplied to the project meets the plans and specifications including material and class and is not broken or defective.
 - (2) Inspect to [~~insure~~] **ensure** that pipe is laid properly in conformance to the design alignment and grade and to the specifications.
 - (3) Inspect to insure minimum horizontal and vertical clearances are met and encasement is installed if required by the plans and specifications.
 - (4) [~~insure~~] **Ensure** that the pipe is laid with bell ends uphill and is properly jointed in accordance with the specifications.
- (e) Bedding Backfill Inspections—Minimum of one (1) inspection per increment unit of work by contractor in each zone: bedding to spring line, spring line to top of pipe, and top of pipe to one foot (1') above top of pipe.
- (1) Inspect to confirm adequacy of bedding material in conformance with specifications.
 - (2) Inspect that bedding backfill operation is in conformance with specifications for proper lifts and compaction by verifying any compaction test results from testing firm.
 - (3) Verify warning tape is laid in trench one foot (1') above pipe.
- (f) Precast Structure Inspections—Minimum of one (1) inspection per structure.
- (1) Inspect to [~~insure~~] **ensure** that precast catch basin, manhole or other structure meets the project specifications.
 - (2) Inspect to [~~insure~~] **ensure** that precast structure is proper size and is placed at proper grade and alignment and that proper connections are made with pipes or other connections in conformance with the plans and specifications.
- (g) Poured-in-Place Structure Inspections—Minimum of one (1) inspection per structure for bedding, forms, and connections.
- (1) Inspect to [~~insure~~] **ensure** that the base material is properly prepared for forms for poured-in-place catch basin, manhole, headwall, detention basin

weir, spillway, outlet structure, concrete lined ditch or swale, or any other storm structure.

- (2) Inspect to ~~insure~~ **ensure** that form layout is in conformance with the plans and specifications for alignment and grade, forms material and workmanship, and steel size, number, location and installation.
- (h) Poured-in-Place Concrete Placement Inspections—Minimum of one (1) inspection per structure plus one additional inspection during placing operation for each one hundred fifty (150) cubic yards of concrete poured per day.
- (1) ~~insure~~ **ensure** that weather conditions are appropriate per specification requirements.
 - (2) Inspect to reconfirm that base material, forms and steel have not changed.
 - (3) Inspect first truck delivery of the day to ~~insure~~ **ensure** that the material meets the specifications and is from an approved source.
 - (4) Inspect the material out of the truck, using judgement to determine if the material is appropriate to pour and call in testing firm immediately if there is any question.
 - (5) Inspect general placement, workmanship and finishing activities of the contractor's crew.
 - (6) Inspect to ~~insure~~ **ensure** that cold weather blankets, or other materials are on hand when required by specifications.
 - (7) Within first or second day of pour, inspect to ~~insure~~ **ensure** that proper connections have been made, that manhole channels and shelves are finished in accordance with the SDPWC and proper finish has been performed and work is free from cracks or other deficiencies.
 - (8) Inspect to ~~insure~~ **ensure** that concrete meets specifications by receiving testing results from testing firm and verifying compliance.
- (i) Trench or Structure Backfill Inspections—Minimum of one (1) inspection per structure and one (1) inspection per increment unit of trench work by contractor.
- (1) Inspect trench/structure backfill material for adequacy in conformance with specifications.
 - (2) Inspect to insure that backfill is placed in proper lifts and meets specifications for compaction by verifying compaction test results from testing firm as required.
 - (3) Inspect to insure that backfill is brought completely to finish surface grade or to pavement section subgrade elevation as appropriate in accordance with the project plans and specifications.
- (j) Rip-rap Material Inspections—Minimum of one (1) inspection per structure or increment unit of work by contractor.

- (1) Inspect to [~~insure~~] **ensure** that ditch or swale to have rip-rap treatment meets design grades and alignment or that headwall, spillway or other structure to be rip-rap treated meets location and elevation design.
- (2) Inspect to [~~insure~~] **ensure** that rip-rap material supplied meets project specifications.
- (k) Detention/Retention Basin Inspections—Minimum of one (1) inspection per detention basin facility.
 - (1) Inspect to [~~insure~~] **ensure** that all inlet and outlet structures are completed and operational in conformance with project plans and specifications.
 - (2) Inspect to [~~insure~~] **ensure** that basin slope treatments and/or landscaping are in conformance with project plans and specifications.
- (l) Storm Drain Final Inspection and Testing.
 - (1) Pressure test all mains and laterals in accordance with the specifications.
 - (2) Inspect to [~~insure~~] **ensure** manhole frame and covers are in accordance with the specifications and are set to grade with no more than eighteen inches (18") of grade rings.
 - (3) Inspect to [~~insure~~] **ensure** concrete collars are installed with rebar when located outside paved areas.
 - (4) Inspect to [~~insure~~] **ensure** manholes and lines are free of dirt and debris following adjustment of manholes to grade.
- 4. Water Mains and Appurtenances. Category to include water mains, service laterals, hydrants, fire lines, fire sprinkler lines from main to check assembly, backflow prevention devices and appurtenances.
 - (a) Site Overview Inspection—Minimum of one (1) inspection per increment unit of work by contractor.
 - (1) Inspect for possible obstructions (i.e., power poles, hydrants, etc.).
 - (2) Inspect for obvious vertical or horizontal alignment or location conflicts (i.e., buried utilities).

NOTE: USA Dig locations must be complete prior to performing this inspection.
 - (b) Trench or Structure Excavation Inspection—Minimum of one (1) inspection per increment unit of work by contractor.
 - (1) Inspect excavation slopes and depths for minimum safety standards per project specifications or state and federal requirements.
 - (2) Inspect bottom of excavation prior to placing of bedding, pipe or structure to [~~insure~~] **ensure** that subgrade material is in general conformance with design grade and alignment or location.
 - (3) Inspect to [~~insure~~] **ensure** that subgrade material is uniform and free of excess moisture and deleterious material.

- (4) Inspect to [~~insure~~] **ensure** that trench excavation widths and grades are in conformance with project plans and specifications.
- (c) Bedding Inspections—Minimum of one (1) inspection per increment unit of work by contractor.
- (1) Inspect to determine that native material is suitable for bedding or whether imported bedding material is required as per the specifications by verifying test results from the testing firm.
 - (2) If imported bedding is utilized, inspect to [~~insure~~] **ensure** that the material meets the project specifications by verifying test results from the testing firm.
 - (3) Inspect to [~~insure~~] **ensure** that bedding material is placed at the proper depth and is properly compacted in conformance with the project specifications by verifying compaction test results from testing firm.
- (d) Pipe Inspections—Minimum of one (1) inspection per increment unit of work by contractor.
- (1) Inspect to [~~insure~~] **ensure** that pipe supplied to the project meets the plans and specifications including material and class and is not broken or defective.
 - (2) Inspect to [~~insure~~] **ensure** that pipe is laid properly in conformance to the design alignment and grade and to the specifications.
 - (3) Inspect to insure minimum horizontal and vertical clearances are met and encasement is installed if required by the plans and specifications.
 - (4) Inspect to [~~insure~~] **ensure** that the pipe is properly jointed in accordance with the specifications.
 - (5) Inspect to insure tap saddle is proper type and installed as per the manufacturers recommendations. Note: tapping sleeve pressure test must be witnessed by the utilities department prior to performing tap.
 - (6) Inspect to [~~insure~~] **ensure** that water laterals are installed in accordance with the approved plans, including proper service saddles and fittings, angle of service at main, separation from other fittings, corporation stop is open, and location.
 - (7) Inspect to [~~insure~~] **ensure** corporation stop is off and service saddle is in good condition, or replaced with a repair clamp, and a twelve-inch (12") (minimum) section of service line is removed and plugged when abandoning a service lateral. Meter box must be removed and meter returned to the water utility division.
 - (8) Inspect to insure that thrust blocks are installed in accordance with the approved plans and that pipe, bolts, nuts and hydrant weep holes are free and clear of concrete and bolts and nuts are accessible with a wrench for maintenance. Verify that thrust blocks are installed at all bends, tees, crosses,

tapping sleeves, hydrants, valves, flush valve assemblies etc., and are no larger or smaller than required.

- (9) Inspect to [~~insure~~] **ensure** all valves are the proper type and are installed plumb.
- (10) Inspect to [~~insure~~] **ensure** all hydrants are the proper type, installed plumb, painted the proper color, installed with a 10-7 ring, drain holes are clear, and hydrant form filled out.

Note: Hydrant form cannot be completed until valves are permanently adjusted to grade.

- (11) Inspect to [~~insure~~] **ensure** backflow prevention devices are installed in accordance with the plans, that check assemblies are the proper type, and check valves are installed in the proper direction, support is in place, and valve at main is open.
 - (12) Inspect to [~~insure~~] **ensure** locator wire is the proper type and is taped on top of all pipe lines every six feet (6') including service laterals and fire lines to the check assembly.
 - (13) Inspect to [~~insure~~] **ensure** flush valve assemblies are installed with proper separation from valve and four inch (4") riser, pressure plate installed properly, riser is set at proper depth below finish grade and has a drain hole, manganese is installed properly, and locator wire is accessible.
 - (14) Inspect to [~~insure~~] **ensure** air release assemblies are installed with proper valve, proper separation from goose neck vent and finish grade and is screened, positive slope on pipe, main connection is open, and locator wire is accessible.
- (e) Bedding Backfill Inspections—Minimum of one (1) inspection per increment unit of work by contractor in each zone: bedding to spring line, spring line to top of pipe, and top of pipe to one foot (1') above top of pipe.
- (1) Inspect to confirm adequacy of bedding material in conformance with specifications.
 - (2) Inspect that bedding backfill operation is in conformance with specifications for proper lifts and compaction by verifying any compaction test results from testing firm.
 - (3) Inspect to [~~insure~~] **ensure** hand tamping bars are utilized to compact bedding material under pipe haunches.
 - (4) Verify warning tape is laid in trench one inch (1") above pipe.
- (f) Structure Inspections—Minimum of one (1) inspection per manhole.
- (1) Inspect to [~~insure~~] **ensure** that structures meet the project specifications.
 - (2) Inspect to [~~insure~~] **ensure** that structure is the proper size and is placed at proper grade and alignment and that proper connections are made with pipes in conformance with the plans and specifications.

- (3) Inspect to [~~insure~~] **ensure** double layer of mastic material is placed between joints and that ladder and pick holes are properly grouted when structures are subject to ground water infiltration.
 - (4) Inspect to insure proper clearances between devices and structure walls and floor.
 - (5) Inspect to [~~insure~~] **ensure** locator wire is accessible.
- (g) Trench or Structure Backfill Inspections—Minimum of one (1) inspection per structure and one (1) inspection per increment unit of trench work by contractor.
- (1) Inspect trench/structure backfill material for adequacy in conformance with specifications.
 - (2) Inspect to insure that backfill is placed in proper lifts and meets specifications for compaction by verifying compaction test results from testing firm as required.
 - (3) Inspect to insure that backfill is brought completely to finish surface grade or to pavement section subgrade elevation as appropriate in accordance with the project plans and specifications.
- (h) Water Final Inspection and Testing
- (1) Pressure test all mains and laterals in accordance with the standard specifications, verify valves are open or closed as appropriate, provide test calculations and results to the utilities department inspector.
 - (2) Chlorine test all mains and laterals in accordance with the specifications, verify valves are open or closed as appropriate, provide test results to the utilities department inspector.
 - (3) Inspect to insure all mains and laterals are flushed clean and valves are open.
 - (4) Schedule the bacteria test. Inspection will be scheduled and performed by the utilities inspector within five (5) working days.
 - Note: The pressure and chlorine tests and flushing must be complete to schedule this test; samples cannot be taken on Friday or the day preceding a holiday. No bacteria samples can be done after 2:00 p.m. Thursday.
 - (5) Verify backflow prevention assemblies are tested by an approved tester and results forwarded to the water division of the utility department.
 - Note: Water meters will not be set until sewer and water lines have been inspected, tested and passed including bacteria and backflow tests.
 - (6) Inspect to [~~insure~~] **ensure** manhole frame and covers are in accordance with the specifications and are set to grade with no more than twelve inches (12") of grade rings.
 - (7) Inspect to [~~insure~~] **ensure** concrete collars are installed with rebar when located outside paved areas.

- (8) Inspect to [~~insure~~] **ensure** valves, structures, vaults, meter boxes and pit setters are free of dirt and debris following adjustment to grade.
 - (9) Inspect valve can and riser to [~~insure~~] **ensure** valve operating nut is accessible and operational, and locator wire is accessible.
 - (10) Inspect to [~~insure~~] **ensure** lids are marked "water."
 - (11) Inspect installation of valve markers for location and conformance with the plans.
5. Reclaimed Water Mains and Appurtenances. Category to include reclaimed water mains, service laterals, hydrants and appurtenances.
- (a) Site Overview Inspection—Minimum of one (1) inspection per increment unit of work by contractor.
- (1) Inspect for possible obstructions (i.e., power poles, hydrants, etc.).
 - (2) Inspect for obvious vertical or horizontal alignment or location conflicts (i.e., buried utilities).

NOTE: USA dig locations must be complete prior to performing this inspection.

- (b) Trench or Structure Excavation Inspection—Minimum of one (1) inspection per increment unit of work by contractor.
- (1) Inspect excavation slopes and depths for minimum safety standards per project specifications or state and federal requirements.
 - (2) Inspect bottom of excavation prior to placing of bedding, pipe or structure to [~~insure~~] **ensure** that subgrade material is in general conformance with design grade and alignment or location.
 - (3) Inspect to [~~insure~~] **ensure** that subgrade material is uniform and free of excess moisture and deleterious material.
 - (4) Inspect to [~~insure~~] **ensure** that trench excavation widths and grades are in conformance with project plans and specifications.
- (c) Bedding Inspections—Minimum of one (1) inspection per increment unit of work by contractor.
- (1) Inspect to determine that native material is suitable for bedding or whether imported bedding material is required as per the specifications by verifying test results from the testing firm.
 - (2) If imported bedding is utilized, inspect to [~~insure~~] **ensure** that the material meets the project specifications by verifying test results from the testing firm.
 - (3) Inspect to [~~insure~~] **ensure** that bedding material is placed at the proper depth and is properly compacted in conformance with the project specifications by verifying compaction test results from testing firm.

- (d) Pipe Inspections—Minimum of one (1) inspection per increment unit of work by contractor.
- (1) Inspect to ~~insure~~ **ensure** that pipe supplied to the project meets the plans and specifications including material, class and color (purple) and is not broken or defective.
 - (2) Inspect to ~~insure~~ **ensure** that pipe is laid properly in conformance to the design alignment and grade and to the specifications.
 - (3) Inspect to insure minimum horizontal and vertical clearances are met and encasement is installed if required by the plans and specifications.
 - (4) Inspect to ~~insure~~ **ensure** that the pipe is properly jointed in accordance with the specifications.
 - (5) Inspect to insure tap saddle is proper type and installed as per the manufacturers recommendations. Observe tapping sleeve pressure test prior to performing tap. Contractor or testing firm to supply testing equipment.
 - (6) Inspect to insure that reclaimed water laterals are installed in accordance with the approved plans, including proper service saddles and fittings, angle of service at main, separation from other fittings, corporation stop is open, and location.
 - (7) Inspect to ~~insure~~ **ensure** corporation stop is off and service saddle is in good condition, or replaced with a repair clamp, and a twelve-inch (12") (minimum) section of service line is removed and plugged when abandoning a service lateral. Meter box must be removed and meter returned to the wastewater division of the ~~[utility department.]~~ **Carson City Public Works Department.**
 - (8) Inspect to insure that thrust blocks are installed in accordance with the approved plans and that pipe, bolts, nuts and hydrant weep holes are free and clear of concrete and bolts and nuts are accessible with a wrench for maintenance. Verify that thrust blocks are installed at all bends, tees, crosses, tapping sleeves, hydrants, valves etc., and are no larger or smaller than required.
 - (9) Inspect to ~~insure~~ **ensure** all valves are the proper type and are installed plumb.
 - (10) Inspect to ~~insure~~ **ensure** all hydrants are the proper type, painted purple, and drain holes are clear.
 - (11) Inspect to ~~insure~~ **ensure** pressure regulating devices are installed in accordance with the plans, that check assemblies are the proper type, and check valves are installed in the proper direction, support is in place, and valve at main is open. See standard details.
 - (12) Inspect to ~~insure~~ **ensure** locator wire is the proper type and is taped on top of all pipe lines including service laterals every six feet (6').

- (13) Inspect to ~~insure~~ **ensure** air/vacuum release assemblies are installed with proper valve, proper separation from goose neck vent and finish grade and is screened, positive slope on pipe, main connection is open, and locator wire is accessible.
- (e) Bedding Backfill Inspections—Minimum of one (1) inspection per increment unit of work by contractor in each zone: bedding to spring line, spring line to top of pipe, and top of pipe to one foot (1') above top of pipe.
 - (1) Inspect to confirm adequacy of bedding material in conformance with specifications.
 - (2) Inspect that bedding backfill operation is in conformance with specifications for proper lifts and compaction by verifying any compaction test results from testing firm. See standard details.
 - (3) Inspect to ~~insure~~ **ensure** hand tamping bars are utilized to compact bedding material under pipe haunches.
 - (4) Verify warning tape is laid in trench one foot (1') above pipe.
- (f) Structure Inspections—Minimum of one (1) inspection per manhole.
 - (1) Inspect to ~~insure~~ **ensure** that structures meet the project specifications.
 - (2) Inspect to ~~insure~~ **ensure** that structure is the proper size and is placed at proper grade and alignment and that proper connections are made with pipes in conformance with the plans and specifications.
 - (3) Inspect to ~~insure~~ **ensure** double layer of mastic material is placed between joints and that ladder and pick holes are properly grouted when structures are subject to ground water infiltration.
 - (4) Inspect to insure proper clearances between devices and structure walls and floor.
 - (5) Inspect to ~~insure~~ **ensure** locator wire is accessible.
- (g) Trench or Structure Backfill Inspections—Minimum of one (1) inspection per structure and one (1) inspection per increment unit of trench work by contractor.
 - (1) Inspect trench/structure backfill material for adequacy in conformance with specifications.
 - (2) Inspect to insure that backfill is placed in proper lifts and meets specifications for compaction by verifying compaction test results from testing firm as required.
 - (3) Inspect to insure that backfill is brought completely to finish surface grade or to pavement section subgrade elevation as appropriate in accordance with the project plans and specifications.
- (h) Reclaimed Water Final Inspection and Testing
 - (1) Pressure test all mains and laterals in accordance with the specifications, (two hundred (200) psi minimum) verify valves are open or closed as

appropriate, provide test calculations and results to the utilities department inspector.

- (2) Inspect to [~~insure~~] **ensure** all mains and laterals are flushed clean and valves are open.
- (3) Inspect to [~~insure~~] **ensure** manhole frame and covers are in accordance with the specifications and are set to grade with no more than twelve inches (12") of grade rings.
- (4) Inspect to [~~insure~~] **ensure** concrete collars are installed with rebar when located outside paved areas.
- (5) Inspect to [~~insure~~] **ensure** valves, structures, vaults, meter boxes and pit setters are free of dirt and debris following adjustment to grade.
- (6) Inspect valve can and riser (riser pipe must be purple in color) to [~~insure~~] **ensure** valve operating nut is accessible and operational, and locator wire is accessible on the outside of the riser.
- (7) Inspect to [~~insure~~] **ensure** lids are marked "reclaimed water" or "RCW."
- (8) Inspect installation of valve markers for location and conformance with the plans.

6. Utility Trenching and Appurtenances by the Utility Companies.

Category to include utility trenching, bedding, conduits, backfill, vaults, boxes and pads installed by or under the order of the utility companies and permitted by Carson City (i.e., SPPC, NV Bell, SW Gas, ATT etc.).

- (a) General Inspections—Minimum of one (1) inspection per increment unit of utility work by contractor plus one (1) daily inspection of temporary pavement patches.
 - (1) Inspect excavation slopes and depths for minimum safety standards per project specifications or state and federal requirements.
 - (2) Inspect for proper horizontal and vertical clearance from existing or proposed water and sewer facilities.
 - (3) Upon installation of utility facility, inspect backfill material for adequacy in conformance with specifications and insure that backfill is placed in proper lifts up to finished surface grade or pavement subgrade and meets specifications for compaction.
 - (4) For work in an existing paved area, inspect to [~~insure~~] **ensure** that any temporary patches are adequate and maintained in an acceptable condition in accordance with the specifications.
 - (5) Inspect to [~~insure~~] **ensure** the permanent pavement patch is in accordance with the plans and specifications and inspections according to the pavement and appurtenances section.
7. Curb & Gutter, and Sidewalk and Appurtenances. Category to include curb and gutter, valley gutter, sidewalk, and driveways.

- (a) Site Overview Inspection—Minimum of one (1) inspection per increment unit of work by contractor.
 - (1) Inspect for possible obstructions (i.e., power poles, hydrants, etc.).
 - (2) Inspect for obvious vertical or horizontal alignment problems.
- (b) Subgrade Inspection—Minimum of one (1) inspection per increment unit of work by contractor.
 - (1) Inspect to ~~insure~~ **ensure** that subgrade material or compacted fill material is in general conformance with design grade and alignment.
 - (2) Inspect to ~~insure~~ **ensure** that subgrade material or compacted fill material is reasonably uniform and free of deleterious material and excess moisture.
 - (3) At the conclusion of compaction activity, ~~insure~~ **ensure** that proper compaction meeting the project specifications has been done by verifying compaction test results from testing firm and by visual observation of 'pumping' or other deficiencies.
- (c) Base Inspection—Minimum of one (1) inspection per increment unit of work by contractor.
 - (1) Inspect to ~~insure~~ **ensure** that the base material meets the specifications and that the material is from an approved source or pit.
 - (2) Inspect to ~~insure~~ **ensure** that the base material is in general conformance with design grade and alignment and proper depth.
 - (3) Inspect to ~~insure~~ **ensure** that the base material is uniform and free of deleterious material and excess moisture.
 - (4) Inspect to ~~insure~~ **ensure** that compaction of base material is done in proper lifts as per the specifications and at the conclusion of compaction activity, insure that proper compaction has been done by verifying compaction test results from testing firm and by visual observation of 'pumping' or other deficiencies.
- (d) Forms Inspection—Minimum of one (1) inspection per increment unit of work by contractor plus one (1) additional inspection for each five hundred (500) linear feet of sidewalk or curb and gutter included in the increment unit of work.
 - (1) Inspect to reconfirm the appropriate condition of the base material.
 - (2) Inspect to ~~insure~~ **ensure** that the forms layout is in conformance with the plans for alignment, grade and thickness.
 - (3) Inspect to ~~insure~~ **ensure** that the forms material and workmanship are in conformance with the specifications.
 - (4) If a continuous pour lay down machine is used to install curb and gutter, inspect all string lines and guides to insure proper alignment and grade.
 - (5) If wire mesh or steel is required, inspect to ~~insure~~ **ensure** that mesh or steel meets the specifications for size, number, location and proper installation.

- (e) Concrete Placement Inspection—Minimum of one (1) inspection per increment unit of work by contractor plus one (1) additional inspection during placing operation for each one hundred fifty (150) cubic yards of concrete poured per day.
- (1) [~~insure~~] **Ensure** that weather conditions are appropriate per specification requirements.
 - (2) Inspect to reconfirm that base material, forms and steel have not changed.
 - (3) Inspect first truck delivery of the day to [~~insure~~] **ensure** that the material meets the specifications and is from an approved source.
 - (4) Inspect the material out of the truck, using your judgement to determine if the material is appropriate to pour and call in testing firm immediately if there is any question.
 - (5) Inspect general placement, workmanship and finishing activities of the contractor's crew.
 - (6) Inspect to [~~insure~~] **ensure** that expansion joint materials, cold weather blankets, or other materials are on hand when required by specifications.
 - (7) Inspect to insure that "S" is stamped in curb at all lateral locations.
 - (8) Within first or second day of pour, inspect to [~~insure~~] **ensure** that proper joints and joint materials have been placed, proper finish has been performed and work is free from cracks or other deficiencies.
 - (9) Inspect to [~~insure~~] **ensure** that concrete meets specifications by receiving testing results from testing firm and verifying compliance.
- (f) Final Inspection—Minimum of one (1) inspection per unit increment of work by contractor.

Upon completion of all backfill activities and/or paving activities and clean up around curb and gutter, valley gutter, sidewalk, or driveway, inspect to insure that installations clean and damage free.

8. Pavement and Appurtenances

- (a) Site Overview Inspection—Minimum of one (1) inspection per increment unit of work by contractor.
- (1) Inspect for possible obstructions (i.e., power poles, hydrants, etc.).
 - (2) Inspect for obvious vertical or horizontal alignment problems.
- (b) Subgrade Inspection—Minimum of one (1) inspection per increment unit of work by contractor to include walking entire section.
- (1) Inspect to [~~insure~~] **ensure** that subgrade material or compacted fill material is in general conformance with design grade and alignment.
 - (2) Inspect to [~~insure~~] **ensure** that subgrade material or compacted fill material is reasonably uniform and free of deleterious material and excess moisture.

- (3) At the conclusion of compaction activity, [~~insure~~] **ensure** that proper compaction meeting the project specifications has been done by verifying compaction test results from testing firm and by visual observation of 'pumping' or other deficiencies.
- (c) Base Inspection—Minimum of one (1) inspection per increment unit of work by contractor to include walking entire section.
- (1) Inspect to [~~insure~~] **ensure** that the base material meets the specifications and that the material is from an approved source or pit.
 - (2) Inspect to [~~insure~~] **ensure** that the base material is in general conformance with design grade and alignment and proper depth.
 - (3) Inspect to [~~insure~~] **ensure** that the base material is uniform and free of deleterious material and excess moisture.
 - (4) Inspect to [~~insure~~] **ensure** that compaction of base material is done in proper lifts as per the specifications and at the conclusion of compaction activity, insure that proper compaction has been done by verifying compaction test results from testing firm and by visual observation of 'pumping' or other deficiencies.
- (d) Paving Inspections—Minimum of one (1) inspection per paving operation by contractor plus one (1) additional inspection per five hundred (500) tons of asphalt placed per day.
- (1) Inspect to [~~insure~~] **ensure** that weather conditions are appropriate per specification requirements.
 - (2) Inspect to reconfirm that base material has not been damaged and has no excess moisture.
 - (3) Inspect to [~~insure~~] **ensure** that all appropriate and proper equipment (payers, rollers, etc.) is available and being used for the type of paving operation undertaken.
 - (4) Inspect to [~~insure~~] **ensure** that the tack coat material meets specifications and has been applied in accordance with the specifications.
 - (5) Inspect to [~~insure~~] **ensure** that the asphalt supplied to the job meets the project specifications prior to placing and is being delivered at the proper specification temperatures.
 - (6) Inspect to [~~insure~~] **ensure** that the asphalt is being placed at the proper minimum depths and that the finished surfaces properly adhere to meet lines and joints per the specifications.
 - (7) Inspect general operation, workmanship and quality of the contractor's crew.
 - (8) Inspect to [~~insure~~] **ensure** that the asphalt meets specifications by receiving testing results from testing firm and verifying compliance.
- (e) Utility Facility/Monument Adjustments—Minimum of one (1) inspection per item being adjusted to grade.

- (1) Inspect to [~~insure~~] **ensure** that asphalt removal around item being adjusted (valve cover, manhole, vault box, monument cover, etc.) leaves a sawcut or otherwise neat, clean vertical face for patching.
- (2) Inspect to insure that item being adjusted is set to grade as required by specifications (see sewer, storm drain and water final inspections).
- (3) Inspect to [~~insure~~] **ensure** that asphalt and/or concrete portions of permanent patch around item are placed in conformance with specifications.
- (f) Street/Traffic Control Sign Inspections—Minimum of one (1) inspection per sign installation.
 - (1) Inspect to [~~insure~~] **ensure** that sign foundation, sign post and sign materials all meet specifications.
 - (2) Inspect to [~~insure~~] **ensure** that signs are installed in locations per the approved plans and in conformance with specifications.

9. Pavement Surface Seal

- (a) General Inspections—Minimum of one (1) inspection per increment unit of work.
 - (1) Inspect to [~~insure~~] **ensure** that asphalt surface is clean and free of deleterious materials and moisture.
 - (2) Inspect to [~~insure~~] **ensure** that all utility facilities and monument covers are covered and protected from the seal coat operation.
- (b) Placement Inspections—Minimum of one (1) inspection per increment unit of work.
 - (1) [~~insure~~] **Ensure** that weather conditions are appropriate per specification requirements.
 - (2) Inspect to [~~insure~~] **ensure** that asphalt and any treatment material (sand, chips, etc.) meets all specifications.
 - (3) Inspect to [~~insure~~] **ensure** that distribution equipment meets specifications and that all materials are being placed in conformance with the specified distribution rates.
- (c) Striping and Pavement Marking Inspections—Minimum of one (1) inspection per increment of pavement being painted or marked.
 - (1) Upon completion of surface treatment with proper cure or after completion of paving if no surface treatment is required, inspect to [~~insure~~] **ensure** that pavement striping and markings are in conformance with project plans for layout and alignment.
 - (2) Inspect to [~~insure~~] **ensure** that pavement marking materials are in conformance with project specifications.

10. Miscellaneous Improvements

- (a) Slope Treatment Inspections—Minimum of one (1) inspection per increment unit or work.

- (1) Inspect to [~~insure~~] **ensure** that slope adheres to design plan for slope and grade.
 - (2) Inspect to [~~insure~~] **ensure** that slope treatment material is in conformance with specifications.
 - (3) Inspect to [~~insure~~] **ensure** that slope treatment material is placed in conformance with plans and specifications.
- (b) Retaining Wall Inspections—Minimum of one (1) inspection per retaining wall section.
Prior to performing inspections, determine if the building and safety department has issued a permit to construct the wall and that they are notified of any required inspections that they must perform.
- (1) Inspect to [~~insure~~] **ensure** that all excavations for wall installation adhere to plan grades and alignments.
 - (2) Inspect to [~~insure~~] **ensure** that base treatment for wall structure is properly placed in conformance with plan grades and alignments and specifications.
 - (3) Inspect to [~~insure~~] **ensure** that all wall materials are in conformance with specifications.
 - (4) Inspect to [~~insure~~] **ensure** that any forms and steel for a poured-in-place wall are installed in conformance with the plan design grades and alignment and meet all specifications.
 - (5) Inspect to [~~insure~~] **ensure** that wall is completed in conformance with plans and specifications.
 - (6) Inspect to [~~insure~~] **ensure** that all backfill is properly placed and compacted and that the entire wall work area has been cleaned and finished.

11. Survey Monumentation

- (a) Inspect to [~~insure~~] **ensure** that all monuments and lot corners are in place and that all monument covers are properly adjusted, accessible, and marked "survey."

12. Park and/or Landscaping Improvements. Prior to performing inspections, determine if a the building and safety department has issued a permit for electrical or irrigation backflow prevention and that they are notified of any required inspections that they must perform.

SECTION XXXX:

That Title 18 Appendix (CARSON CITY DEVELOPMENT STANDARDS), Division 21 (CONSTRUCTION OF IMPROVEMENTS INSPECTION & TESTING REQUIREMENT REPORTS), Section 21.5 (Partial release of security) is hereby amended (**bold, underlined** text is added, [~~stricken~~] text is deleted) as follows:

21.5 Partial release of security.

Upon installation of improvements and inspection approvals for each phase of construction, the subdivider may submit a "request for partial release of security" form to the engineering department. Release requests will be processed by the engineering department within five (5) working days. Releases will be approved at the following increments upon completion of the following:

- a. Grading—cut slope, drainage swales and channels, detention basins, inspected and passed, fills compaction tested and passed.
- b. Sewer mains and appurtenances—sewer mains and laterals have been pressure tested and passed, manholes have been vacuum tested and passed, and mains have been mandrel tested, televised, and passed.
- c. Storm drains and appurtenances—catch basins, drop inlets, head walls, culverts, manholes, inspected and passed.
- d. Water mains and appurtenances—water mains, laterals and fire hydrants inspected, pressure, chlorine and bacteria tested and passed. Valves accessible for operations.
- e. Reclaimed water mains and appurtenances—reclaimed water mains and laterals have been pressure tested and passed. Valves accessible for operations.
- f. Utility trench, bedding, conduits, backfill, vaults, boxes and pads inspected and passed by the utility companies.
- g. Curb/gutter and sidewalk and appurtenances—subgrade and base inspected, tested, and passed. Concrete cylinders tested and passed. Concrete finish work inspected and passed.
- h. Pavement and appurtenances—subgrade, base and asphalt inspected, tested and passed. Utilities adjustments, street and traffic control signing and devices and appurtenances inspected and passed.
- i. Pavement surface seal inspected, tested and passed or sufficient funds paid to Carson City.
- j. Miscellaneous improvements required as a condition of development approval, such as revegetation, landscaping, fencing, etc., inspected, tested, and passed.
- k. Survey monumentation—centerline monumentation and lot corners inspected and passed.
- l. Subdivider furnished park and/or landscape improvements inspected and passed.

Partial release will be made in the amount of the security for that phase of the completed portion, less ten percent (10%) of the cost estimate. Approval of a partial release will be prepared and authorized by the appropriate department. Phasing of increments may be allowed if original estimate reflects the phasing at the time the security is posted. (Resolution Number 1997-R-37)

SECTION XXXX:

That Title 18 Appendix (CARSON CITY DEVELOPMENT STANDARDS), Division 21 (CONSTRUCTION OF IMPROVEMENTS INSPECTION & TESTING REQUIREMENT REPORTS), Section 21.6 (Required inspection and testing) is hereby amended (**bold, underlined** text is added, [~~stricken~~] text is deleted) as follows:

21.6 Final inspection.

- a. Upon completion of all construction related to the above and prior to final acceptance, one (1) set each of record drawing prints prepared by an engineer or surveyor licensed in the state of Nevada shall be supplied by the owner/developer along with a written request for a final inspection to the engineering department inspector.
- b. The engineering inspector will schedule final inspections by all departments and compile written deficiency lists. The engineering inspector will schedule an [~~on-site~~] **onsite** meeting with the owner, contractor and all concerned departments within ten (10) working days of receipt of the request for final inspection to discuss deficiency list items. Projects which do not involve public water or sewer main extensions will be scheduled within five (5) working days.
- c. Upon completion of any deficiency list items, the owner/developer shall submit a written request to the engineering inspector for final inspection. The inspector will schedule inspections, and if all work is acceptable, provide the owner with a written approval and a request, mylar record drawings and a maintenance bond within ten (10) working days. Should all items on the original punch list be incomplete or additional damage to improvements which occurred after the inspection be discovered, the inspector will provide the owner and contractor a second deficiency list and subsequent inspections will be scheduled depending on [~~work load,~~] **workload**, which may exceed ten (10) working days.
- d. Upon completion of any deficiency list items addressed by the final inspection and receipt of reproducible record drawings by the engineering department, the city will provide written acceptance of the public improvements for maintenance purposes.
- e. Should the developer default on the time frames as established by the Carson City Municipal Code (CCMC), the city shall pursue the collection of monies due for completion of improvements. The city may assign a third party to complete said improvements in the designated time frames as established by CCMC. Any excess funds shall be refunded. (Resolution Number 1997-R-37)

SECTION XXXX:

That Title 18 Appendix (CARSON CITY DEVELOPMENT STANDARDS), Division 21 (CONSTRUCTION OF IMPROVEMENTS INSPECTION & TESTING REQUIREMENT REPORTS), Section 21.7 (Record drawings) is hereby amended (**bold, underlined** text is added, [~~stricken~~] text is deleted) as follows:

21.7 Record drawings.

- a. Record drawings submitted to the engineering department shall be accompanied by a transmittal letter which identifies the development by name, address, A.P.N., and the reason for the submittal.
- b. Reproducible record drawings [~~shall be three (3) mil (minimum) mylar.~~] **must be 1 electronic CAD file and 1 electronic PDF file.**
- c. Record drawings shall be prepared and signed by a Nevada licensed engineer or surveyor and shall include the following:
 1. Centerline stationing and dimensions from street centerline or easement line for all sewer manholes and lift stations.
 2. Centerline stationing and dimensions from street centerline or easement line for all water and reclaimed water valves, hydrants, meter boxes, flush valve assemblies, air release valves, check valves, booster pump stations and pressure reducing stations.
 3. Stationing and dimensions for all private fire hydrant and sprinkler line installations are required from the main to the check valves only.
 4. Centerline stationing and dimensions from street centerline or easement lines for catch basins, drop inlets, storm drain manholes, face of curb, sidewalk and/or edge of pavement.
 5. Operation and maintenance information and dimensions for all specialty items such as pressure reducing valve stations, water tanks, altitude valves, booster pump stations, and lift stations.
 6. Information received from the contractor and/or city inspectors.
 7. The engineer or surveyor shall prepare the record drawings on a copy of the plans approved and signed by Carson City. The changes shall be noted by marking a line through the dimension or elevation and noting the new dimension or elevation adjacent to it with an "A. B." designation (i.e., 22.5° 23.2' A.B.).
 8. The engineer or surveyor shall place a certification on the drawing stating that the record drawings accurately reflect items (1) through (7) above, to the best of their knowledge and belief.

SECTION XXXX:

That Title 18 Appendix (CARSON CITY DEVELOPMENT STANDARDS), Division 21 (CONSTRUCTION OF IMPROVEMENTS INSPECTION & TESTING REQUIREMENT REPORTS), Section 21.8 (Maintenance bond) is hereby amended (**bold, underlined** text is added, [~~stricken~~] text is deleted) as follows:

21.8 Maintenance bond.

A maintenance bond that fully complies with the provisions of the subdivision agreement, PUD agreement or parcel map agreement shall be submitted prior to final acceptance. (Resolution Number 1997-R-37)

SECTION XXXX:

That Title 18 Appendix (CARSON CITY DEVELOPMENT STANDARDS), Division 22 (STREET NAMING AND ADDRESS ASSIGNMENT REGULATION), Section 22.1 (Purpose) is hereby amended (**bold, underlined** text is added, [~~stricken~~] text is deleted) as follows:

22.1 Purpose.

These regulations have been prepared by the Carson City Fire Department in order to set forth the requirements for naming streets and assigning addresses within Carson City.

22.2 Definitions.

Access is a way or means by which a vehicle enters a lot or parcel or a person enters a building.

Address is a number, directional prefix, primary street name, and suffix. The property address is also called the site or general address.

Addressing official is the City Engineer or his designee who is charged with the administration of these standards.

Alignment is the continuation or adjournment of a street or streets.

Assessor's parcel number is a number assigned to a lot or parcel for tax assessment identification.

Baseline is a north-south or east-west line used as a zero starting point for address numbers.

Bubble street is a type of cul-de-sac which measures less than 100 feet from the point of radius of the turnaround to the centerline of the connecting street.

Block interval is a numerical grid by which each block is addressed.

Building is a structure designed for human occupancy or use.

Commercial development is a building constructed for commercial (profit making) purposes.

Cul-de-sac is a street ending in a dead-end, not being an extension of another street, having no other street intersections, and not having the capability of connecting or intersecting with another street in the future. A Cul-de-Sac is considered a "Bubble Street" if it meets the definitions for such a street.

Directory is an address information map or model located at an access point detailing building suite and/or unit location(s). See also "Monument Sign."

Floor - See Story.

General address - See Address.

Hundred block is an incremental number breakdown of a section of land. It has a hundred numbers, 0 through 99.

Hundred block indicator is a number and has either a direction prefix or prefix indicating the perpendicular distance of a street from its parallel baseline.

Legal address is the address that has been officially assigned by the City.

Major arterial is a street falling on a Township or Range line, a section line, a quarter section line, or another alignment that is 80 feet in width or greater, which is designed to accommodate through-traffic with comparatively long vehicle trip lengths.

Major division occurs in a nonresidential and/or mixed-use building(s) with a minimum of one structural/load bearing or 4-hour fire wall separating a minimum of two suites and/or buildings.

Master site address is an address assigned for the management of records and permits pertaining to the total development or complex.

Mixed-use is the vertical integration of residential uses and commercial or civic uses within a single building or a single development, where pedestrian access, vehicular access and/or parking functions for the uses are shared.

Monument sign is a sign placed in a conspicuous location to indicate the address range of a group of buildings when such building addresses are not readily visible from the main access street.

Municipal pertains to Carson City, but may also pertain to other government buildings.

Non-residential complex is a commercial or industrial development having three or more buildings.

Number is part of an address based on the numerical distance from an appropriate baseline. Numbers used for addressing purposes shall be whole numbers only.

Prefix is a directional identifier (North, South, East, West, etc.) that precedes the street name and is not a suffix. A prefix is also known as a directional prefix.

Person refers to any individual, firm, corporation, partnership or other legal entity or their authorized agent.

Plat is a scaled map of a town or a section of land that has been subdivided into lots showing the location and boundaries of the individual parcel with the streets, alleys, easements, and rights of use over the land of another.

Point-of-origin is the intersection of the north-south and east-west baselines establishing zero at the intersection. (See Figure 1)

Primary street name is the portion of a street name which is neither a directional prefix nor a suffix. Example: West Telegraph St., where "Telegraph" is the primary street name.

Residential development is a development intended for human habitation.

Residential complex is a development having three or more buildings.

Site plan is a map showing property boundaries with dimensional ties to section, township and range monuments, building locations, dimensions of property, buildings and setback distances to property lines, primary access points for property and buildings, dimensional ties of tenant improvements to a building shell, access from closest public street for non-subdivided parcels, with a north arrow.

Site is the address of a lot, parcel or building; also called the "property address".

Street is any public or private thoroughfare or easement reserved for vehicle travel and access unless the context requires a different meaning.

Street name is the primary street name and suffix. It shall not include the directional prefix.

Street sign displays the primary name, suffix, direction from a baseline and the north, south, east or west hundred block indicator of each street name.

Story is the vertical distance from top to top of two successive finished floor surfaces; and for the topmost story, from the floor finish to the top of the ceiling joists or, where there is not a ceiling, to the top of the roof rafters.

Suite number - See unit number for definition.

Structure is any fence, tower, edifice, or building of any kind, or any piece of work artificially built up or composed of parts joined together in some temporary or definite manner which requires location on the ground or is attached to something having a location on the ground which extends more than 36 inches above grade.

Suffix is a word in a street name used to indicate a type of street. That portion of a street name which indicates that it is a right-of-way, such as "Street," "Avenue," "Lane," "Road," "Circle," "Way," etc.

Tenant improvement is an improved space within a building, which is under separate control, has primary access to exterior or interior public spaces, and is used for residential or nonresidential activity.

Unit address is a specific number delineating individual unit locations within a single site. A unit address may share a common entrance, so long as there is a dividing wall and separate business licenses in the case of a commercial or industrial use.

22.3 Standard Addressing Regulations.

22.3.1 Address Assignments.

- a. All addresses shall be assigned by the Addressing Official or designee.
- b. All addresses are to be unique and will not be duplicated.
- c. Addresses shall be assigned in such a way that each separate building will be assigned a unique address number.
 - (1) Buildings with multiple occupancies will be assigned suite numbers in accordance with the regulations in this document.

- (2) Buildings with major divisions may be assigned unique address numbers.
- (3) Building addresses shall be assigned to the primary street from which the major ingress and egress occurs.
- d. It shall be the property owners' and/or the developer's responsibility to obtain a legal address for new development.
- e. All local utility companies shall receive proof of a legal address prior to any utility service being connected. (See Section 22.8.6).

22.3.2 Address Numbering.

- a. An address shall be assigned within the appropriate addressing range in accordance with the provisions of this document.
- b. The number assigned shall be within the address range available within the appropriate hundred block.
- c. Address assignments shall be maintained on street address maps maintained in the Assessor's Office as well as in the office of the Addressing Official.
- d. For the purpose of address assignment, curved streets shall be treated as if they were straight.
- e. All addresses on the east and south side of a street shall be given an odd number except on a looped street.
- f. All addresses on the west and north sides of a street shall be given an even number except on a looped street.
- g. A looped street shall be addressed from the appropriate hundred block of the primary direction of the loop.
 - (1) Addresses shall be assigned starting at the entrance of a looped street and continue counterclockwise around the outside with even numbers to the outside and odd numbers to the inside of the loop.

22.3.3 Address Changes and Vested Rights.

- a. Street names and/or address numbers may be changed or altered, depending upon need as determined by the Addressing Official. Streets that have had any structures erected upon them, must have Board of Supervisor approval prior to any changes being made.
- b. When there is knowledge of an incorrect address, and/or a duplicate street name and/or address, the affected property owners shall be promptly notified that a change of street name and/or address number may occur. Property owners do not have vested rights to street names and/or address numbers, even if a street name and/or address has been used for many years.
- c. If a change or correction is deemed necessary by the Addressing Official the procedure shall be as follows:
 - (1) The Assessor's Office shall correct the address on the street address maps, charts and/or automated mapping system.

- (2) The affected property owners will receive notice of the new street name or address number.
- (3) The City shall notify the affected government agencies and utility companies that a change has occurred.
- d. Any property owners of residential or non-residential structures affected by the provisions of this subsection shall, upon proper notice, bring such structures into conformance with this Ordinance within six months.
- e. If the affected property owners or their designated representatives perceive that an address was unreasonably changed, then the affected property owners or their designated representatives may file an appeal to the Addressing Official within 30 days from the date that proper notification was sent.
- f. The decision of the Addressing Official may be appealed to The Board of Supervisors.

22.4 Street Naming Guidelines.

22.4.1 Use of Street Names.

- a. A primary street name shall be used only once and shall not be used in any other alignment. The same primary street name cannot be repeated with a different suffix nor may a name be separated and used again (e.g. Bitterroot St. - Bitter Root St.).
- b. Once a primary street name is assigned to any alignment it shall not change anywhere along the extension of that alignment unless the subject primary street name does not and cannot in the future connect to the existing public right-of-way.
- c. Names that are the same or pronounced the same (homonyms) or similarly with different spellings may be used only once, e.g., Ellis: Alice, Allen: Alan, Hinson: Henson.
- d. Only the common or correct spelling of street names will be accepted. E.g. Jane not Jayne, or Frederick not Phrederyck.
- e. Street names in a foreign language will not be considered unless accompanied by a common English translation and their meaning is inoffensive and/or reasonable.
- f. Foreign language suffixes (e.g. Via, Camino, Rua, Chemin, Rue, etc.) shall not be used in any part of a street.
- g. Names that tend to be slurred or difficult to pronounce by emergency response services shall not be used.
- h. Street names are restricted to a maximum of 20 characters (includes street name, space, prefix, and suffix).
- i. Directional prefixes and suffixes are not permitted as primary street names (e.g. Northgate Rd.).
- j. No street names can be a stand-alone preposition, conjunction, numbers or letters.
- k. Driveways shall not be named.

1. The Carson City Board of Supervisors may waive these street naming provisions as they deem necessary to accommodate special circumstances.

22.4.2 Use of Suffixes.

- a. "Avenue" shall represent any right of way lying in an east-west direction, not ending in a cul-de-sac and with sidewalk improvements.
- b. "Boulevard" or "Parkway" shall represent streets ranging from 80 feet to 120 feet wide with at least a portion of the street being separated by a planter or median.
- c. "Circle" or "Loop" shall represent a street starting and ending on the same street or itself, e. g., a horseshoe shaped street.
- d. "Court" shall represent a cul-de-sac with no side streets.
- e. "Drive" shall represent any right of way lying in a northeast-southwest direction, not ending in a cul-de-sac and with sidewalk improvements.
- f. "Highway" shall represent a road with a minimum of a 150-foot wide right-of-way, have controlled access, and a high-speed road with grade separation at interchanges.
- g. "Lane" shall represent any right of way lying in a north-south direction, not ending in a cul-de-sac and in a rural section of the City or any area without sidewalk improvements.
- h. "Place" shall represent any right of way that makes multiple directional changes which make other designations inappropriate.
- i. "Road" shall represent any right of way lying in an east-west direction, not ending in a cul-de-sac and in a rural section of the City or any area without sidewalk improvements.
- j. "Street" shall represent any right of way lying in a north-south direction, not ending in a cul-de-sac and with sidewalk improvements.
- k. "Trail" shall represent a meandering road in a rural mountainous area.
- l. "Walk" shall represent a non-motorized path or track made across a wild region or rough country for the passage of humans or animals.
- m. "Way" shall represent any right of way lying in a northwest-southeast direction, not ending in a cul-de-sac and with sidewalk improvements.

22.5 Configuration for Street Naming.

22.5.1 Offset Street Alignments.

- a. When a street changes its alignment at an intersection by a distance equal to or less than two times the width of the right-of-way, it shall retain the name of the original alignment to provide traffic and addressing continuity. See Figure 2A.
- b. When a street changes its alignment at an intersection by a distance greater than two times the width of the right-of-way, it shall be assigned a new street name. See Figure 2A.

- c. Curvilinear streets shall maintain the same street name. See Figure 2B.
- d. When a street shifts its alignment (north/south on an east/west alignment or east/ west on a north/south alignment), it shall be assigned a new street name. See Figure 2C.

22.5.2 Straight Streets.

- a. A newly developed street shall assume the name of the street with which it aligns if such alignment exists. See Figure 3A.
- b. When a street is not in alignment with, nor an extension of any existing street, a new street name shall be assigned to the street. See Figure 3B.
- c. Once a street name is assigned to an alignment, it may not be assigned to any other alignment or be assigned if it will not connect in the future. See Figure 3C.

22.5.3 Cul-de-sac and Bubble Streets.

- a. When a cul-de-sac is located at the end of an existing street right-of-way or alignment, it shall be given the same primary name and suffix of that street, whether the cul-de-sac is straight, curves or meanders. See Figure 4A.
- b. When cul-de-sacs are located in such a manner as to be connected to each other by a straight or arcing street which is more or less perpendicular to an adjoining street alignment forming a "T" intersection, said cul-de-sacs and the connecting street shall be given the same primary street name, which must be a different name than the street it connects to. See Figure 4B.
- c. When cul-de-sacs approach each other from opposite directions and are on the same alignment but do not join in any manner, they shall be assigned different street names. See Figure 4C.
- d. When two cul-de-sacs are in direct alignment, bisected perpendicularly by a street, the cul-de-sac shall be assigned the same street name. See Figure 4D.
- e. When a bubble street less than 100 feet in length is located perpendicular to the primary street, the bubble street shall assume the primary name and address numbering of the street which it adjoins. See Figure 4E.

22.5.4 Circle, Horseshoe, and Loop Streets.

- a. A circular or horseshoe shaped street shall not be assigned the same primary street name as that of the principal street it intersects. See Figure 5A.
- b. A circular or horseshoe shaped street may carry the same primary street name throughout, or a new primary street name may occur at natural breaking points such as intersections and knuckles. See Figure 5A and 5B.
- c. In the case of loop streets having only one access, each segment of the loop will bear the same primary street name. See Figure 5C.
- d. When circular streets are segmented into halves or quarters by intersecting streets, the following shall apply:
 - (1) No two streets terminating on the same circle shall have the same name. See Figure 6A.

- (2) If the intersecting streets maintain the same primary street name on both sides of the intersected circle and buildings are to be built along the circular street, then each resulting segment of the circular street shall be assigned a different street name. See Figure 6B.
- (3) If the intersecting streets maintain the same primary street name on both sides of the intersected circle and no buildings are to be built along the circular street, then the circular street may maintain the same primary street name. See Figure 6C.

22.5.5 Curvilinear Streets.

- a. A street which leaves its alignment by not more than 150 feet may retain the name of the original alignment. See Figure 7A.
- b. A street which leaves its alignment by more than 150 feet but returns to its original section alignment, shall use the primary street name of the original alignment. See Figure 7B.
- c. A curvilinear street which changes direction but doesn't terminate at an intersection may maintain its primary street name throughout. See Figure 7C.

22.6 Address Assignments for Manufactured Home Parks and Residential and Non-Residential Complexes.

22.6.1 Multi-Family Residential Addressing. (See Figure 8)

- a. All multi-family residential developments shall be assigned an address (street number, direction, street name) corresponding to the appropriate hundred block. The development address shall be called the "Master Site Address." The Master Site Address shall be used for all common areas and may also serve as the address of the office/clubhouse etc., provided it is a standalone building.
- b. All individual buildings within the development shall be assigned an address corresponding to the appropriate hundred block.
- c. All units of all buildings shall be provided with a unique unit number.
 - (1) If single story, the units shall be numbered in numeric sequence, beginning with number one and continuing in a counterclockwise direction from the primary entrance.
 - (2) If multi-story, with less than 100 total units per story for the entire development, a three digit number shall be assigned to each unit starting at the primary entrance and continuing counterclockwise as follows:
 - B100—B199 for the first level below grade
 - 100—199 for first floor units
 - 200—299 for second floor units
 - 300—399 for third floor units, etc.

NOTE: The corresponding unit numbers shall "line-up", one above/below the other when possible.

- (3) If multi-story, with more than 100 or more total units per story for the entire development, four digit numbers shall be assigned to each unit starting at the primary entrance and continuing counterclockwise as follows:

1000—B1099 for the first level below grade

1000—1999 for the first floor units

2000—2999 for the second floor units

3000—3999 for the third units, etc.

NOTE: The corresponding unit numbers shall "line-up", one above/below the other when possible.

- (4) Projects which are large or complex enough to create address requirements that cannot conform to the unit addressing system shall have addresses assigned on a case-by-case basis while holding to as many established standards as possible.

22.6.2 Manufactured Home Parks. (See Figure 9)

- a. A Master Site Address shall be assigned to the primary dedicated street from which the major ingress and egress occurs. The Master Site Address shall be assigned in accordance with the appropriate street name, number and direction of appropriate hundred block range. The Master Site Address shall be used for all common areas and may also serve as the address of the office/clubhouse etc., provided it is a standalone building.
- b. Each street within the park will be assigned a unique street name that conforms to these standards.
- c. Individual space numbers will be assigned addresses corresponding to the appropriate hundred block and in conformance with these standards.

22.6.3 Non-Residential/Mixed-Use Addressing. (See Figure 10)

- a. All separate and distinct non-residential and mixed-use developments having multiple tenant accommodations shall be assigned an address for each development corresponding to the appropriate hundred block. This address shall be called the "Master Site Address". The Master Site Address shall be used for all common areas.
- b. All individual buildings and/or major divisions within a development shall have an address assigned to the appropriate hundred block. The addition of any other buildings to the development shall require separate building addresses.
- c. The building address shall be assigned to the primary street from which the major ingress and egress occurs. Suite numbers shall start at a minimum of 100 if less than 100 suites per floor or 1000 if there are more than 100 suites per floor. When possible, suite numbers shall increase by increments of 10. If suite assignments in increments of ten are not feasible then use increments of five. In the case of a development that includes one or more private drives, or on corner lots with a secondary entrance and if all address numbers within the address range for primary access street have been assigned, then addresses shall be assigned, in accordance with Section 22.4, to the public street or private drive which is named in accordance with these regulations.

- d. All units or suites within any building or major division shall be assigned a unique number which represents the level or story of each unit. The first digit, or in the case of an underground unit the first two digits, of a suite shall represent the floor on which the suite is situated. On multi-story buildings, unit numbers shall line up with the unit above and below it. Most in-line retail and warehouse buildings are single story and have less than 100 suites. The address shall be referred to as the "Suite or Unit Address". It shall not be acceptable to use an alphabetic suffix for unit or suite addresses except for the letter B. The letter B shall be used to indicate below grade units (i.e. basement level).

- (1) Basement-level addressing shall be assigned in the following manner.

B100—B199 for the first underground level

B200—B299 for the second underground level

B300—B399 for the third underground level, etc.

1000—1999 for the first floor units

2000—2999 for the second floor units

3000—3999 for the third units, etc.

NOTE: The corresponding unit numbers shall "line up" with one above/below when possible.

22.6.4 Monument/Directional Signs.

- a. The City may require the placement of monument/directional signs on development sites where buildings and/or parking placement is obscure from the primary street the building is addressed. Directional signs shall conform to applicable sign regulations.
- b. Display requirements.
 - (1) If required, a directional sign shall be placed at each primary entry to the obscured building.
 - (2) If required, each directional sign shall carry the appropriate addresses or range of addresses and a directional arrow or location instructions as minimal direction information.
 - (3) During new construction, the assigned address for all residential and commercial development shall be displayed and will be setback 10 feet from the front property line adjacent to the primary entrance. This display shall contain both the street name and assigned addresses.

22.7 Address Display Requirements.

22.7.1 Size and Placement (See Figures 11 through 14 for illustrations/additional requirements).

- a. Single family and two-family residential properties shall attach addresses numbers a minimum of three inches in height. Individual apartment numbers and unit or suite

numbers shall also be three inches in height. Accessory structures (i.e. sheds, garages, and similar structures) shall be exempted from this requirement.

- b. All structures (except those described in 1 above) shall have address numbers five inches in height. Individual Unit or Suite numbers must be a minimum of three inches in height.
- c. All address numbers for any structure shall be conspicuously displayed in a contrasting color with the background of the structure.
- d. All address numbers for any structure must be clearly visible from the street or private drive to which each building and/or structure is oriented.
- e. Address numbers that are not visible from the public street or roadway may require the addition of a monument sign, to be erected at the entrance that will display the address or range of addresses.
- f. General address displays or signs for residential and non-residential complexes shall be in accordance with applicable state and municipal sign regulations.
- g. Manufactured Home Parks shall have a free-standing sign or monument sign with the general/master site.
- h. The placement of building numbers for residential and non-residential complexes shall be clear of all visual obstacles such as awnings, trees, covered parking areas or similar sight obstructions.
- i. Unit address numbers for residential and non-residential complexes shall be placed near or on the front door.
- j. Final approval of any building or unit/suite may be withheld until all required street address numbers have been permanently displayed and a Certificate of Occupancy has been issued.

22.7.2 Street Sign Requirements.

- a. Developers shall be responsible for providing and installing street signs in accordance with applicable municipal requirements.
- b. Directional signs shall have numbers of not less than six inches in height in accordance with the municipal sign requirements.
- c. All street signs, including illuminated street signs, shall contain the appropriate hundred block range. In the case of cul-de-sacs, the address range shall be identified.

22.7.3 Identification Directory.

- a. Non-residential and residential complexes may be required to display a permanent Identification Directory reflecting a scaled replica of the site in accordance with NFPA 1, Section 10.13 and the provisions of this document.
- b. The directory shall be located on the right side of any entrance driveway, not more than 100 feet from the entrance, but not beyond any diverging drives.

- c. The Identification Directory shall indicate the locations of all buildings, amenities, structures and fire hydrants in relation to all streets, driveways and sidewalks located within the complex.
- d. The Identification Directory shall be of adequate size so that letters, numbers and similar attributes are easily identifiable. In addition, all directories are to be illuminated at night.
- e. The property owner and/or developer shall submit five 8.5 inch x 11 inch copies of the site plan showing all applicable information to the Fire Department for approval prior to construction of the Identification Directory.

22.8 New Development.

22.8.1 Tentative Map Review.

- a. All proposed street names must be submitted by the developer on a separate alphabetical listing and be indicated on the Tentative Map.
- b. Street names will be checked for acceptability by the Addressing Official to ensure compliance with this document.
- c. The proposed street names shall be reserved as long as a Tentative Map has not expired.

22.8.2 Final Map Review.

- a. Street names are to be confirmed and are to be placed on the Final Map, including all private street names.
- b. The developer must specify any unusual addressing requirements. Street addresses shall not be issued until recordation of the plat.

22.8.3 Post-Recording Procedure.

- a. The property owner and/or developer shall furnish copies of the recorded plats to the appropriate government entities.
- b. A master subdivision/site address shall be assigned to all subdivisions. This address shall be unique and will not be duplicated.
- c. Address numbers shall be assigned by the Addressing Official on a copy of the recorded plat and provided to the developer.
- d. When the Street Address Maps are updated, the Addressing Official will prepare and send new address updates to all related utility companies and government entities.
- e. New street names and address ranges will be entered into a street directory that will be maintained by the Addressing Official.

22.8.4 Non-Subdivision Developments.

- a. Address numbers will be assigned through the building permit review process in accordance with these regulations.

OFFSET ALIGNMENTS

Figure #2

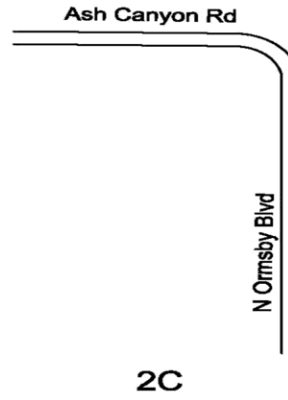
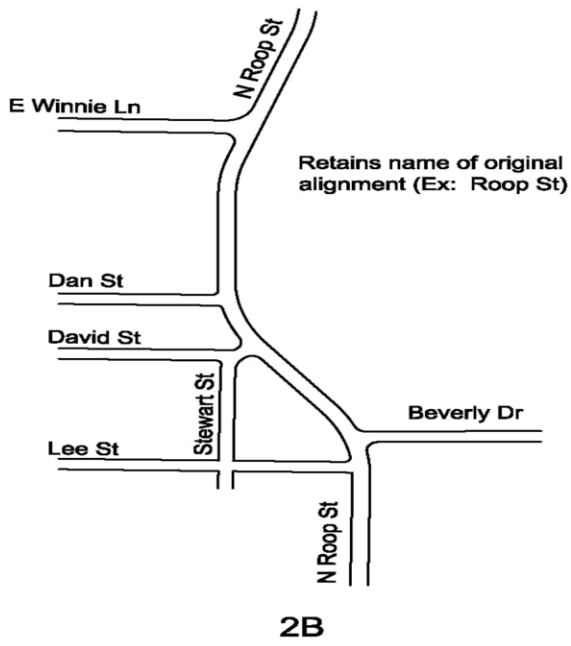
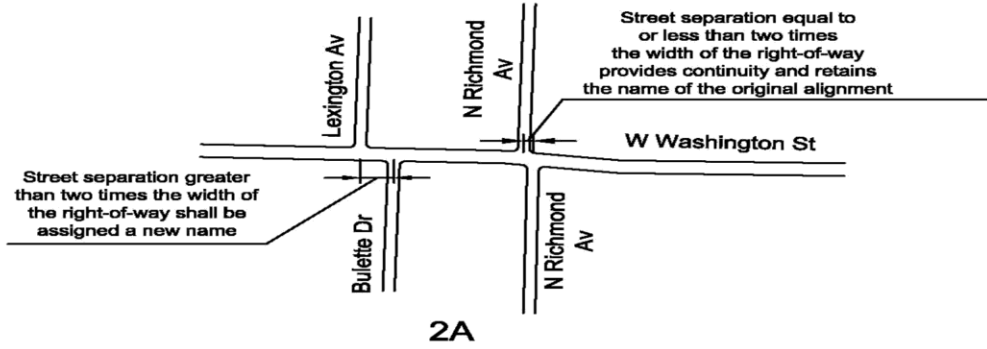

STRAIGHT STREETS

Figure #3

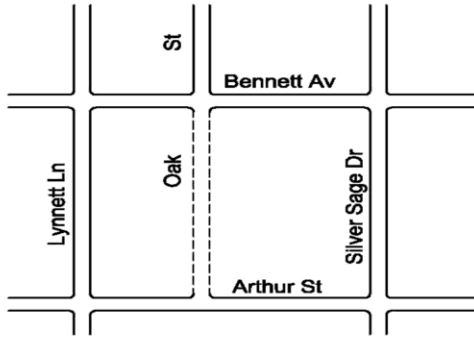

Assume the name of the street it is aligned with and connects with in the future.

3A

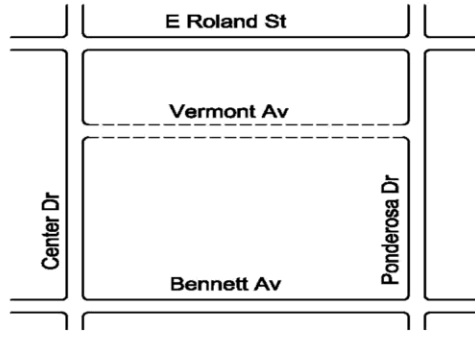

Not in alignment with, nor an extension of any other street.

3B

Proposed Streets	-----
Existing Streets	_____

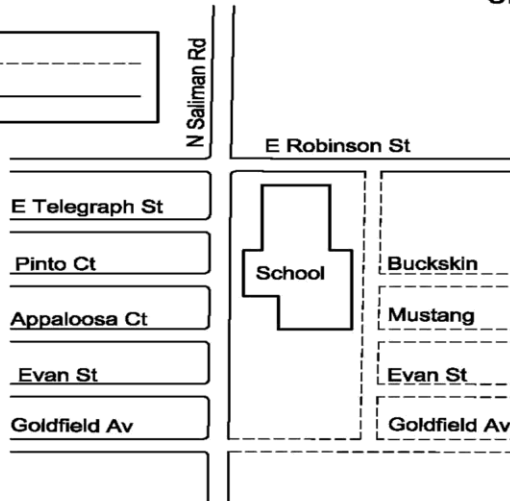

Existing street name cannot be assigned to a different alignment or be assigned if it will not connect in the future.

3C

CUL-DE-SACS & BUBBLES

Figure #4

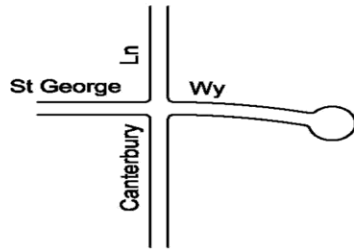

4A

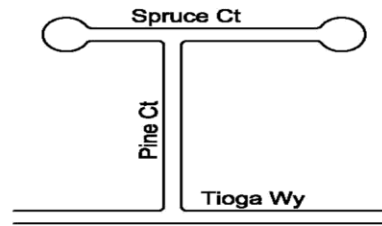

4B

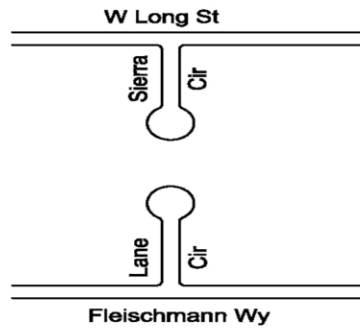

4C

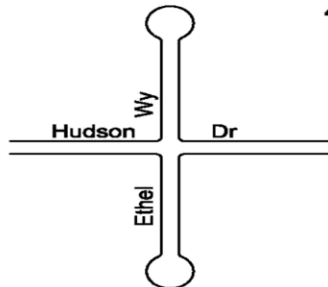

Connecting cul-de-sacs to have one name

4D

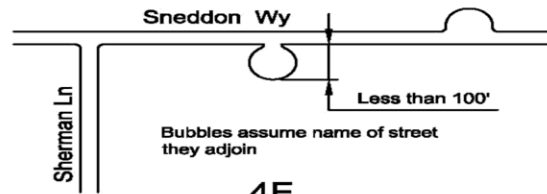

Bubbles assume name of street they adjoin

4E

HORSESHOES & LOOPS

Figure #5

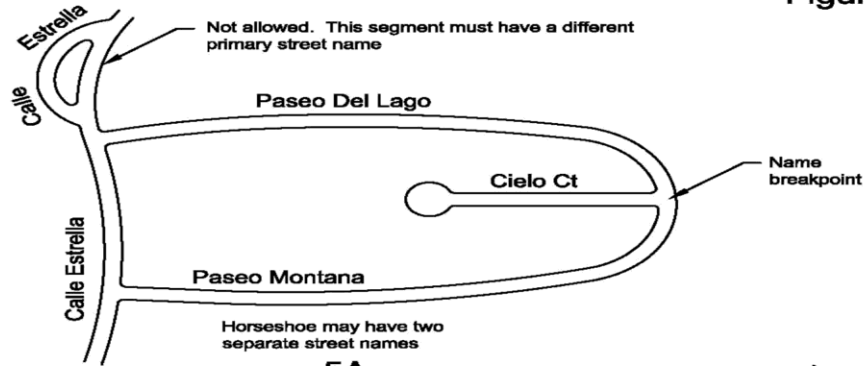

5A

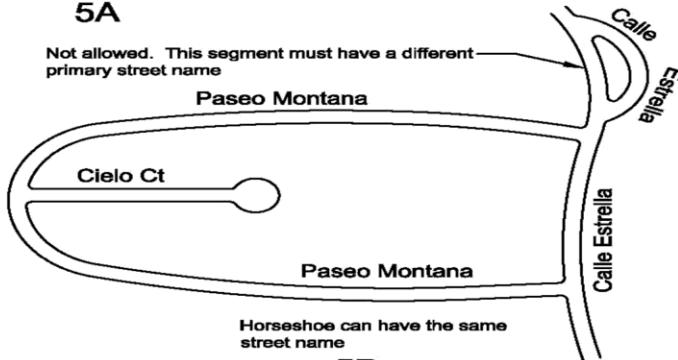

5B

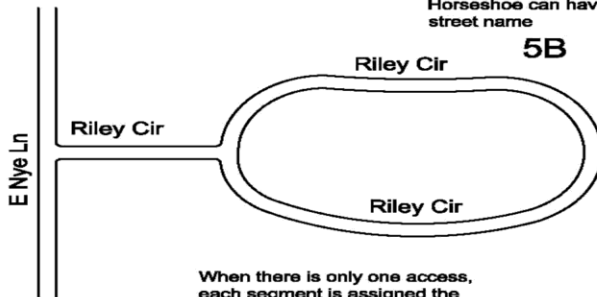

5C

CIRCLES & LOOPS

Figure #6

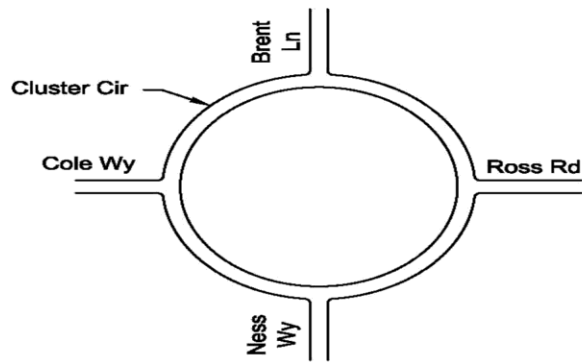

Circular or horseshoe-shaped streets shall not have the same street name as that of the principal street it intersects

6A

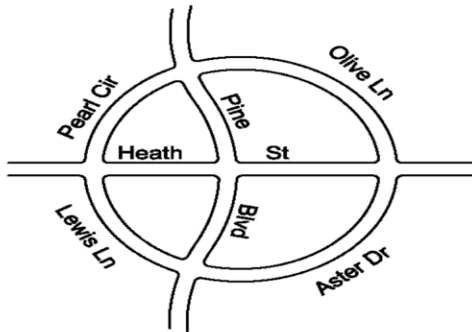

When buildings are on looped roads, street name changes at breaking points

6B

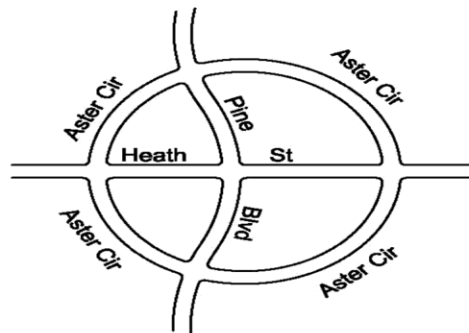

When no buildings are on looped roads, street name remains the same

6C

CURVILINEAR STREETS

Figure #7

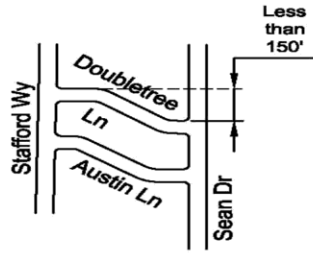

If the alignment is less than 150 feet the name remains the same

7A

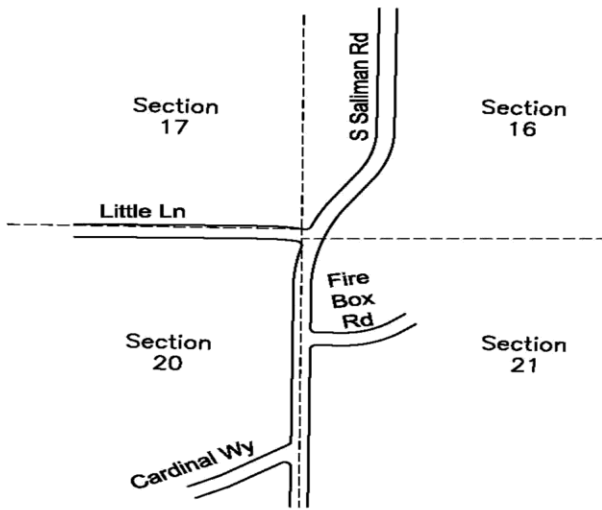

If street returns to section alignment the street name remains the same

7B

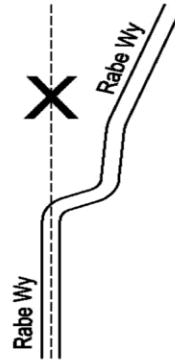

Original alignments cannot be extended

7C

MULTI-FLOOR RESIDENTIAL ADDRESSING SYSTEM

Figure #8

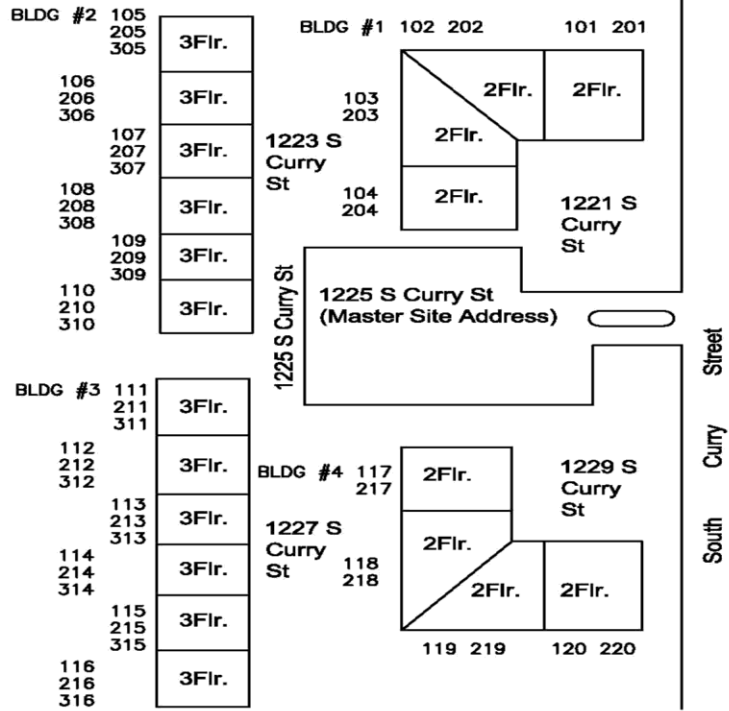

MANUFACTURED HOME PARK ADDRESSING SYSTEM

Figure #9

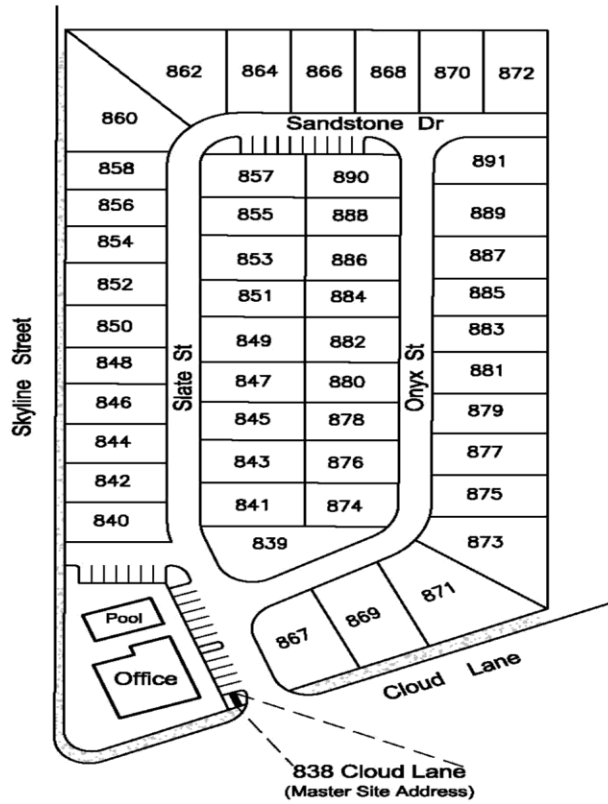

Manufactured Home Park receives one master address. Lots/space numbers are assigned from the primary entrance in a counter clockwise sequence starting from left to right. The office/club house receives the same address as the master site address.

SINGLE AND MULTI-FLOOR COMMERCIAL ADDRESSING SYSTEM

Figure #10

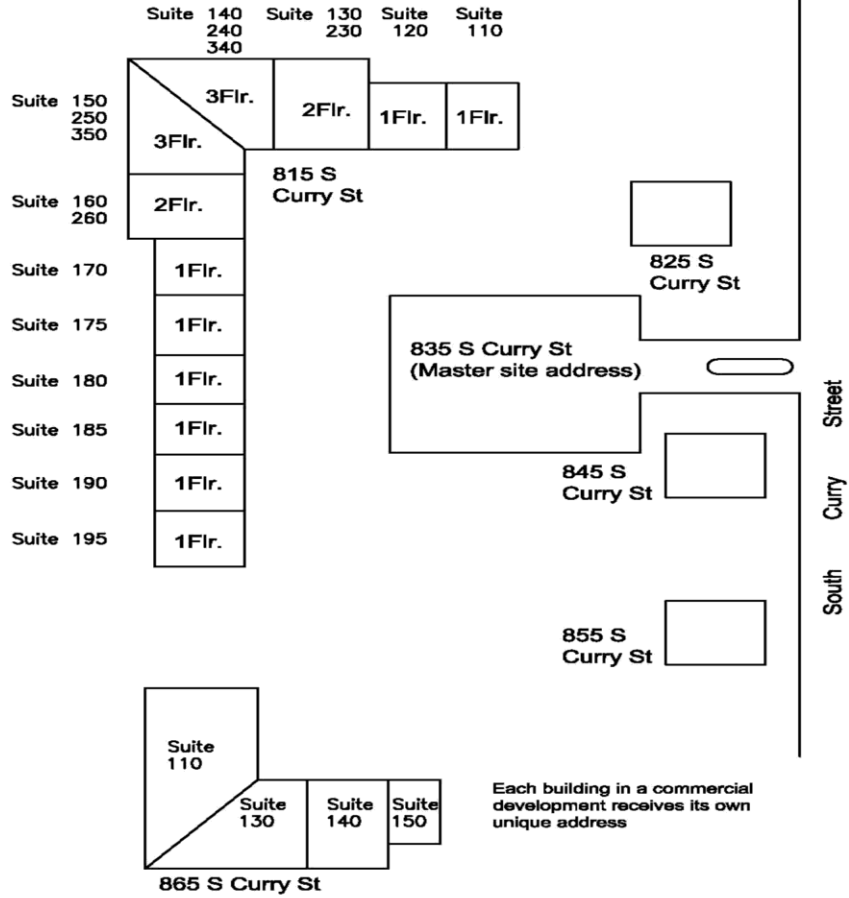

ADDRESSING DISPLAY REQUIREMENTS FOR SINGLE FAMILY RESIDENTIAL

Figure #11

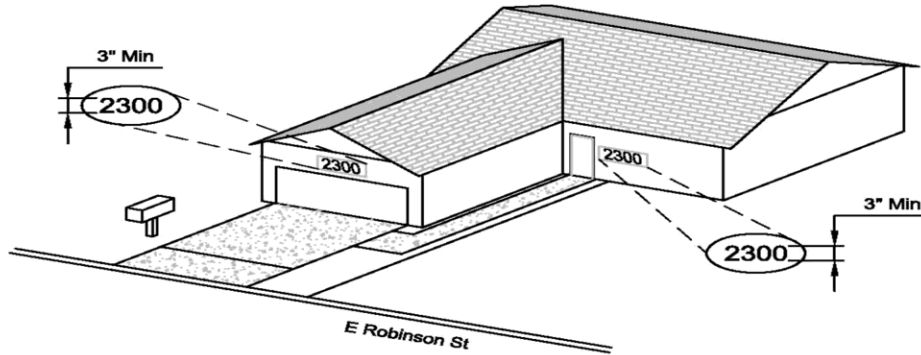

Requirements:

- Place address so it is visible from the street in both directions
- Contrast the color of the address numbers from the address background
- Illuminate the address directly or indirectly so it is visible at night
- Place address clear of landscape and visual obstructions

ADDRESSING DISPLAY REQUIREMENTS FOR COMMERCIAL COMPLEXES

Figure #12

Building address display requires a minimum 5 inch high numbers

Suite number must be at each entrance with a minimum of 3 inch high numbers (including rear entrances)

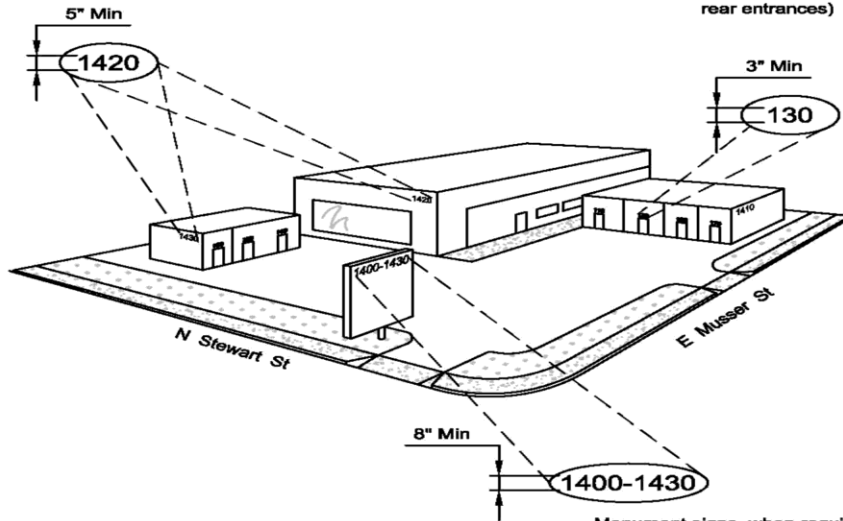

Monument signs, when required, must have a minimum address size of 8 inches and include the address range for all buildings in the complex.

Requirements:

- Address range must be displayed on the freestanding sign, if there is one on the lot
- Place address so it is visible from the street in both directions
- Contrast the color of address and suite numbers with the color of the background
- Illuminate the address and unit numbers directly or indirectly so they are visible at night
- Place address and unit numbers clear of landscaping and visual obstructions
- Suite address displays must be at every entrance

ADDRESSING DISPLAY REQUIREMENTS FOR MIXED USE & MULTI-FAMILY COMPLEXES

Figure #13

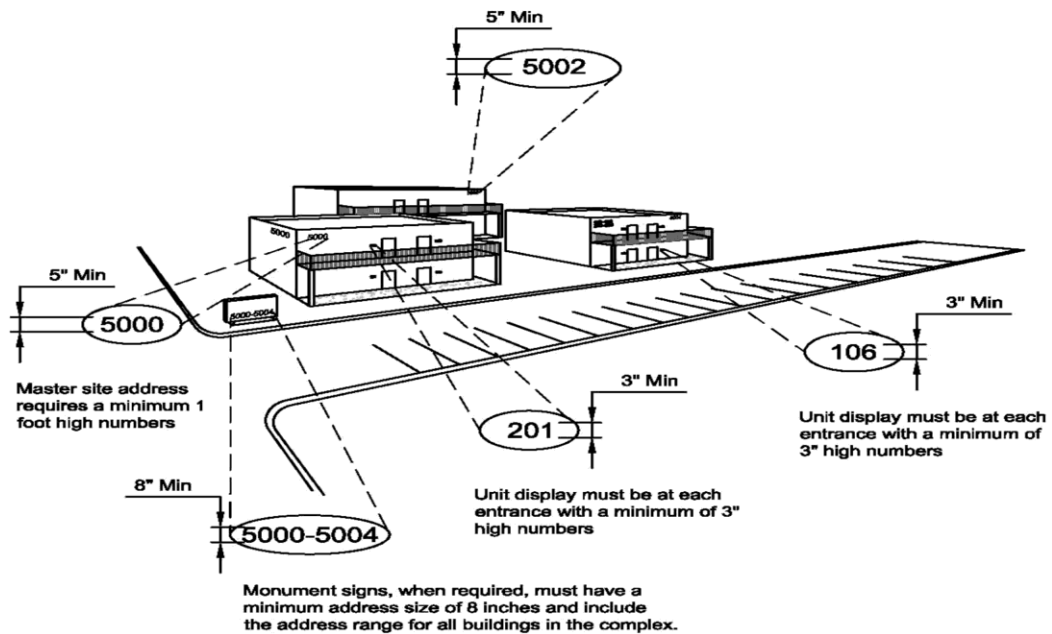

Requirements:

- Address range must be displayed on the freestanding sign, if there is one on the lot
- Contrast the color of address and unit numbers with the color of the background
- Illuminate the address and unit numbers directly or indirectly so they are visible at night
- Place address and unit numbers clear of landscaping and visual obstructions
- Unit address displays must be at every entrance

MANUFACTURED HOME PARK ADDRESSING DISPLAY REQUIREMENTS

Figure #14

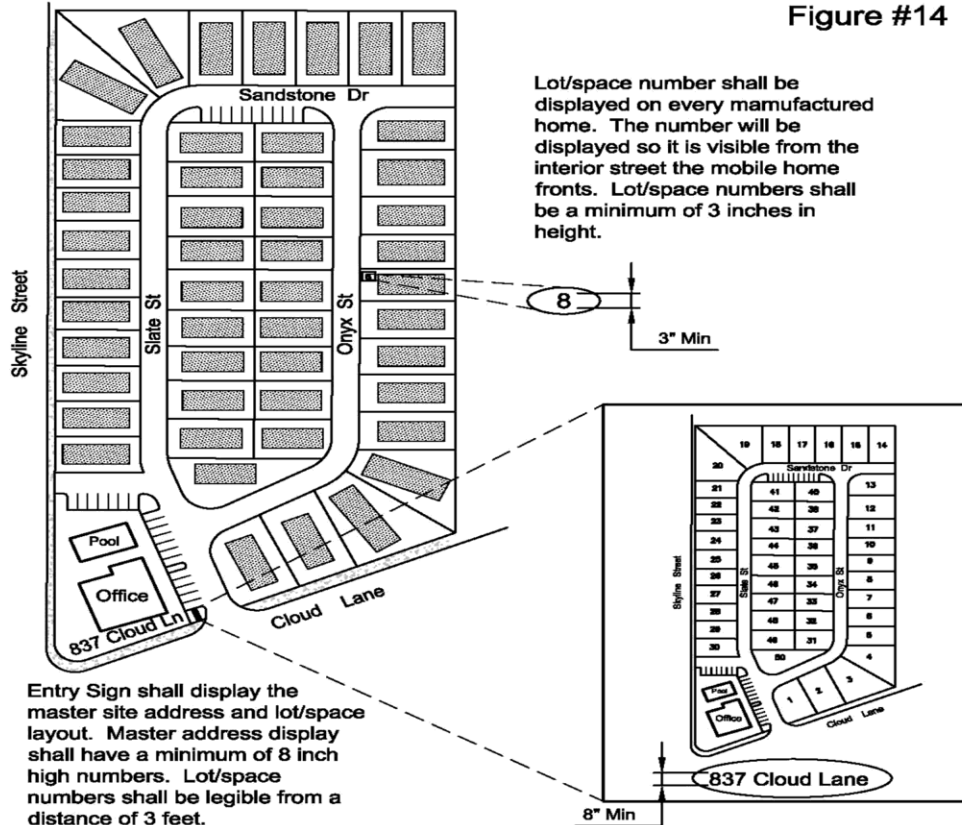

Lot/space number shall be displayed on every manufactured home. The number will be displayed so it is visible from the interior street the mobile home fronts. Lot/space numbers shall be a minimum of 3 inches in height.

Entry Sign shall display the master site address and lot/space layout. Master address display shall have a minimum of 8 inch high numbers. Lot/space numbers shall be legible from a distance of 3 feet.

Manufactured Home Parks receive one master address: Lot/space numbers are assigned from the primary entrance in a counter clockwise sequence. Each street within the park shall have its own name. When there is a single office/clubhouse then that structure receives the same address as the master site address. When there is more than one office/clubhouse then the office at the primary entry receives the master site address and all remaining offices receive an address within the proper street address range of the main entry.